



**Contracting Branch | Infrastructure Division
4200 Smith School Road
Austin, Texas 78744**

INVITATION FOR BIDS AND CONTRACT DOCUMENTS

**PROJECT NO. CR11387R
DANZ CABINS REPAIRS AT LYNDON B. JOHNSON STATE PARK AND
HISTORIC SITE
GILLESPIE COUNTY, TEXAS**

<i>IFB Issue Date:</i>	<i>January 24, 2024</i>
<i>Non-Mandatory Pre-Bid Meeting:</i>	<i>3:00 PM, February 05, 2024</i>
<i>Mandatory Site Visit</i>	<i>2:00 PM, February 06, 2024</i>
<i>Questions Due:</i>	<i>5:00 PM, February 12, 2024</i>
<i>Question/Answers Addendum</i>	<i>(Est) February 16, 2024</i>
<i>Bid Due Date:</i>	<i>2:00 PM, February 27, 2024</i>
<i>Virtual Bid Opening (TEAMS)</i>	<i>3:00 PM, February 27, 2024</i>

Contract Manager: Misty K. Wyatt, CTCD, CTCM
Email: misty.wyatt@tpwd.texas.gov

TABLE OF CONTENTS

GENERAL INFORMATION:

No. of Pages:

Title Page..... 1
Table of Contents..... 1
Notice to Bidders 3
Instructions to Bidders 4

CONTRACTOR'S BID SUBMITTALS:

Bidder Affirmations 5
Contractor's Qualification Statement..... 10
HUB Subcontracting Plan and Policy Compliance 9

CONDITIONS OF THE CONTRACT:

Uniform General Conditions (Including Supplementary Conditions) 70
Prevailing Wage Rates 6
Agreement between Owner and Contractor 5
Performance Bond 1
Payment Bond..... 1
Contractor's Progress Payment Affidavit 1
Contractor's Final Payment Affidavit..... 1
Consent of Surety to Final Payment 1
Non-Use of Asbestos Containing Materials Affidavit – Contractor 1
Remote Virtual Inspection Agreement 2

CONSTRUCTION DOCUMENTS:

DIVISION ONE – GENERAL REQUIREMENTS

Section 01000 – Special Conditions 12

SPECIFICATIONS: Refer to Table of Contents in Technical Specifications

DRAWINGS: 10 Sheets

EXHIBITS TO THE CONTRACT:

Exhibit A – HUB Subcontracting Opportunities (Form PWD 0991)
& List of HUB certified vendors by State Class & Item Code..... 40

TEXAS PARKS AND WILDLIFE

NOTICE TO BIDDERS

Danz Cabins Repairs at LBJ State Park and Historic Site
CR11387R

Sealed bids for the above project will only be accepted from Contractors when submitted to the Texas Parks and Wildlife Department using the online Bid Portal hosted by eBuilder. Bids will be accepted by the Contracting Branch, Infrastructure Division until 2:00 PM, February 27, 2024.

A virtual public bid opening of responses will be conducted by the Texas Parks and Wildlife Department via Microsoft Teams at 3:00 PM on February 27, 2024. Interested attendees must register in advance for this meeting. Click on the link below to register for the bid opening. After registering, participants will receive a confirmation email containing information about joining the meeting.

Bid Submittal Instructions:

1. Prepare your submission materials:

Requested Information

Name	Type	# of Files	Requirement
Bidder Affirmations	File Type: PDF (.pdf)	Multiple	Required
Contractor's Qualifications Statement	File Type: PDF (.pdf)	Multiple	Required
HUB Subcontracting Plan	File Type: PDF (.pdf)	Multiple	Required
Bid Security (scanned copy)	File Type: PDF (.pdf)	Multiple	Required

Please note the type and number of files allowed. Please do not embed any documents within your uploaded files as they will not be accessible or evaluated.

2. Upload your submission. Use the link below to access the Bid Portal.

- Bid Portal Link: <https://gateway.gov.e-builder.net/app/bidders/landing?accountid=121b7321-f922-472a-a736-897455b50fee&projectid=fb409fdb-e8f7-45ba-ae3b-73df755a7450&bidpackageid=33059448-a551-4b14-b57c-e47f3657b285>

To bid on the project, you will need to create a new Bid Portal account, even if you already have an e-Builder login. The Bid Portal is a separate platform within e-Builder.

- Bid Portal Video Tutorial Link: <https://vimeo.com/374214070>

Bidders are encouraged to log into the bid portal and submit a draft response at least 24 hrs. prior to bid opening. Bids can be withdrawn and resubmitted until the bid opening time shown above.

We strongly recommend that you give yourself sufficient time and **at least ONE (1) day** before the bid opening time to begin the uploading process and finalize your submission.

For informational purposes, project plans and specifications can be downloaded directly from the Bid Portal.

General Scope of Work:

Furnish all labor, equipment, materials, and incidentals to provide for Historic Cabins Repairs in accordance with the Contract Documents. The Engineer's Probable Opinion of Cost ranges from \$131,530.00 to \$138,530.00.

Project Schedule:

All work shall be completed within one hundred-eighty (180) calendar days commencing on the date specified in the Notice to Proceed. This performance period includes completing the various aspects required to complete the Work, including submission of all Submittals, mobilization, procurement, installation, testing, inspection and delivery of documents described in the Uniform General Conditions, Article 12, 12.1.1.1.

All bids must be submitted using the eBuilder Bid Portal. Each proposal must be accompanied by the required forms furnished for that purpose as well as the bid bond, or certified check made payable to the Texas Parks and Wildlife Department, in an amount of not less than (5) percent of the total bid amount. A photocopy of the bid bond or certified check may be uploaded through the Bid Portal; however, the physical copy must be received by TPWD at its headquarters location, 4200 Smith School Road, Austin Texas, 78744, Attn: Infrastructure Division, by 12:00 pm (noon) of the second business day following the bid submittal deadline.

Contact Information:

All questions related to this project should be directed to Misty K. Wyatt, CTCD, CTCM via the eBuilder Bid Portal Q&A board. The Q&A board can be accessed using the above eBuilder Bid Portal link.

Any questions *regarding the use of the Bid Portal for bidding* can be directed to misty.wyatt@tpwd.texas.gov.

TPWD reserves the right to reject any and all bids and to waive minor irregularities in the bidding process.

Non-Mandatory Pre-Bid Conference

A non-mandatory virtual pre-bid conference will be held on February 5, 2024 at 3:00 PM CST. Potential respondents must pre-register for the pre-bid conference by 2:45 PM, February 5, 2024, at:

<https://forms.office.com/g/ZwBwvsKqR6>

After registering, you will receive a confirmation e-mail containing information about joining the pre-bid conference. Although the pre-bid conference is not mandatory, Bidders are strongly encouraged to attend as important information regarding bid submittal requirements and an overview of the Project will be discussed.

The virtual pre-bid conference will be conducted using Microsoft® Teams. Bidders may use their browser to access the meeting or a Microsoft® Teams application.

Mandatory Site Visit

A mandatory site visit to view the project site will be held on February 6, 2024, at 2:00 PM CST at 199 Park Road 52, Stonewall, Texas, 78671. Bidders' attendance at the mandatory site visit is required in order to be eligible for contract award. TPWD shall reject responses submitted by Bidders that did not attend the mandatory site visit.

Supplemental Bidding Information

TPWD has selected to perform bid openings via virtual meetings. To facilitate virtual bid openings, TPWD will host all bid openings **one (1) hour after the bid opening deadline**. Interested attendees must register in advance to obtain information regarding the virtual bid opening.

Bid Opening Registration form: <https://forms.office.com/g/0k7XGAeEs0>

TEXAS PARKS AND WILDLIFE

INSTRUCTIONS TO BIDDERS

1. BID SUBMISSION:

1.1 Bids must be submitted electronically to the Infrastructure Division of the Texas Parks and Wildlife Department (TPWD) through the online eBuilder Bid Portal ("Bid Portal") NO LATER THAN the date and time specified in the Notice to Bidders. Only bids submitted through the Bid Portal will be accepted. Potential bidders are highly encouraged to prepare and submit their bid well ahead of the deadline in order to reduce the likelihood of any last-minute technical issues. Bids received after this time will not be accepted.

Note the following: The eBuilder Bid Portal is a separate platform. If you have not previously logged into the Bid Portal, you will need to create a new account separate from other eBuilder logins.

1.2 Corrections, deletions, or additions to bids must be made via the Bid Portal provided such changes are submitted in correct and comprehensive form prior to the opening time of bids. No email or telephonic instructions will be accepted. Bidders can make changes to their bids through the Bid Portal without any interaction from TPWD by recalling the bid, making revisions as necessary and resubmitting the bid. **TPWD shall NOT be responsible for failure of electronic equipment or operator error.**

1.3 Prepare the bid as defined in the Bid Scope tab of the eBuilder Bidding Module.

TPWD will not accept an incomplete bid. A bid that has one or more of the deficiencies listed below is considered incomplete:

- The proposal form was not signed,
- Certifications were not acknowledged,
- A regular item or the additive alternate item are left blank,
- A regular item and the corresponding replacement alternate item are left blank, or
- The Bidder did not acknowledge all addenda.

Award of contract shall be based upon the summation of the various unit price bids, but in case of error the unit prices shall govern, and computations will be checked for accuracy before award is made.

Prices will also be reviewed for balance prior to award, and obvious imbalance in favor of work scheduled for early completion or subject to significant expansion after award may be grounds for rejection of the bid.

1.4 Bidders are responsible for taking the appropriate measures to submit a bid. These measures include, but are not limited to acquiring hardware, software, and internet connectivity needed for submitting a bid via TPWD's bidding system. Bidders shall download, complete and submit the electronic proposal form found in the Bid Portal.

1.5 TPWD reserves the right to reject any or all bids-and to waive any or all informalities in connection therewith. TPWD does not bind itself to accept the lowest bid or any part thereof and reserves the right to ask for new bids for the whole or parts. The mere opening and reading aloud of a bid shall not constitute TPWD's acceptance of the suitability of a bidder or a bid. The competency and responsibility of the bidders will be considered in making an award. TPWD reserves the right to award, partially award, or not award a contract if no responses are deemed acceptable; and may re-solicit as determined necessary and in the best of the State of Texas.

2. **BASIS OF AWARD:** Base Bid Items 1-7 will be evaluated, and determination of the low bidder will be based on the lowest responsible base bid and/or a combination of the base bid and alternate bids. Alternates accepted will be considered in determining the low bidder, but TPWD does not obligate itself to accept an alternate or to accept alternates in any order listed unless otherwise stipulated elsewhere in the Invitation for Bids and Contract Documents.

3. **BID SECURITY:** Unless otherwise stipulated in the Invitation for Bids and Contract Documents, only projects in which the total contract price exceeds \$25,000.00, will require bid security. **Bids exceeding \$25,000.00 must be accompanied by a bid bond, certified check or cashier's check drawn to the order of the Texas Parks and Wildlife Department for not less than five percent (5%) of the total amount of the bid (including total of all separate bids for one or more projects bid and multiple base bids and/or alternate bids and/or optional bids and/or allowances).** Therefore, to ensure adequate bid security, bidders should calculate bid security based on the highest possible monetary award. A photocopy of the bid bond or certified check must be uploaded through the Bid Portal. **The physical copy must be received by TPWD at its headquarters location: 4200 Smith School Road, Austin, TX 78744, Attn: Infrastructure Division, by 12:00 pm (noon) of the second business day following the bid submittal deadline.** Certified checks and cashier checks must be originals. No other forms of bid security or checks will be accepted. **Bid will be rejected if the appropriate security is not furnished in the form specified above and the original is not received by noon of the second business day following the bid submittal deadline.**

Bid security for the three (3) lowest bidders may be retained by TPWD until the successful bidder executes the contract, and if required, furnishes bonds and certificates of insurance. All other bid security will be returned as soon as practical after bid opening.

Bid security for the successful bidder will be returned following execution of the contract and submission of satisfactory bonds and insurance. If the successful bidder fails to return the signed contract (and bonds and certificate of insurance when required) within the time specified, the bid security may be forfeited not as a penalty but as liquidated damages.

4. **INSURANCE REQUIREMENTS:** The successful Contractor must certify the minimum insurance coverages as set forth by the contract, specifically, the Uniform General Conditions, Article 5, 5.2. and Division 1 – General Requirements, Section 01000 – Special Conditions. The required insurance information shall be submitted within ten (10) calendar days from receipt of Notice of Selection. Failure to timely meet this requirement may result in disqualification of the bid and forfeiture of the bid security, if any. In such circumstances, TPWD shall be authorized to proceed with award to the next highest ranking, responsive and responsible bidder.

5. **BONDING REQUIREMENTS:** If the total contract price exceeds \$25,000.00, a Payment Bond must be furnished by the successful Contractor. If the total contract price exceeds \$100,000.00 a Payment Bond and a Performance Bond must be furnished by the successful Contractor. All bonds submitted shall use the TPWD provided form bearing original signatures. (See also Article 5, Uniform General Conditions). Owner reserves the right to reject a bond if the surety is not acceptable to TPWD.

6. **DISCREPANCIES:** Should any Bidder find discrepancies between the Invitation for Bids and Contract Documents, or should Bidder be in doubt as to their exact meaning, Bidder should notify TPWD at once. TPWD may then, at its option, issue addenda clarifying same. TPWD will not be responsible for oral instructions or for misinterpretation of Invitation for Bids and Contract Documents.

7. **ADDENDA:** TPWD reserves the right to issue addenda at any time prior to the bid opening.

(See also General Requirements – Special Conditions). Bidder shall acknowledge all addenda through the Bid Portal. Such acknowledgement must be made prior to the time and date specified for receipt of responses to this solicitation. Oral changes in the work made during the bidding period are not binding. **BIDDER'S FAILURE TO ACKNOWLEDGE ADDENDUM(S) MAY RESULT IN REJECTION OF BID.**

No oral explanation in regard to the meaning of the Invitation for Bids and Contract Documents will be made and no oral instructions will be given before the award of the contract. TPWD requests that all discrepancies, omissions, or questions as to the meaning of Drawings and Specifications shall be communicated electronically in writing to the Contract Manager for interpretation via the Bid Portal's Q&A Board.

- 8. PROHIBITED COMMUNICATIONS:** Upon issuance of this solicitation, TPWD, its representative(s), or partners will not answer questions or otherwise discuss the contents of this Solicitation with any potential Bidder or their representatives(s), except for the written inquiries described in the foregoing paragraph. Attempts to ask questions by phone or in person will not be allowed or recognized as valid.

Failure to observe this restriction may disqualify Bidder. Bidder shall rely only on written statements issued through or by TPWD's contracting staff. This restriction does not preclude discussions between affected parties for the purposes of conducting business unrelated to this solicitation.

- 9. LABOR LAWS:** Contractors must comply with all labor laws established by State and Federal statutes. (See also Article 2, Uniform General Conditions).

- 10. STATE SALES TAX:** Purchases made for State of Texas use are exempt from the State Sales Tax and Federal Excise Tax. TPWD will furnish Tax Exemption Certificates upon request. The Contractor represents and warrants that it shall pay all taxes or similar accounts resulting from the contract, including, but not limited to, any federal, state, or local income, sales, or excise taxes of Contractor or its employees. TPWD shall not be liable for any taxes resulting from this Contract.

The Contractor shall comply with applicable provisions of Chapter 34, Rules 3.291 and 3.357 of the Texas Administrative Code, or other procedures as may be prescribed by the State Comptroller of Public Accounts. Refer to Uniform General Conditions, Article. 2.

- 11. CONTRACTOR QUALIFICATIONS:** A Contractor's Statement of Qualifications must be submitted with the bid via the Bid Portal. Failure to properly complete and provide a Contractor's Statement of Qualifications shall be cause for the Contractor's bid being rejected by TPWD. TPWD may make such investigations as necessary to determine the ability of the Contractor to perform the work and reserves the right to reject any bid if the evidence submitted and/or obtained through investigation fails to satisfy TPWD that the Contractor is properly qualified to carry out the obligations of the Agreement.

MINIMUM EXPERIENCE REQUIREMENTS FOR THIS PROJECT:

CONTRACTOR MUST HAVE FIVE (5) YEARS HISTORIC MASONRY REPAIR PROJECT EXPERIENCE AND FIVE (5) YEARS HISTORIC STABILIZATION AND FOUNDATION REPAIR EXPERIENCE. CONTRACTOR MUST SHOW EVIDENCE OF THREE (3) SUCCESSFUL CONSTRUCTION PROJECTS SIMILAR TO THIS PROJECT (AS JUDGED BY OWNER) TO BE ELIGIBLE FOR AWARD OF THIS CONTRACT. THIS EXPERIENCE MUST HAVE OCCURRED WITHIN THE PAST FIVE (5) YEARS, MEASURED BACKWARDS FROM THE ISSUE DATE OF THIS SOLICITATION.

- 12. VENDOR PERFORMANCE TRACKING SYSTEM:** In evaluating responses, the Owner will consider information related to past contract performance of a Bidder including, but not limited

to CPA's Vendor Performance Tracking System (VPTS) available at <http://www.txsmartbuy.com/vpts>. Prior work performance with the Owner and other state agencies or governmental entities which are familiar with a Bidder's performance, depending on problems encountered, may be grounds for disqualification. In addition, Bidders involved in litigation with the Owner or another state agency may be disqualified.

- 13. HISTORICALLY UNDERUTILIZED BUSINESS REPRESENTATIONS & CERTIFICATIONS: BIDDERS ARE ADVISED THAT**, in accordance with Texas Government Code, Sections 2161.181-182 and Title 34, Chapter 20, Subchapter B., 20.285 of the Texas Administrative Code (TAC), state agencies must make good faith effort to utilize Historically Underutilized Businesses (HUBs) in contracts for construction services, professional and consulting services and commodities contracts with an expected value of \$100,000.00 or more. **Each bidder must complete and return with the bid one (1) electronic/digital version of its HUB Subcontracting Plan (HSP) following the policy and utilizing the forms contained with the Invitation for Bids and Contract Documents included herein. FAILURE TO COMPLETE AND RETURN THESE FORMS WITH THE BID WILL BE CAUSE FOR REJECTION OF THE BID. THE CONTRACTOR RECEIVING AN AWARD MUST COMPLY WITH THE SPECIAL REQUIREMENTS SPECIFIED HEREIN. For questions, call HUB Staff, 512/389-4784. An instructional video, Microsoft Word® documents and PowerPoint® presentation can be located at:**

<http://tpwd.texas.gov/business/bidops/hub/HSP/index.phtml>.

- 14. TIE BIDS:** If the official total bid amount for two or more Bidders is equal and those bids are the lowest submitted, each tie Bidder will be given an opportunity to withdraw their bid. If two or more Bidders do not withdraw their bids, the low Bidder will be determined by a coin toss or a series of coin tosses when there are more than two Bidders. If all tie Bidders request to withdraw their bids, no withdrawals will be allowed, and the low Bidder will be determined by a coin toss or a series of coin tosses when there are more than two Bidders. The Contract Manager will preside over the proceedings.
- 15. PROTEST PROCEDURES:** Any Actual or prospective Respondent who is aggrieved in connection with this solicitation, evaluation, or award of any contract resulting from this solicitation may formally protest as provided in TPWD's rules at [TAC, Title 31, Part 2, Chapter 51, Subchapter L, Rule 51.350](#).
- 16. TERMS AND CONDITIONS ATTACHED TO RESPONSE:** Any terms and conditions attached to a response will not be considered unless specifically referred to in the bid.
- 17. REMOTE VIRTUAL INSPECTIONS:** Contractor may be required to facilitate Remote Virtual Inspections (RVI). Contractor will be required to sign TPWD's REMOTE VIRTUAL INSPECTION AGREEMENT, a draft of which is included as an attachment in the solicitation documents.
- 18. Reserved**
- 19. Reserved**
- 20. Reserved**
- 21. Reserved**

CONTRACTOR'S BID SUBMITTALS

TEXAS PARKS AND WILDLIFE

BIDDER AFFIRMATIONS

A FULLY EXECUTED COPY OF THIS FORM IN ITS ENTIRETY MUST BE UPLOADED WITH YOUR BID INTO TPWD'S BIDDING PORTAL

BASE BID ITEMS 1 – 7 will be evaluated, and determination of the low bidder will be based on responsiveness and responsibility of the bidder and on the BASE BID. HOWEVER, THE OWNER RESERVES THE RIGHT TO AWARD TO THE LOW BIDDER ANY COMBINATION OF BID ITEMS OR TO REJECT ALL BIDS.

BIDDER UNDERSTANDS AND ACKNOWLEDGES THAT BIDDER MUST MEET THE MINIMUM QUALIFICATION AND/OR EXPERIENCE REQUIREMENTS SET FORTH IN PARAGRAPH 11 OF INSTRUCTIONS TO BIDDERS TO BE ELIGIBLE FOR AWARD OF THIS CONTRACT. BIDDER, BY SIGNING THIS BID, AFFIRMS THAT BIDDER MEETS SUCH MINIMUM REQUIREMENTS. FAILURE TO MEET ANY OF THE MINIMUM QUALIFICATIONS SHALL RESULT IN REJECTION OF THE BID.

The undersigned further agrees that, if awarded the Contract, the work will be completed within **one hundred-eighty (180)** calendar days commencing on the date specified in the Notice to Proceed. This performance period includes completing the various aspects required to complete the Work, including submittal of all required Submittals, mobilization, procurement, installation, testing, inspection, and delivery of documents described in the Uniform General Conditions, Article 12, 12.1.1.1.

The undersigned agrees that when written notice of bid acceptance is furnished by the Owner within **sixty (60)** calendar days after the bid opening date, the undersigned will, within the stipulated time, execute and deliver the contract and all required bonds, certificates of insurance, submittals, and Form 1295 to the Owner. Failure to timely provide the insurance certificate, bonds, and submittals shall be grounds for disqualification of bid and forfeiture of bid security. In such circumstances, TPWD shall be authorized to proceed with award to the next lowest, responsive, and responsible bidder.

If the above bid amount exceeds \$25,000.00, the undersigned shall include herewith security in the form of a bid bond, certified check, or cashier's check for an amount not less than five percent (5%) of the total amount of the bid to be awarded by Owner, unless otherwise stipulated under Instructions to Bidders. To ensure adequate bid security, bidders should calculate bid security based on the total amount of all base bids plus all additive alternate bids (if any). The bid security will be returned to or forfeited by the undersigned in accordance with the Bid Security provision in the Instructions to Bidders. The undersigned further agrees that this bid security is the appropriate measure of liquidated damages which the Owner will sustain by the failure of the undersigned to execute and deliver said contract and required documents.

The undersigned agrees that this bid will not be withdrawn for a period of **sixty (60)** calendar days from the date set for the bid opening, and the undersigned further agrees that the bid security will be forfeited in the event this bid is withdrawn before expiration of said **sixty (60)** calendar days.

Bidders represents and warrants that if selected for award of a contract as a result of the Solicitation, bidder will submit to TPWD a Certificate of Interested Parties prior to contract execution in accordance with Section 2252.908 of the Texas Government Code.

Additional information can be found at:

https://www.ethics.state.tx.us/whatsnew/elf_info_form1295.htm

Bidder represents and warrants that, in accordance with Section 2155.005 of the Texas Government Code, neither the bidder, nor the firm, corporation, partnership, or institution represented by the bidder, or anyone acting for such firm, corporation, or institution has (1) violated any provision of the Texas Free Enterprise and Antitrust Act of 1983, Chapter 15 of the *Texas Business and Commerce Code*, or the Federal antitrust laws, or (2) communicated directly or indirectly the contents of this bid to any competitor or any other person engaged in the same line of business as the bidder.

Pursuant to *Texas Government Code*, Title 10, Subchapter A, §2155.004(a), Bidder certifies that neither bidder nor any person or entity represented by bidder has received compensation from TPWD to participate in the preparation of the specifications or solicitation on which this bid or contract is based. Under §2155.004(b) of the Texas Government Code, Bidder certifies that the individual or business entity named in this bid or contract is not ineligible to receive the specified contract and acknowledges that the contract may be terminated, and payment withheld if this certification is inaccurate.

Pursuant to *Texas Government Code*, Title 10, Subchapter A, §2155.004(b), §2155.006(c), and Subchapter B, §2261.053(c), Bidder certifies that the individual or business entity named in this bid is not ineligible to receive the specified contract and acknowledges that this contract may be terminated, and payment withheld if this certification is inaccurate.

By signature hereon, the bidder hereby certifies that he/she is not currently delinquent in the payment of any franchise taxes owed the State of Texas under Chapter 171, Tax Code. Making a false statement as to corporate tax status is a material breach of contract.

Bidder certifies that the bidding entity and its principals are eligible to participate in this transaction and have not been subjected to suspension, debarment, or similar ineligibility determined by any federal, state or local governmental entity. Entities ineligible for federal procurement are listed at <http://www.sam.gov>.

Bidder certifies that it is not listed in the prohibited vendors list authorized by Executive Order No. 13224, "Blocking Property and Prohibiting Transactions with Persons Who Commit, Threaten to Commit, or Support Terrorism", published by the United States Department of the Treasury, Office of Foreign Assets Control.

Under Section 2155.0061 of the Texas Government Code, the Bidder certifies that the individual or business entity named in this Response or contract is not ineligible to receive the specified contract and acknowledges that this contract may be terminated, and payment withheld if this certification is inaccurate.

Pursuant to Section 2155.003 of the Texas Government Code, bidder represents and warrants

that it has not given, offered to give, nor intends to give at any time hereafter any economic opportunity, future employment, gift, loan, gratuity, special discount, trip, favor or service to a public servant in connection with the contract.

Bidder agrees that any payments due under this contract shall be applied towards any debt or delinquency that is owed to the State of Texas.

Bidder represents and warrants its compliance with the requirements of the Americans with Disabilities Act (ADA) and its implementing regulations, as each may be amended.

Bidder agrees to comply with *Texas Government Code*, Title 10, Subtitle D, §2155.4441, relating to use of service contracts and the purchase of products and materials produced in the State of Texas.

Bidder certifies that if a Texas address is shown as the address of the Bidder on this bid, Bidder qualifies as a Texas Bidder as defined in Section 2155.444(c) of the Texas Government Code.

If Bidder is required to make a certification pursuant to Section 2271.001 of the Texas Government Code, Bidder certifies that Bidder does not boycott Israel and will not boycott Israel during the term of the contract resulting from this solicitation. If Bidder does not make that certification, Bidder must indicate that in its Bid and state why the certification is not required.

Section 2252.152 of the Texas Government Code prohibits TPWD from awarding a contract to any person who does business with Iran, Sudan, or a foreign terrorist organization as defined in Section 2252.151 of the Texas Government Code. Bidder certifies that it is not ineligible to receive the contract.

Under Section 161.0085 of the Texas Health and Safety Code, Bidder certifies that the individual or business entity named in this Response or contract is not ineligible to receive the specified contract.

By signature hereon, the bidder acknowledges that *Texas Government Code*, Title 10, Subchapter F, §§ 2252.201-2252.205 requires that all iron or steel products produced through a manufacturing process used in this project must be produced in the United States. By signing this bid, Bidder certifies that its bid price represents full compensation for compliance with the requirements of *Texas Government Code*, Title 10, Subchapter F, §§ 2252.201-2252.205.

Bidder represents and warrants that: (1) it does not, and will not for the duration of the contract, boycott energy companies or (2) the verification required by Section 2274.002 of the Texas Government Code does not apply to the contract. If circumstances relevant to this provision change during the course of the contract, Bidder shall promptly notify Owner.

Bidder verifies that: (1) it does not, and will not for the duration of the contract, have a practice, policy, guidance, or directive that discriminates against a firearm entity or firearm trade association or (2) the verification required by Section 2274.002 of the Texas Government Code does not apply to the contract. If circumstances relevant to this provision change during the course of the contract, Bidder shall promptly notify Owner.

Pursuant to Section 2274.0102 of the Texas Government Code, Bidder certifies that neither it nor its parent company, nor any affiliate of the Bidder or its parent company, is: (1) majority owned or controlled by citizens or governmental entities of China, Iran, North Korea, Russia, or any other country designated by the Governor under Government Code Section 2274.0103, or (2) headquartered in any of those countries.

Pursuant to Section 2254.0031 of the Texas Government Code, which incorporates by reference Section 271.904(d) of the Texas Local Government Code, Bidder shall perform services (1) with professional skill and care ordinarily provided by competent engineers or architects practicing under the same or similar circumstances and professional license, and (2) as expeditiously as is prudent considering the ordinary professional skill and care of a competent engineer or architect.

By signing this bid, Bidder acknowledges and understands that the acceptance of funds by the Bidder or any other entity or person directly under this Contract, or indirectly through a subcontract under this Contract, shall constitute acceptance of the authority of the State Auditor's Office, Comptroller, or other agency of the State of Texas, TPWD or any successor agency, to conduct an audit or investigation in connection with those funds. The Bidder further agrees to cooperate fully with the above parties in the conduct of the audit or investigation, including providing access to any information the state auditor considers relevant to the investigation or audit. The Bidder shall ensure that this paragraph concerning the State's authority to audit funds received indirectly by subcontractors through the Bidder and the requirement to cooperate is included in any subcontract it awards.

Bidder represents and warrants that the provision of goods and services or other performance under the contract will not constitute an actual or potential conflict of interest or reasonably create an appearance of impropriety.

Under Section 231.006(d) of the Texas Family Code, regarding child support, the Bidder certifies that the individual or business entity named in this bid is not ineligible to receive the specified payment and acknowledges that the contract may be terminated, and payment may be withheld if this certification is inaccurate.

Under Section 669.003 of the *Texas Government Code*, Bidder certifies that it does not employ, or has disclosed its employment of, any former executive head of the agency. Bidder must provide the following information in the bid.

Name of former executive: _____

Name of State agency: _____

Date of separation from State agency: _____

Position with Bidder: _____

Date of employment with Bidder: _____

Bidder should acknowledge all addendum(s) with their bid submission via the Bid Portal. Oral changes in the work made during the bidding period are not binding. **BIDDER'S FAILURE TO ACKNOWLEDGE EACH ADDENDUM WITH THEIR BID MAY RESULT IN REJECTION OF BID.**

BIDDER'S AFFIRMATION: SIGNING THIS BID WITH A FALSE STATEMENT OR MATERIAL MISREPRESENTATIONS MADE DURING THE PERFORMANCE OF A CONTRACT IS A MATERIAL BREACH OF CONTRACT AND SHALL VOID THE SUBMITTED BID OR ANY RESULTING CONTRACTS.

The undersigned certifies that I am duly authorized to submit this bid and execute a contract on my own behalf or on behalf of the bidder listed below.

Name of Contracting Firm	By	Authorized Signature	Date
Address		Printed Name	
City	State	Zip	Title
(Area Code) Phone Number		(Area Code) Phone Number	
Email address		(Area Code) Cell Phone Number	
Texas Identification Number/Vendor ID		Federal Employers Identification Number (EIN)	

A FULLY EXECUTED COPY OF THIS FORM IN ITS ENTIRETY MUST BE UPLOADED WITH YOUR BID INTO TPWD'S BIDDING PORTAL

TEXAS PARKS AND WILDLIFE

CONTRACTOR'S QUALIFICATION STATEMENT

Bidder shall use this form to clearly demonstrate how they meet the requirements set forth in this solicitation. **Failure to complete and submit this form in its entirety through the Bid Portal may result in the response submission being considered non-responsive.**

ALL FORM FIELDS REQUIRED. MARK N/A IF NOT APPLICABLE

Section One: Company Profile

Legal Name of the Company:	
Company Description:	
Principal place of business (<i>Corporate Headquarters</i>):	
Address:	
City, State, Zip:	
Facility responsible for servicing the contract:	
Address:	
City, State, Zip:	
Contact Person regarding company's submission to the solicitation, authorized to render binding decisions on contract matters:	
Name & Title:	
Phone & Email:	
Personnel who will be responsible for management and day-to-day operation of services described in this solicitation.	
Name & Title:	
Phone & Email:	
Indicate if your company or any of its subsidiaries filed or met criteria for bankruptcy within the last five years. __ Yes __ No If yes, explain.	
Identify if your firm is currently in default on any loan agreement or financing agreement with any bank, financial institution, or other entity? If so, specify date(s), details, circumstances and prospects for resolution.	

Identify if your firm is currently for sale or involved in any transaction to expand or to become acquired by another business entity? If so, please explain the impact both in organization and company direction.

Indicate if your company or any of its subsidiaries has been involved in litigation within the last five years.
 Yes No If yes, explain.

--

Number years in business:		Number of employees:	
---------------------------	--	----------------------	--

PRINCIPALS IN FIRM AND YEARS EXPERIENCE IN CONSTRUCTION

NAME	TITLE	PHONE	NO. OF YEARS

Has firm, under its current or former name(s) ever failed to complete a project, defaulted on a contract, or been engaged in litigation over a contract? Yes No. If so, state particulars of most recent occurrence on separate sheet(s) and attach to this form.

FIRM HISTORY: List firm history below including any other business names used

From		to		Firm Name	
From		to		Firm Name	
From		to		Firm Name	
From		to		Firm Name	

CONSTRUCTION CAPABILITIES

Firms Average Annual Construction Volume	\$
--	----

Building	%	Mech.-HVAC	%	Hwy/Roads	%	Other	%
Electrical	%	Utility Lines	%	Earthwork	%	Other	%
Plumbing	%	Utility Plants	%	Site Work	%	Other	%

Section Two: Contractor's Financial Information

BONDING INFORMATION: Indicate agency/surety through which bonding will be obtained.

Agency:	
Agent's Name:	
Address:	
Address:	
Email Address:	
Agent's Phone No.:	
BONDING COMPANY (UNDERWRITER)	
Bonding Company Name:	
Bonding Agent's Address:	
Bonding Agent's Email:	
Bonding Agent's Phone:	

Section Three: Company Experience Record

List minimum of three (3) projects (attach additional sheets if necessary) that are at least 50% completed (*50% completed projects will be counted towards successful projects*) or have been completed within the last (5) years and that demonstrate similar experience. Refer to Instructions to Bidders – Article 11.

PROJECT 1:

Project Name/Location	
Project Owner's Name	
Project Owner's Address	
Owner's Representative for this Project	
Owner's Representative Phone/Email Address	
Performance Period of this Project (no. of calendar days)	
Contract Start Date	
Contract Completion Date	
Provide a brief explanation for time extensions granted on this Project	
Original Contract Amount	\$

Final Contract Amount	\$
If Project is still under construction, then provide percentage complete	
Offeror's key personnel, including Project Superintendent & major subcontractors, including address, telephone and email address:	
Brief Description of the Work:	
Describe how this Project is comparable to the Work required for this Project:	
If applicable, Project A/E Name, phone number and email address:	

Project 2:

Project Name/Location	
Project Owner's Name	
Project Owner's Address	
Owner's Representative for this Project	
Owner's Representative Phone/Email Address	
Performance Period of this Project (no. of calendar days)	
Contract Start Date	
Contract Completion Date	
Provide a brief explanation for time extensions granted on this Project	
Original Contract Amount	\$
Final Contract Amount	\$
If Project is still under construction, then provide percentage complete	
Offeror's key personnel, including Project Superintendent & major subcontractors, including address, telephone and email address:	
Brief Description of the Work:	
Describe how this Project is comparable to the Work required for this Project:	
If applicable, Project A/E Name, phone number and email address:	

Project 3:

Project Name/Location	
Project Owner's Name	
Project Owner's Address	
Owner's Representative for this Project	
Owner's Representative Phone/Email Address	
Performance Period of this Project (no. of calendar days)	
Contract Start Date	
Contract Completion Date	
Provide a brief explanation for time extensions granted on this Project	
Original Contract Amount	\$
Final Contract Amount	\$
If Project is still under construction, then provide percentage complete	
Offeror's key personnel, including Project Superintendent & major subcontractors, including address, telephone and email address:	
Brief Description of the Work:	
Describe how this Project is comparable to the Work required for this Project:	
If applicable, Project A/E Name, phone number and email address:	

Project 4:

Project Name/Location	
Project Owner's Name	
Project Owner's Address	
Owner's Representative for this Project	
Owner's Representative Phone/Email Address	
Performance Period of this Project (no. of calendar days)	
Contract Start Date	
Contract Completion Date	
Provide a brief explanation for time extensions granted on this Project	
Original Contract Amount	\$
Final Contract Amount	\$
If Project is still under construction, then provide percentage complete	
Offeror's key personnel, including Project Superintendent & major subcontractors, including address, telephone and email address:	
Brief Description of the Work:	
Describe how this Project is comparable to the Work required for this Project:	
If applicable, Project A/E Name, phone number and email address:	

Project 5:

Project Name/Location	
Project Owner's Name	
Project Owner's Address	
Owner's Representative for this Project	
Owner's Representative Phone/Email Address	
Performance Period of this Project (no. of calendar days)	
Contract Start Date	
Contract Completion Date	
Provide a brief explanation for time extensions granted on this Project	
Original Contract Amount	\$
Final Contract Amount	\$
If Project is still under construction, then provide percentage complete	
Offeror's key personnel, including Project Superintendent & major subcontractors, including address, telephone and email address:	
Brief Description of the Work:	
Describe how this Project is comparable to the Work required for this Project:	
If applicable, Project A/E Name, phone number and email address:	

Section Four: HUB Information

Is your firm a Texas Certified Historically Underutilized Business? (HUB): Yes No

If yes, please indicate gender and ethnicity:

Gender: Male Female

Ethnicity: Asian Pacific Islander , Black American , Hispanic American , Native American

Service-Disabled Veteran: Yes No

Section Five: TPWD Contracting Experience

Has firm ever done business with TPWD? Yes No

If yes, list the most recent project Information:

TPWD Project No.:	
Project Title and Location:	
Offeror's key personnel, including Project Superintendent & major subcontractors, including address, telephone and email address:	
Brief Description of the Work:	

Describe how this Project is comparable to the Work required for this Project:

Additional TPWD Projects, if any

Project No./ Contract No.	Project Location	Project Title

Section Six: Certifications and Signature

I hereby certify that all information provided above and attached is true and correct. Furthermore, I hereby authorize Texas Parks and Wildlife Department to contact the references listed above and authorize release of information from such references to Texas Parks and Wildlife Department. I certify that my firm is not debarred or suspended from performing work for the U.S.A. or the State of Texas.

Name of Firm

Signature of Owner or Officer

Title of Person Signing

Date

COMPLETE ALL SECTIONS OF THIS FORM AND SUBMIT WITH BID IN THE BID PORTAL.



HUB Subcontracting Plan (HSP) QUICK CHECKLIST

While this HSP Quick Checklist is being provided to merely assist you in readily identifying the sections of the HSP form that you will need to complete, it is very important that you adhere to the instructions in the HSP form and instructions provided by the contracting agency.

- **If you will be awarding all of the subcontracting work you have to offer under the contract to only Texas certified HUB vendors, complete:**
 - Section 1 - Respondent and Requisition Information
 - Section 2 a. - Yes, I will be subcontracting portions of the contract.
 - Section 2 b. - List all the portions of work you will subcontract, and indicate the percentage of the contract you expect to award to Texas certified HUB vendors.
 - Section 2 c. - Yes
 - Section 4 - Affirmation
 - GFE Method A (Attachment A) - Complete an Attachment A for each of the subcontracting opportunities you listed in Section 2 b.
- **If you will be subcontracting any portion of the contract to Texas certified HUB vendors and Non-HUB vendors, and the aggregate percentage of all the subcontracting work you will be awarding to the Texas certified HUB vendors with which you do not have a continuous contract* in place for more than five (5) years meets or exceeds the HUB Goal the contracting agency identified in the "Agency Special Instructions/Additional Requirements", complete:**
 - Section 1 - Respondent and Requisition Information
 - Section 2 a. - Yes, I will be subcontracting portions of the contract.
 - Section 2 b. - List all the portions of work you will subcontract, and indicate the percentage of the contract you expect to award to Texas certified HUB vendors and Non-HUB vendors.
 - Section 2 c. - No
 - Section 2 d. - Yes
 - Section 4 - Affirmation
 - GFE Method A (Attachment A) - Complete an Attachment A for each of the subcontracting opportunities you listed in Section 2 b.
- **If you will be subcontracting any portion of the contract to Texas certified HUB vendors and Non-HUB vendors or only to Non-HUB vendors, and the aggregate percentage of all the subcontracting work you will be awarding to the Texas certified HUB vendors with which you do not have a continuous contract* in place for more than five (5) years does not meet or exceed the HUB Goal the contracting agency identified in the "Agency Special Instructions/Additional Requirements", complete:**
 - Section 1 - Respondent and Requisition Information
 - Section 2 a. - Yes, I will be subcontracting portions of the contract.
 - Section 2 b. - List all the portions of work you will subcontract, and indicate the percentage of the contract you expect to award to Texas certified HUB vendors and Non-HUB vendors.
 - Section 2 c. - No
 - Section 2 d. - No
 - Section 4 - Affirmation
 - GFE Method B (Attachment B) - Complete an Attachment B for each of the subcontracting opportunities you listed in Section 2 b.
- **If you will not be subcontracting any portion of the contract and will be fulfilling the entire contract with your own resources (i.e., employees, supplies, materials and/or equipment), complete:**
 - Section 1 - Respondent and Requisition Information
 - Section 2 a. - No, I will not be subcontracting any portion of the contract, and I will be fulfilling the entire contract with my own resources.
 - Section 3 - Self Performing Justification
 - Section 4 - Affirmation

***Continuous Contract:** Any existing written agreement (including any renewals that are exercised) between a prime contractor and a HUB vendor, where the HUB vendor provides the prime contractor with goods or service, to include under the same contract for a specified period of time. The frequency the HUB vendor is utilized or paid during the term of the contract is not relevant to whether the contract is considered continuous. Two or more contracts that run concurrently or overlap one another for different periods of time are considered by CPA to be individual contracts rather than renewals or extensions to the original contract. In such situations the prime contractor and HUB vendor are entering (have entered) into "new" contracts.



HUB Subcontracting Plan (HSP)

In accordance with Texas Gov't Code §2161.252, the contracting agency has determined that subcontracting opportunities are probable under this contract. Therefore, all respondents, including State of Texas certified Historically Underutilized Businesses (HUBs) must complete and submit this State of Texas HUB Subcontracting Plan (HSP) with their response to the bid requisition (solicitation).

NOTE: Responses that do not include a completed HSP shall be rejected pursuant to Texas Gov't Code §2161.252(b).

The HUB Program promotes equal business opportunities for economically disadvantaged persons to contract with the State of Texas in accordance with the goals specified in the 2009 State of Texas Disparity Study. The statewide HUB goals defined in 34 Texas Administrative Code (TAC) §20.284 are:

- **11.2 percent for heavy construction other than building contracts,**
- **21.1 percent for all building construction, including general contractors and operative builders' contracts,**
- **32.9 percent for all special trade construction contracts,**
- **23.7 percent for professional services contracts,**
- **26.0 percent for all other services contracts, and**
- **21.1 percent for commodities contracts.**

- - Agency Special Instructions/Additional Requirements - -

*In accordance with 34 TAC §20.285(d)(1)(D)(iii), a respondent (prime contractor) may demonstrate good faith effort to utilize Texas certified HUBs for its subcontracting opportunities if the total value of the respondent's subcontracts with Texas certified HUBs meets or exceeds the statewide HUB goal or the agency specific HUB goal, whichever is higher. When a respondent uses this method to demonstrate good faith effort, the respondent must identify the HUBs with which it will subcontract. If using existing contracts with Texas certified HUBs to satisfy this requirement, only the aggregate percentage of the contracts expected to be subcontracted to HUBs with which the respondent **does not** have a **continuous contract*** in place for **more than five (5) years** shall qualify for meeting the HUB goal. This limitation is designed to encourage vendor rotation as recommended by the 2009 Texas Disparity Study.*

SECTION 1: RESPONDENT AND REQUISITION INFORMATION

- a. Respondent (Company) Name: _____ State of Texas VID #: _____
 Point of Contact: _____ Phone #: _____
 E-mail Address: _____ Fax #: _____
- b. Is your company a State of Texas certified HUB? - Yes - No
- c. Requisition #: _____ Bid Open Date: _____

(mm/dd/yyyy)

Enter your company's name here: _____ Requisition #: _____

SECTION 2: RESPONDENT'S SUBCONTRACTING INTENTIONS

After dividing the contract work into reasonable lots or portions to the extent consistent with prudent industry practices, and taking into consideration the scope of work to be performed under the proposed contract, including all potential subcontracting opportunities, the respondent must determine what portions of work, **including contracted staffing, goods and services will be subcontracted**. Note: In accordance with 34 TAC §20.282, a "Subcontractor" means a person who contracts with a prime contractor to work, to supply commodities, or to contribute toward completing work for a governmental entity.

a. Check the appropriate box (Yes or No) that identifies your subcontracting intentions:

- *Yes*, I will be subcontracting portions of the contract. (If *Yes*, complete Item b of this SECTION and continue to Item c of this SECTION.)
- *No*, I will not be subcontracting any portion of the contract, and I will be fulfilling the entire contract with my own resources, including employees, goods and services. (If *No*, continue to SECTION 3 and SECTION 4.)

b. List all the portions of work (subcontracting opportunities) you will subcontract. Also, based on the total value of the contract, identify the percentages of the contract you expect to award to Texas certified HUBs, and the percentage of the contract you expect to award to vendors that are not a Texas certified HUB (i.e., Non-HUB).

Item #	Subcontracting Opportunity Description	HUBs		Non-HUBs
		Percentage of the contract expected to be subcontracted to HUBs with which you do not have a continuous contract* in place for more than five (5) years .	Percentage of the contract expected to be subcontracted to HUBs with which you have a continuous contract* in place for more than five (5) years .	Percentage of the contract expected to be subcontracted to non-HUBs.
1		%	%	%
2		%	%	%
3		%	%	%
4		%	%	%
5		%	%	%
6		%	%	%
7		%	%	%
8		%	%	%
9		%	%	%
10		%	%	%
11		%	%	%
12		%	%	%
13		%	%	%
14		%	%	%
15		%	%	%
Aggregate percentages of the contract expected to be subcontracted:		%	%	%

(Note: If you have more than fifteen subcontracting opportunities, a continuation sheet is available online at <https://www.comptroller.texas.gov/purchasing/vendor/hub/forms.php>.)

c. Check the appropriate box (Yes or No) that indicates whether you will be using **only** Texas certified HUBs to perform **all** of the subcontracting opportunities you listed in SECTION 2, Item b.

- *Yes* (If *Yes*, continue to SECTION 4 and complete an "HSP Good Faith Effort - Method A (Attachment A)" for **each** of the subcontracting opportunities you listed.)
- *No* (If *No*, continue to Item d, of this SECTION.)

d. Check the appropriate box (Yes or No) that indicates whether the aggregate expected percentage of the contract you will subcontract **with Texas certified HUBs** with which you **do not** have a **continuous contract*** in place with for **more than five (5) years**, **meets or exceeds** the HUB goal the contracting agency identified on page 1 in the "Agency Special Instructions/Additional Requirements."

- *Yes* (If *Yes*, continue to SECTION 4 and complete an "HSP Good Faith Effort - Method A (Attachment A)" for **each** of the subcontracting opportunities you listed.)
- *No* (If *No*, continue to SECTION 4 and complete an "HSP Good Faith Effort - Method B (Attachment B)" for **each** of the subcontracting opportunities you listed.)

***Continuous Contract:** Any existing written agreement (including any renewals that are exercised) between a prime contractor and a HUB vendor, where the HUB vendor provides the prime contractor with goods or service under the same contract for a specified period of time. The frequency the HUB vendor is utilized or paid during the term of the contract is not relevant to whether the contract is considered continuous. Two or more contracts that run concurrently or overlap one another for different periods of time are considered by CPA to be individual contracts rather than renewals or extensions to the original contract. In such situations the prime contractor and HUB vendor are entering (have entered) into "new" contracts.

Enter your company's name here: _____ Requisition #: _____

SECTION 2: RESPONDENT'S SUBCONTRACTING INTENTIONS (CONTINUATION SHEET)

This page can be used as a continuation sheet to the HSP Form's page 2, Section 2, Item b. Continue listing the portions of work (subcontracting opportunities) you will subcontract. Also, based on the total value of the contract, identify the percentages of the contract you expect to award to Texas certified HUBs, and the percentage of the contract you expect to award to vendors that are not a Texas certified HUB (i.e., Non-HUB).

Item #	Subcontracting Opportunity Description	HUBs		Non-HUBs
		Percentage of the contract expected to be subcontracted to HUBs with which you do not have a continuous contract* in place for more than five (5) years .	Percentage of the contract expected to be subcontracted to HUBs with which you have a continuous contract* in place for more than five (5) years .	Percentage of the contract expected to be subcontracted to non-HUBs.
16		%	%	%
17		%	%	%
18		%	%	%
19		%	%	%
20		%	%	%
21		%	%	%
22		%	%	%
23		%	%	%
24		%	%	%
25		%	%	%
26		%	%	%
27		%	%	%
28		%	%	%
29		%	%	%
30		%	%	%
31		%	%	%
32		%	%	%
33		%	%	%
34		%	%	%
35		%	%	%
36		%	%	%
37		%	%	%
38		%	%	%
39		%	%	%
40		%	%	%
41		%	%	%
42		%	%	%
43		%	%	%
Aggregate percentages of the contract expected to be subcontracted:		%	%	%

***Continuous Contract:** Any existing written agreement (including any renewals that are exercised) between a prime contractor and a HUB vendor, where the HUB vendor provides the prime contractor with goods or service under the same contract for a specified period of time. The frequency the HUB vendor is utilized or paid during the term of the contract is not relevant to whether the contract is considered continuous. Two or more contracts that run concurrently or overlap one another for different periods of time are considered by CPA to be individual contracts rather than renewals or extensions to the original contract. In such situations the prime contractor and HUB vendor are entering (have entered) into "new" contracts.

Enter your company's name here: _____ Requisition #: _____

SECTION 3: SELF PERFORMING JUSTIFICATION (If you responded "No" to SECTION 2, Item a, you must complete this SECTION and continue to SECTION 4.) If you responded "No" to SECTION 2, Item a, in the space provided below **explain how** your company will perform the entire contract with its own employees, supplies, materials and/or equipment.

SECTION 4: AFFIRMATION

As evidenced by my signature below, I affirm that I am an authorized representative of the respondent listed in SECTION 1, and that the information and supporting documentation submitted with the HSP is true and correct. Respondent understands and agrees that, if awarded any portion of the requisition:

- The respondent will provide notice as soon as practical to all the subcontractors (HUBs and Non-HUBs) of their selection as a subcontractor for the awarded contract. The notice must specify at a minimum the contracting agency's name and its point of contact for the contract, the contract award number, the subcontracting opportunity they (the subcontractor) will perform, the approximate dollar value of the subcontracting opportunity and the expected percentage of the total contract that the subcontracting opportunity represents. A copy of the notice required by this section must also be provided to the contracting agency's point of contact for the contract no later than ten (10) working days after the contract is awarded.
- The respondent must submit monthly compliance reports (Prime Contractor Progress Assessment Report – PAR) to the contracting agency, verifying its compliance with the HSP, including the use of and expenditures made to its subcontractors (HUBs and Non-HUBs). (The PAR is available at <https://www.comptroller.texas.gov/purchasing/docs/hub-forms/ProgressAssessmentReportForm.xls>).
- The respondent must seek approval from the contracting agency prior to making any modifications to its HSP, including the hiring of additional or different subcontractors and the termination of a subcontractor the respondent identified in its HSP. If the HSP is modified without the contracting agency's prior approval, respondent may be subject to any and all enforcement remedies available under the contract or otherwise available by law, up to and including debarment from all state contracting.
- The respondent must, upon request, allow the contracting agency to perform on-site reviews of the company's headquarters and/or work-site where services are being performed and must provide documentation regarding staffing and other resources.

Signature	Printed Name	Title	Date (mm/dd/yyyy)
-----------	--------------	-------	----------------------

Reminder:

- If you responded "Yes" to SECTION 2, Items c or d, you must complete an "HSP Good Faith Effort - Method A (Attachment A)" for each of the subcontracting opportunities you listed in SECTION 2, Item b.
- If you responded "No" SECTION 2, Items c and d, you must complete an "HSP Good Faith Effort - Method B (Attachment B)" for each of the subcontracting opportunities you listed in SECTION 2, Item b.

HSP Good Faith Effort - Method A (Attachment A)

Rev. 2/17

Enter your company's name here: _____ Requisition #: _____

IMPORTANT: If you responded "Yes" to **SECTION 2, Items c or d** of the completed HSP form, you must submit a completed "HSP Good Faith Effort - Method A (Attachment A)" for each of the subcontracting opportunities you listed in **SECTION 2, Item b** of the completed HSP form. You may photo-copy this page or download the form at <https://www.comptroller.texas.gov/purchasing/docs/hub-forms/hub-sbcont-plan-gfe-achm-a.pdf>

SECTION A-1: SUBCONTRACTING OPPORTUNITY

Enter the item number and description of the subcontracting opportunity you listed in SECTION 2, Item b, of the completed HSP form for which you are completing the attachment.

Item Number: _____ Description: _____

SECTION A-2: SUBCONTRACTOR SELECTION

List the subcontractor(s) you selected to perform the subcontracting opportunity you listed above in SECTION A-1. Also identify whether they are a Texas certified HUB and their Texas Vendor Identification (VID) Number or federal Employer Identification Number (EIN), the approximate dollar value of the work to be subcontracted, and the expected percentage of work to be subcontracted. When searching for Texas certified HUBs and verifying their HUB status, ensure that you use the State of Texas' Centralized Master Bidders List (CMBL) - Historically Underutilized Business (HUB) Directory Search located at <http://mycpa.cpa.state.tx.us/tpasscmlsearch/index.jsp>. HUB status code "A" signifies that the company is a Texas certified HUB.

Company Name	Texas certified HUB	Texas VID or federal EIN <small>Do not enter Social Security Numbers. If you do not know their VID / EIN, leave their VID / EIN field blank.</small>	Approximate Dollar Amount	Expected Percentage of Contract
	- Yes - No		\$	%
	- Yes - No		\$	%
	- Yes - No		\$	%
	- Yes - No		\$	%
	- Yes - No		\$	%
	- Yes - No		\$	%
	- Yes - No		\$	%
	- Yes - No		\$	%
	- Yes - No		\$	%
	- Yes - No		\$	%
	- Yes - No		\$	%
	- Yes - No		\$	%
	- Yes - No		\$	%
	- Yes - No		\$	%
	- Yes - No		\$	%
	- Yes - No		\$	%
	- Yes - No		\$	%
	- Yes - No		\$	%
	- Yes - No		\$	%
	- Yes - No		\$	%
	- Yes - No		\$	%
	- Yes - No		\$	%
	- Yes - No		\$	%
	- Yes - No		\$	%

REMINDER: As specified in SECTION 4 of the completed HSP form, if you (respondent) are awarded any portion of the requisition, you are required to provide notice as soon as practical to all the subcontractors (HUBs and Non-HUBs) of their selection as a subcontractor. The notice must specify at a minimum the contracting agency's name and its point of contact for the contract, the contract award number, the subcontracting opportunity they (the subcontractor) will perform, the approximate dollar value of the subcontracting opportunity and the expected percentage of the total contract that the subcontracting opportunity represents. A copy of the notice required by this section must also be provided to the contracting agency's point of contact for the contract no later than ten (10) working days after the contract is awarded.

HSP Good Faith Effort - Method B (Attachment B)

Rev. 2/17

Enter your company's name here: _____	Requisition #: _____
---------------------------------------	----------------------

IMPORTANT: If you responded “No” to **SECTION 2, Items c and d** of the completed HSP form, you must submit a completed “HSP Good Faith Effort - Method B (Attachment B)” for **each** of the subcontracting opportunities you listed in **SECTION 2, Item b** of the completed HSP form. You may photo-copy this page or download the form at <https://www.comptroller.texas.gov/purchasing/docs/hub-forms/hub-sbcont-plan-gfe-achm-b.pdf>.

SECTION B-1: SUBCONTRACTING OPPORTUNITY

Enter the item number and description of the subcontracting opportunity you listed in SECTION 2, Item b, of the completed HSP form for which you are completing the attachment.

Item Number: _____ Description: _____

SECTION B-2: MENTOR PROTÉGÉ PROGRAM

If respondent is participating as a Mentor in a State of Texas Mentor Protégé Program, submitting its Protégé (Protégé must be a State of Texas certified HUB) as a subcontractor to perform the subcontracting opportunity listed in **SECTION B-1**, constitutes a good faith effort to subcontract with a Texas certified HUB towards that specific portion of work.

Check the appropriate box (Yes or No) that indicates whether you will be subcontracting the portion of work you listed in SECTION B-1 to your Protégé.

- Yes (If *Yes*, continue to SECTION B-4.)
- No / Not Applicable (If *No* or *Not Applicable*, continue to SECTION B-3 and SECTION B-4.)

SECTION B-3: NOTIFICATION OF SUBCONTRACTING OPPORTUNITY

When completing this section you **MUST** comply with items **a, b, c and d**, thereby demonstrating your Good Faith Effort of having notified Texas certified HUBs and trade organizations or development centers about the subcontracting opportunity you listed in SECTION B-1. Your notice should include the scope of work, information regarding the location to review plans and specifications, bonding and insurance requirements, required qualifications, and identify a contact person. When sending notice of your subcontracting opportunity, you are encouraged to use the attached HUB Subcontracting Opportunity Notice form, which is also available online at <https://www.comptroller.texas.gov/purchasing/docs/hub-forms/HUBSubcontractingOpportunityNotificationForm.pdf>.

Retain supporting documentation (i.e., certified letter, fax, e-mail) demonstrating evidence of your good faith effort to notify the Texas certified HUBs and trade organizations or development centers. Also, be mindful that a working day is considered a normal business day of a state agency, not including weekends, federal or state holidays, or days the agency is declared closed by its executive officer. The initial day the subcontracting opportunity notice is sent/provided to the HUBs and to the trade organizations or development centers is considered to be “day zero” and does not count as one of the seven (7) working days.

- a.** Provide written notification of the subcontracting opportunity you listed in SECTION B-1, to three (3) or more Texas certified HUBs. Unless the contracting agency specified a different time period, you must allow the HUBs at least seven (7) working days to respond to the notice prior to you submitting your bid response to the contracting agency. When searching for Texas certified HUBs and verifying their HUB status, ensure that you use the State of Texas’ Centralized Master Bidders List (CMBL) - Historically Underutilized Business (HUB) Directory Search located at <http://mycpa.cpa.state.tx.us/tpasscmbsearch/index.jsp>. HUB status code “A” signifies that the company is a Texas certified HUB.
- b.** List the **three (3) Texas certified HUBs** you notified regarding the subcontracting opportunity you listed in SECTION B-1. Include the company’s Texas Vendor Identification (VID) Number, the date you sent notice to that company, and indicate whether it was responsive or non-responsive to your subcontracting opportunity notice.

Company Name	Texas VID <small>(Do not enter Social Security Numbers.)</small>	Date Notice Sent <small>(mm/dd/yyyy)</small>	Did the HUB Respond?
			- Yes - No
			- Yes - No
			- Yes - No

- c.** Provide written notification of the subcontracting opportunity you listed in SECTION B-1 to **two (2)** or more trade organizations or development centers in Texas to assist in identifying potential HUBs by disseminating the subcontracting opportunity to their members/participants. Unless the contracting agency specified a different time period, you must provide your subcontracting opportunity notice to trade organizations or development centers at least seven (7) working days prior to submitting your bid response to the contracting agency. A list of trade organizations and development centers that have expressed an interest in receiving notices of subcontracting opportunities is available on the Statewide HUB Program’s webpage at <https://www.comptroller.texas.gov/purchasing/vendor/hub/resources.php>.

- d.** List **two (2) trade organizations or development centers** you notified regarding the subcontracting opportunity you listed in SECTION B-1. Include the date when you sent notice to it and indicate if it accepted or rejected your notice.

Trade Organizations or Development Centers	Date Notice Sent <small>(mm/dd/yyyy)</small>	Was the Notice Accepted?
		- Yes - No
		- Yes - No

HSP Good Faith Effort - Method B (Attachment B) Cont.

Rev. 2/17

Enter your company's name here: _____ Requisition #: _____

SECTION B-4: SUBCONTRACTOR SELECTION

Enter the item number and description of the subcontracting opportunity you listed in **SECTION 2, Item b**, of the completed HSP form for which you are completing the attachment.

- a. Enter the item number and description of the subcontracting opportunity for which you are completing this Attachment B continuation page.
 Item Number: _____ Description: _____

- b. List the subcontractor(s) you selected to perform the subcontracting opportunity you listed in **SECTION B-1**. Also identify whether they are a Texas certified HUB and their Texas Vendor Identification (VID) Number or federal Employer Identification Number (EIN), the approximate dollar value of the work to be subcontracted, and the expected percentage of work to be subcontracted. When searching for Texas certified HUBs and verifying their HUB status, ensure that you use the State of Texas' Centralized Master Bidders List (CMBL) - Historically Underutilized Business (HUB) Directory Search located at <http://mycpa.cpa.state.tx.us/tpasscmbsearch/index.jsp>. HUB status code "A" signifies that the company is a Texas certified HUB.

Company Name	Texas certified HUB	Texas VID or federal EIN <small>Do not enter Social Security Numbers. If you do not know their VID / EIN, leave their VID / EIN field blank.</small>	Approximate Dollar Amount	Expected Percentage of Contract
	- Yes - No		\$	%
	- Yes - No		\$	%
	- Yes - No		\$	%
	- Yes - No		\$	%
	- Yes - No		\$	%
	- Yes - No		\$	%
	- Yes - No		\$	%
	- Yes - No		\$	%
	- Yes - No		\$	%
	- Yes - No		\$	%

- c. If any of the subcontractors you have selected to perform the subcontracting opportunity you listed in **SECTION B-1** is **not** a Texas certified HUB, provide written justification for your selection process (attach additional page if necessary):

REMINDER: As specified in SECTION 4 of the completed HSP form, if you (respondent) are awarded any portion of the requisition, you are required to provide notice as soon as practical to **all** the subcontractors (HUBs and Non-HUBs) of their selection as a subcontractor. The notice must specify at a minimum the contracting agency's name and its point of contact for the contract, the contract award number, the subcontracting opportunity it (the subcontractor) will perform, the approximate dollar value of the subcontracting opportunity and the expected percentage of the total contract that the subcontracting opportunity represents. A copy of the notice required by this section must also be provided to the contracting agency's point of contact for the contract no later than ten (10) working days after the contract is awarded.



HUB Subcontracting Opportunity Notification Form

In accordance with Texas Gov't Code, Chapter 2161, each state agency that considers entering into a contract with an expected value of \$100,000 or more shall, before the agency solicits bids, proposals, offers, or other applicable expressions of interest, determine whether subcontracting opportunities are probable under the contract. The state agency I have identified below in Section B has determined that subcontracting opportunities are probable under the requisition to which my company will be responding.

34 Texas Administrative Code, §20.285 requires all respondents (prime contractors) bidding on the contract to provide notice of each of their subcontracting opportunities to at least three (3) Texas certified HUBs (who work within the respective industry applicable to the subcontracting opportunity), and allow the HUBs at least seven (7) working days to respond to the notice prior to the respondent submitting its bid response to the contracting agency. In addition, at least seven (7) working days prior to submitting its bid response to the contracting agency, the respondent must provide notice of each of its subcontracting opportunities to two (2) or more trade organizations or development centers (in Texas) that serves members of groups (i.e., Asian Pacific American, Black American, Hispanic American, Native American, Woman, Service Disabled Veteran) identified in Texas Administrative Code §20.282(19)(C).

We respectfully request that vendors interested in bidding on the subcontracting opportunity scope of work identified in Section C, Item 2, reply no later than the date and time identified in Section C, Item 1. Submit your response to the point-of-contact referenced in Section A.

SECTION A: PRIME CONTRACTOR'S INFORMATION

Company Name: _____ State of Texas VID #: _____
 Point-of-Contact: _____ Phone #: _____
 E-mail Address: _____ Fax #: _____

SECTION B: CONTRACTING STATE AGENCY AND REQUISITION INFORMATION

Agency Name: _____
 Point-of-Contact: _____ Phone #: _____
 Requisition #: _____ Bid Open Date: _____
 (mm/dd/yyyy)

SECTION C: SUBCONTRACTING OPPORTUNITY RESPONSE DUE DATE, DESCRIPTION, REQUIREMENTS AND RELATED INFORMATION

1. Potential Subcontractor's Bid Response Due Date:

If you would like for our company to consider your company's bid for the subcontracting opportunity identified below in Item 2, we must receive your bid response no later than _____ on _____ Central Time Date (mm/dd/yyyy).

In accordance with 34 TAC §20.285, each notice of subcontracting opportunity shall be provided to at least three (3) Texas certified HUBs, and allow the HUBs at least seven (7) working days to respond to the notice prior to submitting our bid response to the contracting agency. In addition, at least seven (7) working days prior to us submitting our bid response to the contracting agency, we must provide notice of each of our subcontracting opportunities to two (2) or more trade organizations or development centers (in Texas) that serves members of groups (i.e., Asian Pacific American, Black American, Hispanic American, Native American, Woman, Service Disabled Veteran) identified in Texas Administrative Code, §20.282(19)(C).

(A working day is considered a normal business day of a state agency, not including weekends, federal or state holidays, or days the agency is declared closed by its executive officer. The initial day the subcontracting opportunity notice is sent/provided to the HUBs and to the trade organizations or development centers is considered to be "day zero" and does not count as one of the seven (7) working days.)

2. Subcontracting Opportunity Scope of Work:

3. Required Qualifications: - Not Applicable

4. Bonding/Insurance Requirements: - Not Applicable

5. Location to review plans/specifications: - Not Applicable

CONDITIONS OF THE CONTRACT

Uniform General Conditions
for
State of Texas Construction
Contracts

Including

Supplementary General
Conditions for
Projects Administered by the
Texas Parks and Wildlife
Department



Table of Contents

Article 1. Definitions	3
Article 2. Wage Rates and Other Laws Governing Construction	8
Article 3. General Responsibilities of Owner and Contractor	11
Article 4. Historically Underutilized Business (HUB) Subcontracting Plan.....	20
Article 5. Bonds and Insurance.....	22
Article 6. Construction Documents, Coordination Documents, and Record Documents.....	29
Article 7. Construction Safety	32
Article 8. Quality Control	34
Article 9. Construction Schedules.....	40
Article 10. Payments.....	46
Article 11. Changes	51
Article 12. Project Completion and Acceptance.....	56
Article 13. Warranty and Guarantee	61
Article 14. Suspension and Termination.....	63
Article 15. Dispute Resolution.....	67
Article 16. Miscellaneous	68

Article 1. Definitions

Unless the context clearly requires another meaning, the following terms have the meaning assigned herein.

- 1.1 *Addendum/Addenda* means formally issued written or graphic modifications and/or interpretations of the Construction Documents that may add to, delete from, clarify or correct the description and/or scope of the Work. Addenda are issued during the bidding phase of the project.
- 1.2 *Application for Payment* means Contractor's monthly partial invoice for payment that includes any portion of the Work that has been completed for which an invoice has not been submitted and performed in accordance with the requirements of the Contract Documents. The Application for Payment accurately reflects the progress of the Work, is itemized based on the Schedule of Values, bears the notarized signature of Contractor, and shall not include subcontracted items for which Contractor does not intend to pay.
- 1.3 *Application for Final Payment* means Contractor's final invoice for payment that includes any portion of the Work that has been completed for which an invoice has not been submitted, amounts owing to adjustments to the final Contract Sum resulting from approved change orders, and release of remaining Contractor's retainage.
- 1.4 *Architect/Engineer (A/E)* means a person registered as an architect pursuant to Tex. Occ. Code Ann., Ch. 1051, as a landscape architect pursuant to Tex. Occ. Code Ann., Ch. 1052, a person licensed as a professional engineer pursuant Tex. Occ. Code Ann., Ch. 1001, and/or a firm employed by Owner or Design-Build Contractor to provide professional architectural or engineering services and to exercise overall responsibility for the design of a Project or a significant portion thereof, and to perform the contract administration responsibilities set forth in the Contract.
- 1.5 ***As-Built Drawings and Specifications* means the drawing set, specifications and other materials prepared by the Contractor, in the field, that documents the changes made by the contractor. Collectively, these are also called "red-lines" or "as-builts."**
- 1.6 *Authority Having Jurisdiction* means a federal, state, local, or other regional department, or an individual such as a fire marshal, building official, electrical inspector, utility provider or other individual having statutory authority.
- 1.7 *Baseline Schedule* means the initial time schedule prepared by Contractor for Owner's information and acceptance that conveys Contractor's and Subcontractors' activities (including coordination and review activities required in the Contract Documents to be performed by A/E and ODR), durations, and sequence of work related to the entire Project to the extent required by the Contract Documents. The schedule clearly demonstrates the critical path of activities, durations and necessary predecessor conditions that drive the end date of the schedule. The Baseline Schedule shall not exceed the time limit current under the Contract Documents.

- 1.8 *Certificate of Final Completion* means the certificate issued by **TPWD that includes certification by the** A/E that documents, to the best of A/E's knowledge and understanding, Contractor's completion of all Contractor's Punchlist items and pre-final Punchlist items, final cleanup and Contractor's provision of ~~Record~~**As-Built** Documents, operations and maintenance manuals, and all other closeout documents required by the Contract Documents. **Additional documentation may be required by TPWD for consideration of the Contractor's Application for Final Payment.**
- 1.9 *Certificate of Substantial Completion* means the certificate executed by the A/E, ODR and Contractor that documents to the best of A/E's and ODR's knowledge and understanding, Contractor's sufficient completion of the work in accordance with the Contract, so as to be operational and fit for the use intended.
- 1.10 *Change Order* means a written modification of the Contract between Owner and Contractor, signed by Owner, Contractor, and A/E.
- 1.11 *Close-out Documents* mean the product brochures, submittals, product/equipment maintenance and operations instructions, manuals, and other documents/warranties, ~~record~~ **As-Built** documents, affidavit of payment, release of lien and claim, and as may be further defined, identified, and required by the Contract Documents.
- 1.12 *Contract* means the entire agreement between Owner and Contractor, including all of the Contract Documents.
- 1.13 *Contract Date* is the date when the agreement between Owner and Contractor becomes effective.
- 1.14 *Contract Documents* mean those documents identified as a component of the agreement (Contract) between Owner and Contractor. These may include, but are not limited to, Drawings; Specifications; General, Supplementary General, and Special Conditions; and all pre-bid and/or pre-proposal addenda.
- 1.15 *Contract Sum* means the total compensation payable to Contractor for completion of the Work in accordance with the terms of the Contract.
- 1.16 *Contract Time* means the period between the start date identified in the Notice to Proceed with construction and the Substantial Completion date identified in the Notice to Proceed or as subsequently amended by a Change Order.
- 1.17 *Contractor* means the individual, corporation, limited liability company, partnership, firm, or other entity contracted to perform the Work, regardless of the type of construction contract used, so that the term as used herein includes a Construction Manager-at-Risk or a Design-Build firm as well as a general or prime Contractor. The Contract Documents refer to Contractor as if singular in number.
- 1.18 *Construction Documents* mean the Drawings, Specifications, and other documents issued to build the Project. Construction Documents become part of the Contract Documents when listed in the Contract or any Change Order.

- 1.19 *Construction Manager-at-Risk*, in accordance with Tex. Gov't Code, Ch. 2166, means a sole proprietorship, partnership, corporation, or other legal entity that assumes the risk for construction, rehabilitation, alteration, or repair of a facility at the contracted price as a general contractor and provides consultation to Owner regarding construction during and after the design of the facility.
- 1.20 *Date of Commencement* means the date designated in the Notice to Proceed for Contractor to commence the Work.
- 1.21 *Day* means a calendar day unless otherwise specifically stipulated.
- 1.22 *Design-Build* means a project delivery method in which the detailed design and subsequent construction is provided through a single contract with a Design-Build firm; a team, partnership, or legal entity that includes design professionals and a builder. The Design-Build Project delivery shall be implemented in accordance with Tex. Gov't Code § 2166.2531.
- 1.23 *Drawings* mean that product of A/E which graphically depicts the Work.
- 1.24 *Final Completion* means the date determined and certified by A/E and Owner on which the Work is fully and satisfactorily complete in accordance with the Contract.
- 1.25 *Final Payment* means the last and final monetary compensation made to Contractor for any portion of the Work that has been completed and accepted for which payment has not been made, amounts owing to adjustments to the final Contract Sum resulting from approved change orders, and release of Contractor's retainage.
- 1.26 *Historically Underutilized Business (HUB)* pursuant to Tex. Gov't Code, Ch. 2161, means a business that is at least 51% owned by an Asian Pacific American, a Black American, a Hispanic American, a Native American and/or an American Woman; is an entity with its principal place of business in Texas; and has an owner residing in Texas with proportionate interest that actively participates in the control, operations, and management of the entity's affairs.
- 1.27 *Notice to Proceed (NTP)* means written document informing Contractor of the dates beginning Work and the dates anticipated for Substantial Completion.
- 1.28 *Open Item List* means a list of work activities, Punchlist items, changes or other issues that are not expected by Owner and Contractor to be complete prior to Substantial Completion.
- 1.29 *Owner* means the State of Texas, and any agency of the State of Texas, acting through the responsible entity of the State of Texas identified in the Contract as Owner. **Owner herein shall mean the Texas Parks and Wildlife Department.**
- 1.30 *Owner's Designated Representative (ODR)* means the individual assigned by Owner to act on its behalf and to undertake certain activities as specifically outlined in the Contract. ODR is the only party authorized to direct changes to the scope, cost, or

- time of the Contract.
- 1.31 *Project* means all activities necessary for realization of the Work. This includes design, contract award(s), execution of the Work itself, and fulfillment of all Contract and warranty obligations.
- 1.32 *Progress Assessment Report (PAR)* means the monthly compliance report to Owner verifying compliance with the HUB subcontracting plan (HSP).
- 1.33 *Proposed Change Order (PCO)* means a document that informs Contractor of a proposed change in the Work and appropriately describes or otherwise documents such change including Contractor's response of pricing for the proposed change.
- 1.34 *Punchlist* means a list of **minor** items of Work to be completed or corrected by Contractor after Substantial Completion. Punchlists indicate **minor** items to be finished, remaining Work to be performed, or Work that does not meet quality or quantity requirements as required in the Contract Documents.
- 1.35 *Record Documents* mean the drawing set, Specifications, and other materials ~~maintained~~ **produced by the A/E of Record** Contractor that documents all addenda, Architect's Supplemental Instructions, Change Orders, and postings and markings that record the as-constructed conditions of the Work and all changes made during construction. **The Record Documents are produced using the As-Built Drawings and Specifications as provided by the Contractor, and any As-Built documents produced by the A/E of Record during the course of the construction.**
- 1.36 *Request for Information (RFI)* means a written request by Contractor directed to A/E or ODR for a clarification of the information provided in the Contract Documents or for direction concerning information necessary to perform the Work that may be omitted from the Contract Documents.
- 1.37 *Samples* mean representative physical examples of materials, equipment, or workmanship used to confirm compliance with requirements and/or to establish standards for use in execution of the Work.
- 1.38 *Schedule of Values* means the detailed breakdown of the cost of the materials, labor, and equipment necessary to accomplish the Work as described in the Contract Documents, submitted by Contractor for approval by Owner and A/E.
- 1.39 *Shop Drawings* mean the drawings, diagrams, illustrations, schedules, performance charts, brochures, and other data prepared by Contractor or its agents which detail a portion of the Work.
- 1.40 *Site* means the geographical area of the location of the Work.
- 1.41 *Special Conditions* mean the documents containing terms and conditions which may be unique to the Project. Special Conditions are a part of the Contract Documents and have precedence over the Uniform General Conditions and Supplementary General Conditions.

- 1.42 *Specifications* mean the written product of A/E that establishes the quality and/or performance of products utilized in the Work and processes to be used, including testing and verification for producing the Work.
- 1.43 *Subcontractor* means a business entity that enters into an agreement with Contractor to perform part of the Work or to provide services, materials, or equipment for use in the Work.
- 1.44 *Submittal Register* means a list provided by Contractor of all items to be furnished for review and approval by A/E and Owner and as identified in the Contract Documents including anticipated sequence and submittal dates.
- 1.45 *Substantial Completion* means the date determined and certified by Contractor, A/E, and Owner when the Work, or a designated portion thereof, is sufficiently complete, in accordance with the Contract, so as to be operational and fit for the use intended.
- 1.46 *Supplementary General Conditions* mean procedures and requirements that modify the Uniform General Conditions. Supplementary General Conditions, when used, have precedence over the Uniform General Conditions. ***Texas Parks and Wildlife Department has adopted Uniform Supplementary General Conditions that apply to all TPWD construction projects. TPWD Uniform Supplementary General Conditions are indicated by the bold and italicized typeface shown here.***
- 1.47 *Unit Price Work* means the Work, or a portion of the Work, paid for based on incremental units of measurement.
- 1.48 *Unilateral Change Order (ULCO)* means a Change Order issued by Owner without the complete agreement of Contractor, as to cost and/or time.
- 1.49 *Work* means the administration, procurement, materials, equipment, construction and all services necessary for Contractor, and/or its agents, to fulfill Contractor's obligations under the Contract.
- 1.50 *Work Progress Schedule* means the continually updated time schedule prepared and monitored by Contractor that accurately indicates all necessary appropriate revisions as required by the conditions of the Work and the Project while maintaining a concise comparison to the Baseline Schedule.

Article 2. Wage Rates and Other Laws Governing Construction

- 2.1 Environmental Regulations. Contractor shall conduct activities in compliance with applicable laws and regulations and other requirements of the Contract relating to the environment and its protection at all times. Unless otherwise specifically determined, Owner is responsible for obtaining and maintaining permits related to stormwater run-off. Contractor shall conduct operations consistent with stormwater run-off permit conditions. Contractor is responsible for all items it brings to the Site, including hazardous materials, and all such items brought to the Site by its Subcontractors and suppliers, or by other entities subject to direction of Contractor. Contractor shall not incorporate hazardous materials into the Work without prior approval of Owner, and shall provide an affidavit attesting to such in association with request for Substantial Completion inspection.
- 2.2 Wage Rates. Contractor shall not pay less than the wage scale of the various classes of labor as shown on the prevailing wage schedule provided by Owner in the bid or proposal specifications. The specified wage rates are minimum rates only. Owner is not bound to pay any claims for additional compensation made by any Contractor because the Contractor pays wages in excess of the applicable minimum rate contained in the Contract. The prevailing wage schedule is not a representation that qualified labor adequate to perform the Work is available locally at the prevailing wage rates.
- 2.2.1 Notification to Workers. Contractor shall post the prevailing wage schedule in a place conspicuous to all workers on the Project Site When requested by Owner, Contractor shall furnish evidence of compliance with the Texas Prevailing Wage Law and the addresses of all workers.
- 2.2.1.1 Pursuant to Tex. Gov't Code § 2258.024, Contractor shall keep, on site, true and accurate records showing the name and occupation of each worker employed by the Contractor or subcontractors and the actual per diem wages paid to each worker. The record shall be open to inspection by the ODR and their agents at all reasonable hours for the duration of the contract.
- 2.2.1.2 With each application for progress payment, Contractor shall make available upon request certified payroll records, including from subcontractors of any tier level, on Form WH-347 as promulgated by the U.S. Department of Labor, as may be revised from time to time and in unlocked and unprotected Excel format, along with copies of any and all Contract Documents between Contractor and any Subcontractors. Pursuant to Tex. Penal Code §§ 37.02 and 37.10, Employees of Contractor and subcontractors, including all tier levels, shall be subject to prosecution for submitting certified payroll records that contain materially false information.
- 2.2.1.3 The prevailing wage schedule is determined by Owner in compliance

with Tex. Gov't Code, Ch. 2258. Should Contractor at any time become aware that a particular skill or trade not reflected on Owner's prevailing wage schedule will be or is being employed in the Work, whether by Contractor or by Subcontractor, Contractor shall promptly inform ODR of the proposed wage to be paid for the skill along with a justification for same and ODR shall promptly concur with or reject the proposed wage and classification.

2.2.1.4 Contractor is responsible for determining the most appropriate wage for a particular skill in relation to similar skills or trades identified on the prevailing wage schedule. In no case, shall any worker be paid less than the wage indicated for laborers.

2.2.1.5 Pursuant to Tex. Labor Code § 214.008, Misclassification of Workers; Penalty. The Owner requires Contractor and all subcontractors properly classify individuals as Employees or Independent Contractors.

2.2.2 Penalty for Violation. Contractor, and any Subcontractor, will pay to the State a penalty of sixty dollars (\$60) for each worker employed for each day, or portion thereof, that the worker is paid less than the wage rates stipulated in the prevailing wage schedule

2.2.3 Complaints of Violations.

2.2.3.1 Owner's Determination of Good Cause. Upon receipt of information concerning a violation, Owner will conduct an investigation in accordance with Tex. Gov't Code, Ch. 2258 and make an initial determination as to whether good cause exists that a violation occurred. Upon making a good cause finding, Owner will retain the full amounts claimed by the claimant or claimants as the difference between wages paid and wages due under the prevailing wage schedule and any supplements thereto, together with the applicable penalties in accordance with Tex. Gov't Code § 2258.023, such amounts being subtracted from successive progress payments pending a final decision on the violation.

2.2.3.2 No Extension of Time. If Owner's determination proves valid that good cause existed to believe a violation had occurred, Contractor is not entitled to an extension of time for any delay arising directly or indirectly from the arbitration procedures.

2.2.3.3 Cooperation with Owner's Investigation. Contractor shall cooperate with Owner during any investigations hereunder. Such cooperation shall include, but not necessarily be limited to, timely providing the information and/or documentation requested by Owner, which may include certified payroll records on Form WH-347 as promulgated by the U.S. Department of Labor, as may be revised from time to time and in unlocked and unprotected Excel format; and copies of any and

all Contract Documents between Contractor and any Subcontractors.

2.2.3.4 Notification to Owner. In the event Contractor or Subcontractor elect to appeal an initial determination made pursuant to Paragraph 2.2.3.1, the Contractor and/or Subcontractor, as applicable, shall deliver notice thereof to Owner.

2.3 Venue for Suits. The venue for any suit arising from the Contract will be in a court of competent jurisdiction in Travis County, Texas, or as may otherwise be designated in the Supplementary General Conditions.

2.4 Licensing of Trades. Contractor shall comply with all applicable provisions of State law related to license requirements for skilled tradesmen, contractors, suppliers and or laborers, as necessary to accomplish the Work. In the event Contractor, or one of its Subcontractors, loses its license during the term of performance of the Contract, Contractor shall promptly hire or contract with a licensed provider of the service at no additional cost to Owner.

2.5 Royalties, Patents, and Copyrights. Contractor shall pay all royalties and license fees, defend suits or claims for infringement of copyrights and patent rights, and shall hold Owner harmless from loss on account thereof, but shall not be responsible for such defense or loss when a particular design, process or product of a particular manufacturer or manufacturers is required by the Contract Documents, or where the copyright violations are contained in Drawings, Specifications or other documents prepared by Owner or A/E. However, if Contractor has reason to believe that the required design, process, or product is an infringement of a copyright or a patent, Contractor shall be responsible for such loss unless such information is promptly furnished to A/E.

2.6 State Sales and Use Taxes. Owner qualifies for exemption from certain State and local sales and use taxes pursuant to the provisions of Tex. Tax Code, Ch. 151. Upon request from Contractor, Owner shall furnish evidence of tax exempt status. Contractor may claim exemption from payment of certain applicable State taxes by complying with such procedures as prescribed by the State Comptroller of Public Accounts. Owner acknowledges not all items qualify for exemption. Owner is not obligated to reimburse Contractor for taxes paid on items that qualify for tax exemption.

Article 3. General Responsibilities of Owner and Contractor

- 3.1 Owner's General Responsibilities. Owner is the entity identified as such in the Contract and referred to throughout the Contract Documents as if singular in number.
- 3.1.1 Preconstruction Conference. Prior to, or concurrent with, the issuance of Notice to Proceed with construction, a conference will be convened for attendance by Owner, Contractor, A/E and appropriate Subcontractors. The purpose of the conference is to establish a working understanding among the parties as to the Work, the operational conditions at the Project Site, and general administration of the Project. Topics include communications, schedules, procedures for handling Shop Drawings and other submittals, processing Applications for Payment, maintaining required records and all other matters of importance to the administration of the Project and effective communications between the Project team members.
- 3.1.2 Owner's Designated Representative. Prior to the start of construction, Owner will identify Owner's Designated Representative (ODR), who has the express authority to act and bind Owner to the extent and for the purposes described in the various Articles of the Contract, including responsibilities for general administration of the Contract.
- 3.1.2.1 Unless otherwise specifically defined elsewhere in the Contract Documents, ODR is the single point of contact between Owner and Contractor. Notice to ODR, unless otherwise noted, constitutes notice to Owner under the Contract.
- 3.1.2.2 All directives on behalf of Owner will be conveyed to Contractor and A/E by ODR in writing.
- 3.1.2.3 Owner will furnish or cause to be furnished, free of charge, the number of complete sets of the Drawings, Specifications, and addenda as provided in the Supplementary General Conditions or Special Conditions.
- 3.1.2.4 The ODR will establish the protocol for planning, scheduling and documenting progress meetings with provisions for absence of various project team members that have a key role in these duties.
- 3.1.3 Owner Supplied Materials and Information.
- 3.1.3.1 Owner will furnish to Contractor those surveys describing the physical characteristics, legal description, limitations of the Site, Site utility locations, and other information used in the preparation of the Contract Documents.
- 3.1.3.2 Owner will provide information, equipment, or services under

Owner's control to Contractor with reasonable promptness.

- 3.1.4 Availability of Lands. Owner will furnish, as indicated in the Contract, all required rights to use the lands upon which the Work occurs. This includes rights-of-way and easements for access and such other lands that are designated for use by Contractor. Contractor shall comply with all Owner identified encumbrances or restrictions specifically related to use of lands so furnished. Owner will obtain and pay for easements for permanent structures or permanent changes in existing facilities.
- 3.1.5 Limitation on Owner's Duties.
 - 3.1.5.1 Owner will not supervise, direct, control or have authority over or be responsible for Contractor's means, methods, technologies, sequences or procedures of construction or the safety precautions and programs incident thereto. Owner is not responsible for any failure of Contractor to comply with laws and regulations applicable to the Work. Owner is not responsible for the failure of Contractor to perform or furnish the Work in accordance with the Contract Documents. Except as provided in Section 2.5, Owner is not responsible for the acts or omissions of Contractor, or any of its Subcontractors, suppliers or of any other person or organization performing or furnishing any of the Work on behalf of Contractor.
 - 3.1.5.2 Owner will not take any action in contravention of a design decision made by A/E in preparation of the Contract Documents, when such actions are in conflict with statutes under which A/E is licensed for the protection of the public health and safety.
- 3.2 Role of Architect/Engineer. Unless specified otherwise in the Contract between Owner and Contractor, A/E shall provide general administration services for Owner during the construction phase of the project. Written correspondence, requests for information, and Shop Drawings/submittals shall be directed to A/E for action. A/E has the authority to act on behalf of Owner to the extent provided in the Contract Documents, unless otherwise modified by written instrument, which will be furnished to Contractor by ODR, upon request.
 - 3.2.1 Site Visits.
 - 3.2.1.1 A/E will make visits to the Site at intervals as provided in the A/E's Contract with Owner, to observe the progress and the quality of the various aspects of Contractor's executed Work and report findings to Owner.
 - 3.2.1.2 A/E has the authority to interpret Contract Documents and inspect the Work for compliance and conformance with the Contract. Except as referenced in Paragraph 3.1.5.2, Owner retains the sole authority to accept or reject Work and issue direction for correction,

removal, or replacement of Work.

- 3.2.2 Clarifications and Interpretations. It may be determined that clarifications or interpretations of the Contract Documents are necessary. Upon direction by ODR, such clarifications or interpretations will be provided by A/E consistent with the intent of the Contract Documents. A/E will issue these clarifications with reasonable promptness to Contractor as A/E's supplemental instruction ("ASI") or similar instrument. If Contractor believes that such clarification or interpretation justifies an adjustment in the Contract Sum or the Contract Time, Contractor shall so notify Owner in accordance with the provisions of Article 11.
- 3.2.3 Limitations on Architect/Engineer Authority. A/E is not responsible for:
- 3.2.3.1 Contractor's means, methods, techniques, sequences, procedures, safety, or programs incident to the Project, nor will A/E supervise, direct, control or have authority over the same;
 - 3.2.3.2 The failure of Contractor to comply with laws and regulations applicable to the furnishing or performing the Work;
 - 3.2.3.3 Contractor's failure to perform or furnish the Work in accordance with the Contract Documents; or
 - 3.2.3.4 Acts or omissions of Contractor, or of any other person or organization performing or furnishing any of the Work.
- 3.3 Contractor's General Responsibilities. Contractor is solely responsible for implementing the Work in full compliance with all applicable laws and the Contract Documents and shall supervise and direct the Work using the best skill and attention to assure that each element of the Work conforms to the Contract requirements. Contractor is solely responsible for all construction means, methods, techniques, safety, sequences, coordination, procedures and protection of the installed work as part of the contract until substantial completion of the project. Contractor remains responsible for the care and protection of materials and Work in the areas where punch list items are completed until Final Completion.
- 3.3.1 Project Administration. Contractor shall provide Project administration for all Subcontractors, vendors, suppliers, and others involved in implementing the Work and shall coordinate administration efforts with those of A/E and ODR in accordance with these general conditions and other provisions of the Contract, and as outlined in the preconstruction conference. Contractor's Project Administration includes periodic daily reporting on weather, work progress, labor, materials, equipment, obstructions to prosecution of the work, accidents and injuries in accordance with the Contract and transmitted no less frequently than on a weekly basis.
- 3.3.2 Contractor's Management Personnel. Contractor shall employ a competent person or persons who will be present at the Project Site during the progress

of the Work to supervise or oversee the work. The competent persons are subject to the approval of ODR ***through the submittal process stated in Owner's Special Conditions***. Contractor shall not change approved staff during the course of the project without the written approval of ODR unless the staff member leaves the employment of Contractor. Contractor shall provide additional quality control, safety and other staff as stated in the Supplementary General Conditions.

- 3.3.3 Labor. Contractor shall provide competent, suitably qualified personnel to survey, lay-out, and construct the Work as required by the Contract Documents and maintain good discipline and order at the Site at all times.
- 3.3.4 Services, Materials, and Equipment. Unless otherwise specified, Contractor shall provide and assume full responsibility for all services, materials, equipment, labor, transportation, construction equipment and machinery, tools, appliances, fuel, power, light, heat, telephone, water, sanitary facilities, temporary facilities, and all other facilities, incidentals, and services necessary for the construction, performance, testing, start-up, inspection and completion of the Work.
- 3.3.5 Contractor General Responsibility. For Owner furnished equipment or material that will be in the care, custody, and control of Contractor, Contractor is responsible for damage or loss. Owner shall deliver to Contractor a complete list and respective values of such materials or equipment and make an equitable adjustment to the contract amount for any increase in cost of Builder's Risk insurance.
- 3.3.6 Non-Compliant Work. Should A/E and/or ODR identify Work as non-compliant with the Contract Documents, A/E and/or ODR shall communicate the finding to Contractor, and Contractor shall correct such Work at no additional cost to the Owner. The approval of Work by either A/E or ODR does not relieve Contractor from the obligation to comply with all requirements of the Contract Documents.
- 3.3.7 Subcontractors. Contractor shall not employ any Subcontractor, supplier or other person or organization, whether initially or as a substitute, against whom Owner shall have reasonable objection. Owner will communicate such objections in writing within ten (10) days of receipt of Contractor's intent to use such Subcontractor, supplier, or other person or organization. Contractor is not required to employ any Subcontractor, supplier or other person or organization to furnish any of the work to whom Contractor has reasonable objection. Contractor shall not substitute Subcontractors without the acceptance of Owner. Pursuant to Tex. Gov't Code § 2269.256(b), if the Contractor reviews, evaluates and recommends that the Owner accept a bid or proposal from a Subcontractor but the Owner requires another bid or proposal to be accepted, Owner shall compensate the Contractor by a change in price, time or guaranteed maximum cost for any additional cost or risk the Contractor will incur because of Owner's requirement to select another bid or proposal rather than the one recommended.

- 3.3.7.1 All Subcontracts and supply contracts shall be consistent with and bind the Subcontractors and suppliers to the terms and conditions of the Contract Documents including provisions of the Contract between Contractor and Owner.
- 3.3.7.2 Contractor shall be solely responsible for scheduling and coordinating the Work of Subcontractors, suppliers and other persons and organizations performing or furnishing any of the Work under a direct or indirect contract with Contractor. Require all Subcontractors, suppliers and such other persons and organizations performing or furnishing any of the Work to communicate with Owner only through Contractor. Contractor shall furnish to Owner a copy, at Owner's request, of each first-tier subcontract promptly after its execution. Contractor agrees that Owner has no obligation to review or approve the content of such contracts and that providing Owner such copies in no way relieves Contractor of any of the terms and conditions of the Contract, including, without limitation, any provisions of the Contract which require the Subcontractor to be bound to Contractor in the same manner in which Contractor is bound to Owner.
- 3.3.8 Continuing the Work. Contractor shall carry on the Work and adhere to the progress schedule during all disputes, disagreements, or alternative resolution processes with Owner. Contractor shall not delay or postpone any Work because of pending unresolved disputes, disagreements or alternative resolution processes, except as Owner and Contractor may agree in writing.
- 3.3.9 Cleaning. Contractor shall at all times, keep the Site and the Work clean and free from accumulation of waste materials or rubbish caused by the construction activities under the Contract. Contractor shall ensure that the entire Project is thoroughly cleaned prior to requesting Substantial Completion inspection and, again, upon completion of the Project prior to the final inspection.
- 3.3.10 Acts and Omissions of Contractor, its Subcontractors, and Employees. Contractor shall be responsible for acts and omissions of his employees and all its Subcontractors, their agents and employees. Owner may, in writing, require Contractor to remove from the Project any of Contractor's or its Subcontractor's employees whom ODR finds to be careless, incompetent, unsafe, uncooperative, disruptive, or otherwise objectionable.
- 3.3.11 Acts or Omissions. Contractor shall indemnify and hold harmless the State of Texas and Customers, AND/OR THEIR OFFICERS, AGENTS, EMPLOYEES, REPRESENTATIVES, CONTRACTORS, ASSIGNEES, AND/OR DESIGNEES FROM ANY AND ALL LIABILITY, ACTIONS, CLAIMS, DEMANDS, OR SUITS, AND ALL RELATED COSTS, ATTORNEY FEES, AND EXPENSES arising out of, or resulting from any acts or omissions of Contractor or its agents, employees, subcontractors, Order

Fulfillers, or suppliers of subcontractors in the execution or performance of the Contract and any Purchase Orders issued under the Contract. THE DEFENSE SHALL BE COORDINATED BY CONTRACTOR WITH THE OFFICE OF THE ATTORNEY GENERAL WHEN TEXAS STATE AGENCIES ARE NAMED DEFENDANTS IN ANY LAWSUIT AND CONTRACTOR MAY NOT AGREE TO ANY SETTLEMENT WITHOUT FIRST OBTAINING THE CONCURRENCE FROM THE OFFICE OF THE ATTORNEY GENERAL. CONTRACTOR AND OWNER AGREE TO FURNISH TIMELY WRITTEN NOTICE TO EACH OTHER OF ANY SUCH CLAIM.

3.3.12 Infringements.

3.3.12.1 Contractor shall indemnify and hold harmless the State of Texas and Customers, AND/OR THEIR EMPLOYEES, AGENTS, REPRESENTATIVES, CONTRACTORS, ASSIGNEES, AND/OR DESIGNEES from any and all third party claims involving infringement of United States patents, copyrights, trade and service marks, and any other intellectual or intangible property rights in connection with the PERFORMANCES OR ACTIONS OF CONTRACTOR PURSUANT TO THIS CONTRACT. CONTRACTOR AND THE CUSTOMER AGREE TO FURNISH TIMELY WRITTEN NOTICE TO EACH OTHER OF ANY SUCH CLAIM. CONTRACTOR SHALL BE LIABLE TO PAY ALL COSTS OF DEFENSE INCLUDING ATTORNEYS' FEES. THE DEFENSE SHALL BE COORDINATED BY CONTRACTOR WITH THE OFFICE OF THE ATTORNEY GENERAL WHEN TEXAS STATE AGENCIES ARE NAMED DEFENDANTS IN ANY LAWSUIT AND CONTRACTOR MAY NOT AGREE TO ANY SETTLEMENT WITHOUT FIRST OBTAINING THE CONCURRENCE FROM THE OFFICE OF THE ATTORNEY GENERAL.

3.3.12.2 Contractor shall have no liability under this section if the alleged infringement is caused in whole or in part by: (i) use of the product or service for a purpose or in a manner for which the product or service was not designed, (ii) any modification made to the product without Contractor's written approval, (iii) any modifications made to the product by Contractor pursuant to Customer's specific instructions, (iv) any intellectual property right owned by or licensed to Customer, or (v) any use of the product or service by Customer that is not in conformity with the terms of any applicable license agreement.

3.3.12.3 If Contractor becomes aware of an actual or potential claim, or Customer provides Contractor with notice of an actual or potential claim, Contractor may (or in the case of an injunction against Customer, shall), at Contractor's sole option and expense; (i) procure for the Customer the right to continue to use the affected portion of the product or service, or (ii) modify or replace the affected portion of the product or service with functionally equivalent or superior product

or service so that Customer's use is non-infringing.

3.3.12.4 Taxes/Workers' Compensation/Unemployment Insurance-Including Indemnity.

3.3.12.4.1 CONTRACTOR AGREES AND ACKNOWLEDGES THAT DURING THE EXISTENCE OF THIS CONTRACT, CONTRACTOR SHALL BE ENTIRELY RESPONSIBLE FOR THE LIABILITY AND PAYMENT OF CONTRACTOR'S AND CONTRACTOR'S EMPLOYEES' TAXES OF WHATEVER KIND, ARISING OUT OF THE PERFORMANCES IN THIS CONTRACT. CONTRACTOR AGREES TO COMPLY WITH ALL STATE AND FEDERAL LAWS APPLICABLE TO ANY SUCH PERSONS, INCLUDING LAWS REGARDING WAGES, TAXES, INSURANCE, AND WORKERS' COMPENSATION. THE CUSTOMER AND/OR THE STATE SHALL NOT BE LIABLE TO CONTRACTOR, ITS EMPLOYEES, AGENTS, OR OTHERS FOR THE PAYMENT OF TAXES OR THE PROVISION OF UNEMPLOYMENT INSURANCE AND/OR WORKERS' COMPENSATION OR ANY BENEFIT AVAILABLE TO A STATE EMPLOYEE OR EMPLOYEE OF ANOTHER GOVERNMENTAL ENTITY CUSTOMER.

3.3.12.4.1 CONTRACTOR AGREES TO INDEMNIFY AND HOLD HARMLESS OWNER, THE STATE OF TEXAS AND/OR THEIR EMPLOYEES, AGENTS, REPRESENTATIVES, CONTRACTORS, AND/OR ASSIGNEES FROM ANY AND ALL LIABILITY, ACTIONS, CLAIMS, DEMANDS, OR SUITS, AND ALL RELATED COSTS, ATTORNEYS' FEES, AND EXPENSES, RELATING TO TAX LIABILITY, UNEMPLOYMENT INSURANCE AND/OR WORKERS' COMPENSATION IN ITS PERFORMANCE UNDER THIS CONTRACT. CONTRACTOR SHALL BE LIABLE TO PAY ALL COSTS OF DEFENSE INCLUDING ATTORNEYS' FEES. THE DEFENSE SHALL BE COORDINATED BY CONTRACTOR WITH THE OFFICE OF THE ATTORNEY GENERAL WHEN TEXAS STATE AGENCIES ARE NAMED DEFENDANTS IN ANY LAWSUIT

AND VENDOR MAY NOT AGREE TO ANY SETTLEMENT WITHOUT FIRST OBTAINING THE CONCURRENCE FROM THE OFFICE OF THE ATTORNEY GENERAL. CONTRACTOR AND OWNER AGREE TO FURNISH TIMELY WRITTEN NOTICE TO EACH OTHER OF ANY SUCH CLAIM.

- 3.3.12.5 The provisions of this indemnification are solely for the benefit of the parties hereto and not intended to create or grant any rights, contractual or otherwise, to any other person or entity.
- 3.3.12.6 Contractor shall promptly advise Owner in writing of any claim or demand against Owner or against Contractor which involves Owner and known to Contractor and related to or arising out of Contractor's activities under this Contract.
- 3.3.13 Ancillary Areas. Operate and maintain operations and associated storage areas at the site of the Work in accordance with the following:
- 3.3.13.1 Confine all Contractor operations, including storage of materials and employee parking upon the Site of Work, to areas designated by Owner.
- 3.3.13.2 Contractor may erect, at its own expense, temporary buildings that will remain its property. Remove such buildings and associated utility service lines upon completion of the Work, unless Contractor requests and Owner provides written consent that it may abandon such buildings and utilities in place.
- 3.3.13.3 Use only established roadways or construct and use such temporary roadways as may be authorized by Owner. Do not allow load limits of vehicles to exceed the limits prescribed by appropriate regulations or law. Provide protection to road surfaces, curbs, sidewalks, trees, shrubbery, sprinkler systems, drainage structures and other like existing improvements to prevent damage and repair any damage thereto at the expense of Contractor.
- 3.3.13.4 Owner may restrict Contractor's entry to the Site to specifically assigned entrances and routes.
- 3.3.14 Separate Contracts. Owner reserves the right to award other contracts in connection with other portions of the Project under these same or substantially similar contract conditions, including those portions related to insurance and waiver of subrogation. Owner reserves the right to perform operations related to the Project with Owner's own forces.
- 3.3.15 Under a system of separate contracts, the conditions described herein continue to apply except as may be amended by change order.

- 3.3.16 Contractor shall cooperate with other contractors or forces employed on the Project by Owner, including providing access to Site and Project information as requested.
- 3.3.17 Owner shall be reimbursed by Contractor for costs incurred by Owner which are payable to a separate contractor because of delays, improperly timed activities, or defective construction by Contractor. Owner will equitably adjust the Contract by Change Order for costs incurred by Contractor because of delays, improperly timed activities, damage to the Work or defective construction by a separate contractor.

Article 4. Historically Underutilized Business (HUB) Subcontracting Plan

- 4.1 General Description. The purpose of the Historically Underutilized Business (HUB) program is to promote equal business opportunities for economically disadvantaged persons (as defined by Tex. Gov't Code, Ch. 2161) to contract with the State of Texas in accordance with the goals specified in the State of Texas Disparity Study. The HUB program annual procurement utilization goals are defined in 34 T.A.C. § 20.13(b).
- 4.1.1 State agencies are required by statute to make a good faith effort to assist HUBs in participating in contract awards issued by the State. 34 T.A.C. § 20.13(b) outlines the State's policy to encourage the utilization of HUBs in State contracting opportunities through race, ethnic and gender neutral means.
- 4.1.2 A Contractor who contracts with the State in an amount of \$100,000 or greater is required to make a good faith effort to award subcontracts to HUBs in accordance with 34 T.A.C. § 20.14(a)(2)(A) by submitting a HUB subcontracting plan within twenty-four (24) hours after the bid or response is due and complying with the HUB subcontracting plan after it is accepted by Owner and during the term of the Contract. ***Unless stated otherwise in the contract documents, the HUB subcontracting plan shall be submitted with the bid or response on or before the specified due date and time for the bid or response.***
- 4.2 Compliance with Approved HUB Subcontracting Plan. Contractor, having been awarded this Contract in part by complying with the HUB program statute and rules, hereby covenants to continue to comply with the HUB program as follows:
- 4.2.1 Prior to adding or substituting a Subcontractor, promptly notify Owner in the event a change is required for any reason to the accepted HUB subcontracting plan.
- 4.2.2 Conduct the good-faith effort activities required and provide Owner with necessary documentation to justify approval of a change to the approved HUB subcontracting plan.
- 4.2.3 Cooperate in the execution of a Change Order or such other approval of the change in the HUB subcontracting plans as Contractor and Owner may agree to.
- 4.2.4 Maintain and make available to Owner upon request business records documenting compliance with the accepted HUB subcontracting plan.
- 4.2.5 Upon receipt of payment for performance of Work, submit to Owner a compliance report, in the format required by Owner that demonstrates Contractor's performance of the HUB subcontracting plan. ***TPWD requires submission of a copy of the compliance report with the Application for Payment for work performed.***

- 4.2.5.1 Progress Assessment Report (PAR): monthly compliance reports to Owner (contracting agency), verifying their compliance with the HUB subcontracting plan, including the use/expenditures they have made to Subcontractors. The PAR is available at in the Index Forms Library on the Facilities Design & Construction page of the Texas Facilities Commission website. (<http://www.window.state.tx.us/procurement/prog/hub/hub-forms/progressassessmentrpt.xls>). **Contractor shall submit a PAR to TPWD HUB Administration no later than the 5th day of the month. Contractor shall submit a copy of the current month's PAR with the Application for Payment.**
- 4.2.6 Promptly and accurately explain and provide supplemental information to Owner to assist in Owner's investigation of Contractor's good-faith effort to fulfill the HUB subcontracting plan and the requirements under 34 T.A.C. § 20.14(a)(1).
- 4.3 Failure to Demonstrate Good-Faith Effort. Upon a determination by Owner that Contractor has failed to demonstrate a good-faith effort to fulfill the HUB subcontracting plan or any Contract covenant detailed above, Owner may, in addition to all other remedies available to it, report the failure to perform to the Comptroller of Public Accounts, Texas Procurement and Support Services Division, Historically Underutilized Business Program and may bar Contractor from future contracting opportunities with Owner.

Article 5. Bonds and Insurance

- 5.1 Construction Bonds. Contractor is required to tender to Owner, prior to commencing the Work, performance and payment bonds, as required by Tex. Gov't Code, Ch. 2253. On Construction Manager-at-Risk and Design-Build Projects the Owner shall require a security bond, as described in Subsection 5.1.2 below.
- 5.1.1 Bond Requirements. Each bond shall be executed by a corporate surety or sureties authorized to do business in the State of Texas and acceptable to Owner, on Owner's form, and in compliance with the relevant provisions of the Texas Insurance Code. If any bond is for more than ten (10) percent of the surety's capital and surplus, Owner may require certification that the company has reinsured the excess portion with one or more reinsurers authorized to do business in the State. A reinsurer may not reinsure for more than ten (10) percent of its capital and surplus. If a surety upon a bond loses its authority to do business in the State, Contractor shall, within thirty (30) days after such loss, furnish a replacement bond at no added cost to Owner.
- 5.1.1.1 A Performance bond is required if the Contract Sum is in excess of \$100,000. The performance bond is solely for the protection of Owner. The performance bond is to be for the Contract Sum to guarantee the faithful performance of the Work in accordance with the Contract Documents. The form of the bond shall be approved by the Office of the Attorney General of Texas. The performance bond shall be effective through Contractor's warranty period.
- 5.1.1.2 A Payment bond is required if the Contract price is in excess of \$25,000. The payment bond is to be for the Contract Sum and is payable to Owner solely for the protection and use of payment bond beneficiaries. The form of the bond shall be approved by the Office of the Attorney General of Texas.
- 5.1.2 Security Bond. The security bond provides protection to Owner if Contractor presents an acceptable guaranteed maximum price ("GMP") to Owner and 1) fails to execute the GMP; or 2) fails to deliver the required payment and performance bonds within the time period stated below.
- 5.1.3 When Bonds Are Due.
- 5.1.3.1 Security bonds are due within ten (10) days of signing a Construction Manager-at-Risk or Design-Build Contract, ***unless stated otherwise in the contract documents.***
- 5.1.3.2 Payment and performance bonds are due within ten (10) days of Contractor's receipt of a fully executed GMP on a Construction Manager-at-Risk project or the Contract Sum for a Design-Build project, or within ten (10) days of Contractor's receipt of a fully executed Contract on competitively bid or competitive sealed

proposal projects.

- 5.1.4 Power of Attorney. Each bond shall be accompanied by a valid power of attorney (issued by the surety company and attached, signed and sealed with the corporate embossed seal, to the bond) authorizing the attorney-in-fact who signs the bond to commit the company to the terms of the bond, and stating any limit in the amount for which the attorney can issue a single bond.
 - 5.1.5 Bond Indemnification. The process of requiring and accepting bonds and making claims there under shall be conducted in compliance with Tex. Gov't Code, Ch. 2253. IF FOR ANY REASON A STATUTORY PAYMENT OR PERFORMANCE BOND IS NOT HONORED BY THE SURETY, CONTRACTOR SHALL FULLY INDEMNIFY AND HOLD OWNER HARMLESS OF AND FROM ANY COSTS, LOSSES, OBLIGATIONS OR LIABILITIES IT INCURS AS A RESULT.
 - 5.1.6 Furnishing Bond Information. Owner shall furnish certified copies of the payment bond and the related Contract to any qualified person seeking copies who complies with Tex. Gov't Code § 2253.026.
 - 5.1.7 Claims on Payment Bonds. Claims on payment bonds must be sent directly to Contractor and his surety in accordance with Tex. Gov't Code § 2253.041. All payment bond claimants are cautioned that no lien exists on the funds unpaid to Contractor on such Contract, and that reliance on notices sent to Owner may result in loss of their rights against Contractor and/or his surety. Owner is not responsible in any manner to a claimant for collection of unpaid bills, and accepts no such responsibility because of any representation by any agent or employee.
 - 5.1.8 Payment Claims when Payment Bond not Required. The rights of Subcontractors regarding payment are governed by Tex. Prop. Code §§ 53.231 – 53.239 when the value of the Contract between Owner and Contractor is less than \$25,000.00. These provisions set out the requirements for filing a valid lien on funds unpaid to Contractor as of the time of filing the claim, actions necessary to release the lien and satisfaction of such claim.
 - 5.1.9 Sureties. A surety shall be listed on the US Department of the Treasury's Listing of Approved Sureties maintained by the Bureau of Financial Management Service (FMS), www.fms.treas.gov/c570, stating companies holding Certificates of Authority as acceptable sureties on Federal bonds and acceptable reinsuring companies (FMS Circular 570).
- 5.2 Insurance Requirements. Contractor shall carry insurance in the types and amounts indicated in this Article for the duration of the Contract. The insurance shall be evidenced by delivery to Owner of certificates of insurance executed by the insurer or its authorized agent stating coverages, limits, expiration dates and compliance with all applicable required provisions. Upon request, Owner, and/or its agents, shall be entitled to receive without expense, copies of the policies and all endorsements. Contractor shall update all expired policies prior to submission for monthly payment.

Failure to update policies shall be reason for withholding of payment until renewal is provided to Owner.

- 5.2.1 Contractor shall provide and maintain all insurance coverage with the minimum amounts described below until the end of the warranty period unless otherwise stated in Supplementary General Conditions or Special Conditions. Failure to maintain insurance coverage, as required, is grounds for suspension of Work for cause pursuant to Article 14.
- 5.2.2 Contractor shall deliver to Owner true and complete copies of certificates and corresponding policy endorsements prior to the issuance of any Notice to Proceed.
- 5.2.3 Failure of Owner to demand such certificates or other evidence of Contractor's full compliance with these insurance requirements or failure of Owner to identify a deficiency in compliance from the evidence provided shall not be construed as a waiver of Contractor's obligation to maintain such insurance.
- 5.2.4 The insurance and insurance limits required herein shall not be deemed as a limitation on Contractor's liability under the indemnities granted to Owner in the Contract Documents.
- 5.2.5 The insurance coverage and limits established herein shall not be interpreted as any representation or warranty that the insurance coverage and limits necessarily will be adequate to protect Contractor.
- 5.2.6 Coverage shall be written on an occurrence basis by companies authorized and admitted to do business in the State of Texas and rated A or better by A.M. Best Company or similar rating company or otherwise acceptable to Owner.

5.2.2.1 Insurance Coverage Required.

5.2.2.1.1 Workers' Compensation. Insurance with limits as required by the Texas Workers' Compensation Act, with the policy endorsed to provide a waiver of subrogation in favor of Owner, employer's liability insurance of not less than:

\$1,000,000 each accident;

\$1,000,000 disease each employee; and

\$1,000,000 disease policy limit.

5.2.2.1.2 Commercial General Liability Insurance. Including premises, operations, independent contractor's liability, products and completed operations and contractual liability, covering, but not limited to, the liability assumed under the indemnification provisions of this Contract, fully insuring Contractor's liability for bodily injury

(including death) and property damage with a minimum limit of:

\$1,000,000 per occurrence;

\$2,000,000 general aggregate;

\$5,000 Medical Expense each person;

\$1,000,000 Personal Injury and Advertising Liability;

\$2,000,000 products and completed operations aggregate;

\$50,000 Damage to Premises Rented to You; and

Coverage shall be on an “occurrence” basis.

The policy shall include coverage extended to apply to completed operations and explosion, collapse, and underground hazards. The policy shall include endorsement CG2503 Amendment of Aggregate Limits of Insurance (per Project) or its equivalent.

If the Work involves any activities within fifty (50) feet of any railroad, railroad protective insurance as may be required by the affected railroad, written for not less than the limits required by such railroad.

- 5.2.2.1.3 Asbestos Abatement Liability Insurance, including coverage for liability arising from the encapsulation, removal, handling, storage, transportation, and disposal of asbestos containing materials. *This requirement applies if the Work or the Project includes asbestos containing materials.

The combined single limit for bodily injury and property damage will be a minimum of \$1,000,000 per occurrence.

*Specific requirement for claims-made form: Required period of coverage will be determined by the following formula: continuous coverage for life of the Contract, plus one (1) year (to provide coverage for the warranty period), and an extended discovery period for a minimum of five (5) years which shall begin at the end of the warranty period.

Employer’s liability limits for asbestos abatement will be:

\$500,000 each accident;

\$500,000 disease each employee; and

\$500,000 disease policy limit.

If this Contract is for asbestos abatement only, the Special Form builder's risk or Special Form installation floater (e) is not required.

- 5.2.2.1.4 Comprehensive Automobile Liability Insurance, covering owned, hired, and non-owned vehicles, with a minimum combined single limit for bodily injury (including death) and property damage of \$1,000,000 per accident. No aggregate shall be permitted for this type of coverage.

Such insurance is to include coverage for loading and unloading hazards.

- 5.2.2.1.5 Special Form Builder's Risk Insurance, if applicable (or Special Form installation floater for instances in which the project involves solely the installation of material and/or equipment). Coverage shall be Special Form, including, but not limited to, fire, extended coverage, vandalism and malicious mischief, theft and, if applicable, flood, earth movement and named storm. Builder's risk and installation floater limits shall be equal to 100 percent of the Contract Sum plus, if any, existing property and Owner-furnished equipment specified by Owner. The policy shall be written jointly in the names of Owner and Contractor. Subcontractors shall be named as additional insureds. The policy shall have endorsements as follows:

5.2.2.1.5.1 This insurance shall be specific as to coverage and not contributing insurance with any permanent insurance maintained on the property.

5.2.2.1.5.2 This insurance shall not contain an occupancy clause suspending or reducing coverage should Owner partially occupy the Site and before the parties have determined Substantial Completion.

5.2.2.1.5.3 Loss, if any, shall be adjusted with and made payable to Owner as trustee for the insureds as their interests may appear. Owner shall be named as loss payee.

5.2.2.1.5.4 For renovation projects or projects that involve portions of Work contained within an existing structure, refer to Supplementary General and Special Conditions for possible additional builder's risk insurance requirements.

5.2.2.1.5.5 For Owner furnished equipment or materials that will be in care, custody or control of Contractor, Contractor will be responsible for damage and loss.

5.2.2.1.5.6 For those properties located within a Tier 1 or 2 windstorm area, named storm coverage must be provided with limits specified by Owner.

5.2.2.1.5.7 For those properties located in flood prone areas, flood insurance coverage must be provided with limits specified by Owner.

5.2.2.1.5.8 Builder's risk insurance policy shall remain in effect until Substantial Completion.

5.2.2.1.6 "Umbrella" Liability Insurance. Contractor shall obtain, pay for and maintain umbrella liability insurance during the Contract term, insuring Contractor for an amount of not less than amount specified in the Supplementary General Conditions or Special Conditions that provides coverage at least as broad as and applies in excess and follows form of the primary liability coverages required hereinabove. The policy shall provide "drop down" coverage where underlying primary insurance coverage limits are insufficient or exhausted.

5.2.3 Policies must include the following clauses, as applicable:

5.2.3.1 This insurance shall not be canceled, materially changed, or non-renewed except after thirty (30) days written notice has been given to Owner.

5.2.3.2 It is agreed that Contractor's insurance shall be deemed primary with respect to any insurance or self insurance carried by Owner for liability arising out of operations under the Contract with Owner.

5.2.3.3 Owner, its officials, directors, employees, representatives, and volunteers are added as additional insureds as respects operations and activities of, or on behalf of the named insured performed under Contract with Owner. The additional insured status must cover

completed operations as well. This is not applicable to workers' compensation policies.

- 5.2.3.4 A waiver of subrogation in favor of Owner shall be provided in all policies.

- 5.2.4 Without limiting any of the other obligations or liabilities of Contractor, Contractor shall require each Subcontractor performing work under the Contract, at Subcontractor's own expense, to maintain during the term of the Contract, the same stipulated minimum insurance including the required provisions and additional policy conditions as shown above. As an alternative, Contractor may include its Subcontractors as additional insureds on its own coverage as prescribed under these requirements. Contractor's certificate of insurance shall note in such event that Subcontractors are included as additional insureds and that Contractor agrees to provide workers' compensation for Subcontractors and their employees. Contractor shall obtain and monitor the certificates of insurance from each Subcontractor in order to assure compliance with the insurance requirements. Contractor must retain the certificates of insurance for the duration of the Contract plus five (5) years and shall have the responsibility of enforcing these insurance requirements among its Subcontractors. Owner shall be entitled, upon request and without expense, to receive copies of these certificates.

- 5.2.5 Workers' compensation insurance coverage must be provided for all workers at all tier levels and meet the statutory requirements of Tex. Lab. Code § 401.011(44) and specific to construction projects for public entities as required by Tex. Lab. Code § 406.096.

Article 6. Construction Documents, Coordination Documents, and Record Documents

6.1 Drawings and Specifications.

- 6.1.1 Copies Furnished. Contractor will be furnished, free of charge, the number of complete sets of the Drawings, Specifications, and Addenda as provided in the Supplementary General Conditions or Special Conditions. Additional complete sets of Drawings and Specifications, if requested, will be furnished at reproduction cost to the entity requesting such additional sets. Electronic copies of such documents will be provided to Contractor without charge. ***Unless otherwise called for in the Special Conditions, four (4) sets of drawings and specifications will be furnished to the Contractor free of charge upon justification of need.***
- 6.1.2 Ownership of Drawings and Specifications. All Drawings, Specifications and copies thereof furnished by A/E are to remain A/E's property ***unless the Owner and A/E agree otherwise.*** These documents are not to be used on any other project, and with the exception of the Contract record set and electronic versions needed for warranty operations, are to be returned to the A/E, upon request, following completion of the Work.
- 6.1.3 Interrelation of Documents. The Contract Documents as referenced in the Contract between Owner and Contractor are complimentary, and what is required by one shall be as binding as if required by all.
- 6.1.4 Resolution of Conflicts in Documents. Where conflicts may exist within the Contract Documents, the documents shall govern in the following order: (a) Change Orders, addenda, and written amendments to the Contract; (b) the Contract; (c) Drawings; (d) Specifications (but Specifications shall control over Drawings as to quality of materials and workmanship); and (e) other Contract Documents. Among categories of documents having the same order of precedence, the term or provision that includes the latest date shall control and more specific requirements shall govern over general requirements. Contractor shall notify A/E and ODR for resolution of the issue prior to executing the Work in question.
- 6.1.5 Contractor's Duty to Review Contract Documents. In order to facilitate its responsibilities for completion of the Work in accordance with and as reasonably inferable from the Contract Documents, prior to commencing the Work, Contractor shall examine and compare the Contract Documents, information furnished by Owner, relevant field measurements made by Contractor and any visible or reasonably anticipated conditions at the Site affecting the Work. This duty extends throughout the construction phase prior to commencing each particular work activity and/or system installation.

6.1.6 Discrepancies and Omissions in Drawings and Specifications.

- 6.1.6.1 Promptly report to ODR and to A/E the discovery of any apparent error, omission or inconsistency in the Contract Documents prior to execution of the Work. ***The Owner does not warrant or make any representations as to the accuracy or completeness of the information furnished to the Contractor by the Owner***
- 6.1.6.2 It is recognized that Contractor is not acting in the capacity of a licensed design professional, unless it is performing as a Design-Build firm.
- 6.1.6.3 It is further recognized that Contractor's examination of Contract Documents is to facilitate construction and does not create an affirmative responsibility to detect errors, omissions or inconsistencies or to ascertain compliance with applicable laws, building codes or regulations, unless it is performing as a Design-Build firm or a Construction Manager-at-Risk.
- 6.1.6.4 When performing as a Design-Build firm, Contractor has sole responsibility for discrepancies, errors, and omissions in the Drawings and Specifications.
- 6.1.6.5 When performing as a Construction Manager-at-Risk, Contractor has a shared responsibility with A/E for discovery and resolution of discrepancies, errors, and omissions in the Contract Documents. In such case, Contractor's responsibility pertains to review, coordination, and recommendation of resolution strategies within budget constraints.
- 6.1.6.6 Contractor has no liability for errors, omissions, or inconsistencies unless Contractor knowingly failed to report a recognized problem to Owner or the Work is executed under a Design-Build or Construction Manager-at-Risk Contract as outlined above. Should Contractor fail to perform the examination and reporting obligations of these provisions, Contractor is responsible for avoidable costs and direct and/or consequential damages.

6.2 Requirements for Record Documents. Contractor shall:

- 6.2.1 Maintain at the Site one copy of all Drawings, Specifications, addenda, approved submittals, Contract modifications, and all Project correspondence. Keep current and maintain Drawings and Specifications in good order with postings and markings to record actual conditions of Work and show and reference all changes made during construction. Provide Owner and A/E access to these documents.

- 6.2.2 Maintain the ~~Record Documents~~ **As-Builts** including Drawings, Specifications and other materials which reflect the actual field conditions and representations of the Work performed, whether it be directed by addendum, Change Order or otherwise. Make available all records prescribed herein for reference and examination by Owner and its representatives and agents.
- 6.2.3 Update the ~~Record Documents~~ **As-Builts** at least monthly prior to submission of periodic partial pay estimates. Failure to maintain current Record Documents constitutes cause for denial of a progress payment otherwise due.
- 6.2.4 Prior to requesting Substantial Completion inspection Contractor shall furnish a copy of its marked-up ~~Record Documents~~ **As-Builts** and a preliminary copy of each instructional manual, maintenance and operating manual, parts catalog, wiring diagrams, spare parts, specified written warranties and like publications, or parts for all installed equipment, systems, and like items and as described in the Contract Documents. (Unexecuted samples of the aforementioned documentation may be reviewed by ODR when the absence of substantial completion transactions preclude execution; however, Contractor remains obligated to provide fully executed copies of such materials prior to final payment.)
- 6.2.5 Once determined acceptable by ODR with input from A/E, provide one (1) reproducible copy and one (1) electronic media copy of all ~~Record Documents~~ **As-Built documents** unless otherwise required by the Supplementary General Conditions or Special Conditions.
- 6.2.6 Contractor shall be responsible for updating the ~~Record~~ **As-Built** Documents for all Contractor initiated documents and changes to the Contract Documents due to coordination and actual field conditions, including RFIs.
- 6.2.7 A/E shall be responsible for updating the ~~Record~~ **As-Built** Documents ~~for~~ **with** any addenda, Change Orders, A/E supplemental instructions and any other alterations to the Contract Documents generated by A/E or Owner. **A/E shall be responsible for compiling all As-Built documentation (as produced both by the Contractor and by the A/E) into the Record Documents.**

Article 7. Construction Safety

- 7.1 General. It is the duty and responsibility of Contractor and all of its Subcontractors to be familiar with, enforce and comply with all requirements of Public Law No. 91-596, 29 U.S.C. § 651 et. seq., the Occupational Safety and Health Act of 1970, (OSHA) and all amendments thereto. Contractor shall prepare a safety plan specific to the Project and submit it to ODR and A/E prior to commencing Work. In addition, Contractor and all of its Subcontractors shall comply with all applicable laws and regulations of any public body having jurisdiction for safety of persons or property to protect them from damage, injury or loss and erect and maintain all necessary safeguards for such safety and protection.
- 7.2 Notices. Contractor shall provide notices as follows:
- 7.2.1 Notify owners of adjacent property including those that own or operate utility services and/or underground facilities, and utility owners, when prosecution of the Work may affect them or their facilities, and cooperate with them in the protection, removal, relocation and replacement, and access to their facilities and/or utilities.
- 7.2.2 Coordinate the exchange of material safety data sheets (MSDSs) or other hazard communication information required to be made available to or exchanged between or among employers at the site in connection with laws and regulations. Maintain a complete file of MSDSs for all materials in use on site throughout the construction phase and make such file available to Owner and its agents as requested.
- 7.3 Emergencies. In any emergency affecting the safety of persons or property, Contractor shall act to minimize, mitigate, and prevent threatened damage, injury or loss.
- 7.3.1 Have authorized agents of Contractor respond immediately upon call at any time of day or night when circumstances warrant the presence of Contractor to protect the Work or adjacent property from damage or to take such action pertaining to the Work as may be necessary to provide for the safety of the public.
- 7.3.2 Give ODR and A/E prompt notice of all such events.
- 7.3.3 If Contractor believes that any changes in the Work or variations from Contract Documents have been caused by its emergency response, promptly notify Owner within seventy-two (72) hours of the emergency response event.
- 7.3.4 Should Contractor fail to respond, Owner is authorized to direct other forces to take action as necessary and Owner may deduct any cost of remedial action from funds otherwise due Contractor.

- 7.4 Injuries. In the event of an incident or accident involving outside medical care for an individual on or near the Work, Contractor shall notify ODR and other parties as may be directed promptly, but no later than twenty-four (24) hours after Contractor learns that an event required medical care.
- 7.4.1 Record the location of the event and the circumstances surrounding it, by using photography or other means, and gather witness statements and other documentation which describes the event.
- 7.4.2 Supply ODR and A/E with an incident report no later than thirty-six (36) hours after the occurrence of the event. In the event of a catastrophic incident (one (1) fatality or three (3) workers hospitalized), barricade and leave intact the scene of the incident until all investigations are complete. A full set of incident investigation documents, including facts, finding of cause, and remedial plans shall be provided within one (1) week after occurrence, unless otherwise directed by legal counsel. Contractor shall provide ODR with written notification within one week of such catastrophic event if legal counsel delays submission of full report.
- 7.5 Environmental Safety. Upon encountering any previously unknown potentially hazardous material, or other materials potentially contaminated by hazardous material, Contractor shall immediately stop work activities impacted by the discovery, secure the affected area, and notify ODR immediately.
- 7.5.1 Bind all Subcontractors to the same duty.
- 7.5.2 Upon receiving such notice, ODR will promptly engage qualified experts to make such investigations and conduct such tests as may be reasonably necessary to determine the existence or extent of any environmental hazard. Upon completion of this investigation, ODR will issue a written report to Contractor identifying the material(s) found and indicate any necessary steps to be taken to treat, handle, transport or dispose of the material.
- 7.5.3 Owner may hire third-party Contractors to perform any or all such steps.
- 7.5.4 Should compliance with ODR's instructions result in an increase in Contractor's cost of performance, or delay the Work, Owner will make an equitable adjustment to the Contract Sum and/or the time of completion, and modify the Contract in writing accordingly.
- 7.6 Trenching Plan. When the project requires excavation which either exceeds a depth of four (4) feet, or results in any worker's upper body being positioned below grade level, Contractor is required to submit a trenching plan to ODR prior to commencing trenching operations unless an engineered plan is part of the Contract Documents. The plan is required to be prepared and sealed by a professional engineer registered in the State of Texas, and hired or employed by Contractor or Subcontractor to perform the work. Said engineer cannot be anyone who is otherwise either directly or indirectly engaged on this project.

Article 8. Quality Control

- 8.1 Materials & Workmanship. Contractor shall execute Work in a good and workmanlike manner in accordance with the Contract Documents. Contractor shall develop and provide a quality control plan specific to this Project and acceptable to Owner. Where Contract Documents do not specify quality standards, complete and construct all Work in compliance with generally accepted construction industry standards. Unless otherwise specified, incorporate all new materials and equipment into the Work under the Contract.
- 8.2 Testing.
- 8.2.1 Owner is responsible for coordinating and paying for routine and special tests required to confirm compliance with quality and performance requirements, except as stated below or otherwise required by the Contract Documents. Contractor shall provide the following testing:
- 8.2.1.1 Any test of basic material or fabricated equipment included as part of a submittal for a required item in order to establish compliance with the Contract Documents.
- 8.2.1.2 Any test of basic material or fabricated equipment offered as a substitute for a specified item on which a test may be required in order to establish compliance with the Contract Documents.
- 8.2.1.3 Preliminary, start-up, pre-functional and operational testing of building equipment and systems as necessary to confirm operational compliance with requirements of the Contract Documents.
- 8.2.1.4 All subsequent tests on original or replaced materials conducted as a result of prior testing failure.
- 8.2.2 All testing shall be performed in accordance with standard test procedures by an accredited laboratory, or special consultant as appropriate, acceptable to Owner. Results of all tests shall be provided promptly to ODR, A/E, and Contractor.
- 8.2.3 Non-Compliance (Test Results). Should any of the tests indicate that a material and/or system does not comply with the Contract requirements, the burden of proof remains with Contractor, subject to:
- 8.2.3.1 Contractor selection and submission of the laboratory for Owner acceptance.
- 8.2.3.2 Acceptance by Owner of the quality and nature of tests.
- 8.2.3.3 All tests taken in the presence of A/E and/or ODR, or their representatives.

- 8.2.3.4 If tests confirm that the material/systems comply with Contract Documents, Owner will pay the cost of the test.
- 8.2.3.5 If tests reveal noncompliance, Contractor will pay those laboratory fees and costs of that particular test and all future tests, of that failing Work, necessary to eventually confirm compliance with Contract Documents.
- 8.2.3.6 Proof of noncompliance with the Contract Documents will make Contractor liable for any corrective action which ODR determines appropriate, including complete removal and replacement of non-compliant work or material.
- 8.2.4 Notice of Testing. Contractor shall give ODR and A/E timely notice of its readiness and the date arranged so ODR and A/E may observe such inspection, testing, or approval. **Contractor shall give Owner a minimum of five (5) working days advance notice prior to testing.**
- 8.2.5 Test Samples. Contractor is responsible for providing Samples of sufficient size for test purposes and for coordinating such tests with their Work Progress Schedule to avoid delay.
- 8.2.6 Covering Up Work. If Contractor covers up any Work without providing Owner an opportunity to inspect, Contractor shall, if requested by ODR, uncover and recover the work at Contractor's expense.

8.3 Submittals.

- 8.3.1 Contractor's Submittals. Contractor shall submit with reasonable promptness consistent with the Project schedule and in orderly sequence all Shop Drawings, Samples, or other information required by the Contract Documents, or subsequently required by Change Order. Prior to submitting, Contractor shall review each submittal for general compliance with Contract Documents and approve submittals for review by A/E and Owner by an approval stamp affixed to each copy. Submittal data presented without Contractor's stamp will be returned without review or comment, and any delay resulting from failure is Contractor's responsibility.
 - 8.3.1.1 Contractor shall within twenty-one (21) days of the effective date of the Notice To Proceed with construction, submit to ODR and A/E, a submittal schedule/register, organized by specification section, listing all items to be furnished for review and approval by A/E and Owner. The list shall include Shop Drawings, manufacturer's literature, certificates of compliance, materials Samples, materials colors, guarantees, and all other items identified throughout the Specifications.
 - 8.3.1.2 Contractor shall indicate the type of item, Contract requirements reference, and Contractor's scheduled dates for submitting the item along with the requested dates for approval answers from A/E and

Owner. The submittal register shall indicate the projected dates for procurement of all included items and shall be updated at least monthly with actual approval and procurement dates. Contractor's Submittal Register must be reasonable in terms of the review time for complex submittals. Contractor's submittal schedule must be consistent with the Work Progress Schedule and identify critical submittals. Show and allow a minimum of fifteen (15) calendar days duration after receipt by A/E and ODR for review and approval. If resubmittal required, allow a minimum of an additional fifteen (15) calendar days for review. Submit the updated Submittal Register with each request for progress payment. Owner may establish routine review procedures and schedules for submittals at the preconstruction conference and/or elsewhere in the Contract Documents. If Contractor fails to update and provide the Submittal Register as required, Owner may, after seven (7) days notice to Contractor withhold a reasonable sum of money that would otherwise be due Contractor.

8.3.1.3 Contractor shall coordinate the Submittal Register with the Work Progress Schedule. Do not schedule Work requiring a submittal to begin prior to scheduling review and approval of the related submittal. Revise and/or update both schedules monthly to ensure consistency and current project data. Provide to ODR the updated Submittal Register and schedule with each application for progress payment. Refer to requirements for the Work Progress Schedule for inclusion of procurement activities therein. Regardless, the Submittal Register shall identify dates submitted and returned and shall be used to confirm status and disposition of particular items submitted, including approval or other action taken and other information not conveniently tracked through the Work Progress Schedule.

8.3.1.4 By submitting Shop Drawings, Samples or other required information, Contractor represents that it has determined and verified all applicable field measurements, field construction criteria, materials, catalog numbers and similar data to the extent possible from existing conditions and design information provided by A/E prior to fabrication; and has checked and coordinated each Shop Drawing and Sample with the requirements of the Work and the Contract Documents.

8.3.2 Review of Submittals. A/E and ODR review is only for conformance with the design concept and the information provided in the Contract Documents. Responses to submittals will be in writing. The approval of a separate item does not indicate approval of an assembly in which the item functions. The approval of a submittal does not relieve Contractor of responsibility for any deviation from the requirements of the Contract unless Contractor informs A/E and ODR of such deviation in a clear, conspicuous, and written manner on the submittal transmittal and at the time of submission, and obtains Owner's

written specific approval of the particular deviation.

- 8.3.3 Correction and Resubmission. Contractor shall make any corrections required to a submittal and resubmit the required number of corrected copies promptly so as to avoid delay, until submittal approval. Direct attention in writing to A/E and ODR, when applicable, to any new revisions other than the corrections requested on previous submissions.
- 8.3.4 Limits on Shop Drawing Review. Contractor shall not commence any Work requiring a submittal until review of the submittal **is fully executed** under Subsection 8.3.2. Construct all such work in accordance with reviewed submittals. Comments incorporated as part of the review in Subsection 8.3.2 of Shop Drawings and Samples is not authorization to Contractor to perform extra work or changed work unless authorized through a Change Order. A/E's and ODR's review, if any, does not relieve Contractor from responsibility for defects in the Work resulting from errors or omissions of any kind on the submittal, regardless of any approval action. A/E or ODR shall not make formal changes to the Contract Documents via the submittal process. Changes to the Construction Documents shall be accomplished via Section 3.2.2 and Article 11 Changes.
- 8.3.5 No Substitutions Without Approval. ODR and A/E may receive and consider Contractor's request for substitution when Contractor agrees to reimburse Owner for review costs and satisfies the requirements of this section. If Contractor does not satisfy these conditions, ODR and A/E will return the request without action except to record noncompliance with these requirements. Owner will not consider the request if Contractor cannot provide the product or method because of failure to pursue the Work promptly or coordinate activities properly. Contractor's request for a substitution may be considered by ODR and A/E when:
- 8.3.5.1 The Contract Documents do not require extensive revisions; and
 - 8.3.5.2 Proposed changes are in keeping with the general intent of the Contract Documents and the design intent of A/E and do not result in an increase in cost to Owner; and
 - 8.3.5.3 The request is timely, fully documented, properly submitted and one or more of the following apply:
 - 8.3.5.3.1 Contractor cannot provide the specified product, assembly or method of construction within the Contract Time;
 - 8.3.5.3.2 The request directly relates to an "or-equal" clause or similar language in the Contract Documents;
 - 8.3.5.3.3 The request directly relates to a "product design standard" or "performance standard" clause in the Contract

Documents;

- 8.3.5.3.4 The requested substitution offers Owner a substantial advantage in cost, time, energy conservation or other considerations, after deducting additional responsibilities Owner must assume;
- 8.3.5.3.5 The specified product or method of construction cannot receive necessary approval by an authority having jurisdiction, and ODR can approve the requested substitution;
- 8.3.5.3.6 Contractor cannot provide the specified product, assembly or method of construction in a manner that is compatible with other materials and where Contractor certifies that the substitution will overcome the incompatibility;
- 8.3.5.3.7 Contractor cannot coordinate the specified product, assembly or method of construction with other materials and where Contractor certifies they can coordinate the proposed substitution; or
- 8.3.5.3.8 The specified product, assembly or method of construction cannot provide a warranty required by the Contract Documents and where Contractor certifies that the proposed substitution provides the required warranty.
- 8.3.5.3.9 The manufacturer of the specified product has been removed from production due to cancellation or obsolescence.

8.3.6 Unauthorized Substitutions at Contractor's Risk. Contractor is financially responsible for any additional costs or delays resulting from unauthorized substitution of materials, equipment or fixtures other than those specified. Contractor shall reimburse Owner for any increased design or contract administration costs resulting from such unauthorized substitutions.

8.4 Field Mock-up.

8.4.1 Mock-ups shall be constructed prior to commencement of a specified scope of work to confirm acceptable workmanship.

8.4.1.1 As a minimum, field mock-ups shall be constructed for roofing systems, exterior veneer / finish systems, glazing systems, and any other Work requiring a mock-up as identified throughout the Contract Documents. Mock-ups for systems not part of the Project scope shall not be required.

8.4.1.2 Mock-ups may be incorporated into the Work if allowed by the

Contract Documents and if acceptable to ODR. If mock-ups are freestanding, they shall remain in place until otherwise directed by Owner.

- 8.4.1.3 Contractor shall include field mock-ups in their Work Progress Schedule and shall notify ODR and A/E of readiness for review sufficiently in advance to coordinate review without delay.

8.5 Inspection During Construction.

8.5.1 Contractor shall provide sufficient, safe, and proper facilities, including equipment as necessary for safe access, at all reasonable times for observation and/or inspection of the Work by Owner and its agents. "Reasonable times" of inspection allow for sufficient monitoring of the quality of materials and installation without substantially impeding the progress of the Work.

8.5.2 Contractor shall not cover up any Work with finishing materials or other building components prior to providing Owner and its agents an opportunity to perform an inspection of the Work.

8.5.2.1 Should corrections of the Work be required for approval, Contractor shall not cover-up corrected Work until Owner indicates approval.

8.5.2.2 Contractor shall provide notification of at least five (5) working days or otherwise as mutually agreed, to ODR of the anticipated need for a cover-up inspection. Should ODR fail to make the necessary inspection within the agreed period, Contractor may proceed with cover-up Work **after making every reasonable effort to contact the ODR and after documenting the Work**, but is not relieved of responsibility for Work to comply with requirements of the Contract Documents.

Article 9. Construction Schedules

- 9.1 Contract Time. **TIME IS AN ESSENTIAL ELEMENT OF THE CONTRACT.** The Contract Time is the time between the dates indicated in the Notice to Proceed for commencement of the Work and for achieving Substantial Completion. The Contract Time can be modified only by Change Order. Failure to achieve Substantial Completion within the Contract Time as otherwise agreed to in writing will cause damage to Owner and may subject Contractor to liquidated damages as provided in the Contract Documents. If Contractor fails to achieve Final Completion within thirty (30) calendar days after Substantial Completion or a mutually agreed upon longer period of time between Contractor and Owner, Contractor shall be responsible for Owner's additional inspection, project management, and maintenance cost to the extent caused by Contractor's failure to achieve Final Completion.
- 9.2 Notice to Proceed. Owner will issue a Notice to Proceed which shall state the dates for beginning Work and for achieving Substantial Completion of the Work.
- 9.3 Work Progress Schedule. Refer to Supplementary General Conditions or Special Conditions for additional schedule requirements. Unless indicated otherwise in those documents, Contractor shall submit their initial Work Progress Schedule for the Work in relation to the entire Project not later than twenty-one (21) days after the effective date of the Notice to Proceed to ODR and A/E. Unless otherwise indicated in the Contract Documents, the Work Progress Schedule shall be computerized Critical Path Method (CPM) with fully editable logic. This initial schedule shall indicate the dates for starting and completing the various aspects required to complete the Work, including mobilization, procurement, installation, testing, inspection, delivery of Close-out Documents and acceptance of all the Work of the Contract. When acceptable to Owner, the initially accepted schedule shall be the Baseline Schedule for comparison to actual conditions throughout the Contract duration.
- 9.3.1 Schedule Requirements. Contractor shall submit electronic and paper copy of the initial Work Progress Schedule reflecting accurate and reliable representations of the planned progress of the Work, the Work to date if any, and of Contractor's actual plans for its completion. Contractor shall organize and provide adequate detail so the schedule is capable of measuring and forecasting the effect of delaying events on completed and uncompleted activities.
- 9.3.1.1 Contractor shall resubmit initial schedule as required to address review comments from A/E and ODR until such schedule is accepted as the Baseline Schedule.
- 9.3.1.2 Submittal of a schedule, schedule revision or schedule update constitutes Contractor's representation to Owner of the accurate depiction of all progress to date and that Contractor will follow the schedule as submitted in performing the Work.

- 9.3.2 Schedule Updates. Contractor shall update the Work Progress Schedule and the Submittal Register monthly, as a minimum, to reflect progress to date and current plans for completing the Work, while maintaining original schedule as Baseline Schedule and submit paper and electronic copies of the update to A/E and ODR as directed, but as a minimum with each request for payment. Owner has no duty to make progress payments unless accompanied by the updated Work Progress Schedule. Show the anticipated date of completion reflecting all extensions of time granted through Change Order as of the date of the update. Contractor may revise the Work Progress Schedule when in Contractor's judgment it becomes necessary for the management of the Work. Contractor shall identify all proposed changes to schedule logic to Owner and to A/E via an executive summary accompanying the updated schedule for review prior to final implementation of revisions into a revised Baseline Schedule. Schedule changes that materially impact Owner's operations shall be communicated promptly to ODR and shall not be incorporated into the revised Baseline Schedule without ODR's consent.
- 9.3.3 The Work Progress Schedule is for Contractor's use in managing the Work and submittal of the schedule, and successive updates or revisions, is for the information of Owner and to demonstrate that Contractor has complied with requirements for planning the Work. Owner's acceptance of a schedule, schedule update or revision constitutes Owner's agreement to coordinate its own activities with Contractor's activities as shown on the schedule.
- 9.3.3.1 Acceptance of the Work Progress Schedule, or update and/or revision thereto does not indicate any approval of Contractor's proposed sequences and duration.
- 9.3.3.2 Acceptance of a Work Progress Schedule update or revision indicating early or late completion does not constitute Owner's consent, alter the terms of the Contract, or waive either Contractor's responsibility for timely completion or Owner's right to damages for Contractor's failure to do so.
- 9.3.3.3 Contractor's scheduled dates for completion of any activity or the entire Work do not constitute a change in terms of the Contract. Change Orders are the only method of modifying the Substantial Completion Date(s) and Contract Time.
- 9.4 Ownership of Float. Unless indicated otherwise in the Contract Documents, Contractor shall develop its schedule, pricing, and execution plan to provide a minimum of ten (10) percent total float at acceptance of the Baseline Schedule. Float time contained in the Work Progress Schedule is not for the exclusive benefit of Contractor or Owner, but belongs to the Project and may be consumed by either party as needed on a first-used basis.
- 9.5 Completion of Work. Contractor is accountable for completing the Work within the Contract Time stated in the Contract, or as otherwise amended by Change Order.

- 9.5.1 If, in the judgment of Owner, the work is behind schedule and the rate of placement of work is inadequate to regain scheduled progress to insure timely completion of the entire work or a separable portion thereof, Contractor, when so informed by Owner, shall immediately take action to increase the rate of work placement by:
 - 9.5.1.1 An increase in working forces.
 - 9.5.1.2 An increase in equipment or tools.
 - 9.5.1.3 An increase in hours of work or number of shifts.
 - 9.5.1.4 Expedite delivery of materials.
 - 9.5.1.5 Other action proposed if acceptable to Owner.
- 9.5.2 Within ten (10) days after such notice from ODR, Contractor shall notify ODR in writing of the specific measures taken and/or planned to increase the rate of progress. Contractor shall include an estimate as to the date of scheduled progress recovery and an updated Work Progress Schedule illustrating Contractor's plan for achieving timely completion of the Project. Should ODR deem the plan of action inadequate, Contractor shall take additional steps or make adjustments as necessary to its plan of action until it meets with ODR's approval.
- 9.6 Modification of the Contract Time.
 - 9.6.1 Delays and extension of time as hereinafter described are valid only if executed in accordance with provisions set forth in Article 11.
 - 9.6.2 When a delay defined herein as excusable prevents Contractor from completing the Work within the Contract Time, Contractor is entitled to an extension of time. Owner will make an equitable adjustment and extend the number of days lost because of excusable delay or Weather Days, as measured by Contractor's progress schedule. All extensions of time will be granted in calendar days. In no event, however, will an extension of time be granted for delays that merely extend the duration of non-critical activities, or which only consume float without delaying the project Substantial Completion date(s).
 - 9.6.2.1 A "Weather Day" is a day on which Contractor's current schedule indicates Work is to be done, and on which inclement weather and/or related site conditions prevent Contractor from performing seven (7) continuous hours of Work on the critical path between the hours of 7:00 a.m. and 6:00 p.m. Weather days are excusable delays. When weather conditions at the site prevent work from proceeding, Contractor shall immediately notify ODR for confirmation of the conditions. At the end of each calendar month, submit to ODR and A/E a list of Weather Days occurring in that month along with documentation of the impact on critical activities. Based on

confirmation by ODR, any time extension granted will be issued by Change Order. If Contractor and Owner cannot agree on the time extension, Owner may issue a ULCO for fair and reasonable time extension.

9.6.2.2 Excusable Delay. Contractor is entitled to an equitable adjustment of the Contract Time, issued via change order, for delays caused by the following:

9.6.2.2.1 Errors, omissions and imperfections in design, which A/E corrects by means of changes in the Drawings and Specifications.

9.6.2.2.2 Unanticipated physical conditions at the Site, which A/E corrects by means of changes to the Drawings and Specifications or for which ODR directs changes in the Work identified in the Contract Documents.

9.6.2.2.3 Failure of Owner to have secured property, right-of-way or easements necessary for Work to begin or progress.

9.6.2.2.4 Changes in the Work that effect activities identified in Contractor's schedule as "critical" to completion of the entire Work, if such changes are ordered by ODR or recommended by A/E and ordered by ODR.

9.6.2.2.5 Suspension of Work for unexpected natural events, Force Majeure (sometimes called "acts of God"), civil unrest, strikes or other events which are not within the reasonable control of Contractor.

9.6.2.2.6 Suspension of Work for convenience of ODR, which prevents Contractor from completing the Work within the Contract Time.

9.6.2.2.7 Administrative delays caused by activities or approval requirements related to an Authority Having Jurisdiction.

9.6.3 Contractor's relief in the event of such delays is the time impact to the critical path as determined by analysis of Contractor's schedule. In the event that Contractor incurs additional direct costs because of the excusable delays other than described in Subparagraph 9.6.2.2.4 and within the reasonable control of Owner, the Contract price and Contract Time are to be equitably adjusted by Owner pursuant to the provisions of Article 11.

9.7 No Damages for Delay. Contractor has no claim for monetary damages for delay or hindrances to the work from any cause, including without limitation any act or omission of Owner.

- 9.8 Concurrent Delay. When the completion of the Work is simultaneously delayed by an excusable delay and a delay arising from a cause not designated as excusable, Contractor may not be entitled to a time extension for the period of concurrent delay.
- 9.9 Other Time Extension Requests. Time extensions requested in association with changes to the Work directed or requested by Owner shall be included with Contractor's proposed costs for such change. Time extensions requested for inclement weather are covered by Paragraph 9.6.2.1 above. If Contractor believes that the completion of the Work is delayed by a circumstance other than for changes directed to the Work or weather, they shall give ODR written notice, stating the nature of the delay and the activities potentially affected, within five (5) days after the onset of the event or circumstance giving rise to the excusable delay. Contractor shall provide sufficient written evidence to document the delay. In the case of a continuing cause of delay, only one claim is necessary. State claims for extensions of time in numbers of whole or half days.
- 9.9.1 Within ten (10) days after the cessation of the delay, Contractor shall formalize its request for extension of time in writing to include a full analysis of the schedule impact of the delay and substantiation of the excusable nature of the delay. All changes to the Contract Time or made as a result of such claims is by Change Order, as set forth in Article 11.
- 9.9.2 No extension of time releases Contractor or the Surety furnishing a performance or payment bond from any obligations under the Contract or such a bond. Those obligations remain in full force until the discharge of the Contract.
- 9.9.3 Contents of Time Extension Requests. Contractor shall provide with each Time Extension Request a quantitative demonstration of the impact of the delay on project completion time, based on the Work Progress Schedule. Contractor shall include with Time Extension Requests a reasonably detailed narrative setting forth:
- 9.9.3.1 The nature of the delay and its cause; the basis of Contractor's claim of entitlement to a time extension.
- 9.9.3.2 Documentation of the actual impacts of the claimed delay on the critical path indicated in Contractor's Work Progress Schedule, and any concurrent delays.
- 9.9.3.3 Description and documentation of steps taken by Contractor to mitigate the effect of the claimed delay, including, when appropriate, the modification of the Work Progress Schedule.
- 9.9.4 Owner's Response. Owner will respond to the Time Extension Request by providing to Contractor written notice of the number of days granted, if any, and giving its reason if this number differs from the number of days requested by Contractor.
- 9.9.4.1 Owner will not grant time extensions for delays that do not affect the

Contract Substantial Completion date.

9.9.4.2 Owner will respond to each properly submitted Time Extension Request within fifteen (15) days following receipt. If Owner cannot reasonably make a determination about Contractor's entitlement to a time extension within that time, Owner will notify Contractor in writing. Unless otherwise agreed by Contractor, Owner has no more than fifteen (15) additional days to prepare a final response. If Owner fails to respond within forty-five (45) days from the date the Time Extension Request is received, Contractor is entitled to a time extension in the amount requested.

9.10 Failure to Complete Work Within the Contract Time. **TIME IS AN ESSENTIAL ELEMENT OF THE CONTRACT.** Contractor's failure to substantially complete the Work within the Contract Time or to achieve Substantial Completion as required will cause damage to Owner. These damages shall be liquidated by agreement of Contractor and Owner, in the amount per day as set forth in the Contract Documents.

9.11 Liquidated Damages. Owner may collect liquidated damages due from Contractor directly or indirectly by reducing the Contract Sum in the amount of liquidated damages stated in the Supplementary General Conditions or Special Conditions.

Article 10. Payments

- 10.1 Schedule of Values. Contractor shall submit to ODR and A/E for acceptance a Schedule of Values accurately itemizing material and labor for the various classifications of the Work based on the organization of the specification sections and of sufficient detail acceptable to ODR. The accepted Schedule of Values will be the basis for the progress payments under the Contract.
- 10.1.1 No progress payments will be made prior to receipt and acceptance of the Schedule of Values, provided in such detail as required by ODR, and submitted not less than twenty-one (21) days prior to the first request for payment. The Schedule of Values shall follow the order of trade divisions of the Specifications and include itemized costs for general conditions, costs for preparing close out documents, *staff training, if required*, fees, contingencies, and Owner cash allowances, if applicable, so that the sum of the items will equal the Contract price. As appropriate, assign each item labor and/or material values, the subtotal thereof equaling the value of the work in place when complete.
- 10.1.1.1 Owner requires that the Work items be inclusive of the cost of the Work items only. Any contract markups for overhead and profit, general conditions, etc., shall be contained within separate line items for those specific purposes which shall be divided into at least two (2) lines, one (1) for labor and one (1) for materials.
- 10.1.2 Contractor shall retain a copy of all worksheets used in preparation of its bid or proposal, supported by a notarized statement that the worksheets are true and complete copies of the documents used to prepare the bid or proposal. Make the worksheets available to ODR at the time of Contract execution. Thereafter Contractor shall grant Owner during normal business hours access to said copy of worksheets at any time during the period commencing upon execution of the Contract and ending one year after final payment.
- 10.2. Progress Payments. Contractor will receive periodic progress payments for Work performed, materials in place, suitably stored on Site, or as otherwise agreed to by Owner and Contractor. Payment is not due until receipt by ODR or his designee of a correct and complete Pay Application in electronic and/or hard copy format as set forth in Supplementary General Conditions, Special Conditions, and certified by A/E. Progress payments are made provisionally and do not constitute acceptance of work not in accordance with the Contract Documents. Owner will not process progress payment applications for Change Order Work until all parties execute the Change Order.
- 10.2.1 Preliminary Pay Worksheet. Once each month that a progress payment is to be requested, the Contractor shall submit to A/E and ODR a complete, clean copy of a preliminary pay worksheet or preliminary pay application, to include the following:

- 10.2.1.1 Contractor's estimate of the amount of Work performed, labor furnished and materials incorporated into the Work, using the established Schedule of Values;
 - 10.2.1.2 An updated Work Progress Schedule including the executive summary and all required schedule reports;
 - 10.2.1.3 HUB subcontracting plan Progress Assessment Report as required in Paragraph 4.2.5.1;
 - 10.2.1.4 Such additional documentation as Owner may require as set forth in the Supplementary General Conditions or elsewhere in the Contract Documents; and
 - 10.2.1.5 Construction payment affidavit. ***The referenced affidavit is the Contractor's Progress Payment Affidavit***
- 10.2.2 Contractor's Application for Payment. As soon as practicable, but in no event later than seven (7) days after receipt of the preliminary pay worksheet, A/E and ODR will meet with Contractor to review the preliminary pay worksheet and to observe the condition of the Work. Based on this review, ODR and A/E may require modifications to the preliminary pay worksheet prior to the submittal of an Application for Payment, and will promptly notify Contractor of revisions necessary for approval. As soon as practicable, Contractor shall submit its Application for Payment on the appropriate and completed form, reflecting the required modifications to the Schedule of Values required by A/E and/or ODR. Attach all additional documentation required by ODR and/or A/E, as well as an affidavit affirming that all payrolls, bills for labor, materials, equipment, subcontracted work and other indebtedness connected with Contractor's Application for Payment are paid or will be paid within the time specified in Tex. Gov't Code, Ch. 2251. No Application for Payment is complete unless it fully reflects all required modifications, and attaches all required documentation including Contractor's affidavit.
- 10.2.3 Certification by Architect/Engineer. Within five (5) days or earlier following A/E's receipt of Contractor's formal Application for Payment, A/E will review the Application for Payment for completeness, and forward it to ODR. A/E will certify that the application is complete and payable, or that it is incomplete, stating in particular what is missing. If the Application for Payment is incomplete, Contractor shall make the required corrections and resubmit the Application for Payment for processing.
- 10.3 Owner's Duty to Pay. Owner has no duty to pay the Contractor except on receipt by ODR of: 1) a complete Application for Payment certified by A/E; 2) Contractor's updated Work Progress Schedule; and 3) confirmation that Contractor's record documentation at the Site is kept current.

- 10.3.1 Payment for stored materials and/or equipment confirmed by Owner and A/E to be on-site or otherwise properly stored is limited to eighty-five (85) percent of the invoice price or eighty-five (85) percent of the scheduled value for the materials or equipment, whichever is less.
- 10.3.2 Retainage. Owner will withhold from each progress payment, as retainage, five (5) percent of the total earned amount, the amount authorized by law, or as otherwise set forth in the Supplementary General Conditions or Special Conditions. Retainage is managed in conformance with Tex. Gov't Code, Ch. 2252, Subch. B. ***The Owner shall withhold as retainage ten percent (10%) of the amount of each progress payment on all contracts estimated at time of execution to cost less than \$400,000 and five percent (5%) of the amount of each progress payment on all contracts estimated at the time of execution to cost \$400,000 or more.***
- 10.3.2.1 Contractor shall provide written consent of its surety for any request for reduction or release of retainage.
- 10.3.2.2 At least sixty-five (65) percent of the Contract, or such other discrete Work phase as set forth in Subsection 12.1.6 or Work package delineated in the Contract Documents, must be completed before Owner can consider a retainage reduction or release.
- 10.3.2.3 Contractor shall not withhold retainage from their Subcontractors and suppliers in amounts that are any percentage greater than that withheld in its Contract with Owner under this subsection, unless otherwise acceptable to Owner.
- 10.3.3 Price Reduction to Cover Loss. Owner may reduce any Application for Payment, prior to payment to the extent necessary to protect Owner from loss on account of actions of Contractor including, but not limited to, the following:
- 10.3.3.1 Defective or incomplete Work not remedied;
- 10.3.3.2 Damage to Work of a separate Contractor;
- 10.3.3.3 Failure to maintain scheduled progress or reasonable evidence that the Work will not be completed within the Contract Time;
- 10.3.3.4 Persistent failure to carry out the Work in accordance with the Contract Documents;
- 10.3.3.5 Reasonable evidence that the Work cannot be completed for the unpaid portion of the Contract Sum;
- 10.3.3.6 Assessment of fines for violations of prevailing wage rate law; or
- 10.3.3.7 Failure to include the appropriate amount of retainage for that

periodic progress payment.

10.3.3.8 Failure to maintain or allow Owner's inspection of payroll records.

10.3.4 Title to all material and Work covered by progress payments transfers to Owner upon payment.

10.3.4.1 Transfer of title to Owner does not relieve Contractor and its Subcontractors of the sole responsibility for the care and protection of materials and Work upon which payments have been made until substantial completion, responsibility for the care and protection of materials and Work in areas where punch list items are completed until final completion or the restoration of any damaged Work, or waive the right of Owner to require the fulfillment of all the terms of the Contract.

10.4 Progress Payments. Progress payments to Contractor do not release Contractor or its surety from any obligations under the Contract.

10.4.1 Upon Owner's request, Contractor shall furnish manifest proof of the status of Subcontractor's accounts in a form acceptable to Owner.

10.4.2 Pay estimate certificates must be signed by a corporate officer or a representative duly authorized by Contractor.

10.4.3 Provide copies of bills of lading, invoices, delivery receipts or other evidence of the location and value of such materials in requesting payment for materials.

10.4.4 For purposes of Tex. Gov't Code § 2251.021(a)(2), the date the performance of service is complete is the date when ODR approves the Application for Payment.

10.5 Off-Site Storage. With prior approval by Owner and in the event Contractor elects to store materials at an off-site location, abide by the following conditions, unless otherwise agreed to in writing by Owner.

10.5.1 Store materials in a commercial warehouse meeting the criteria stated below.

10.5.2 Provide insurance coverage adequate not only to cover materials while in storage, but also in transit from the off-site storage areas to the Project Site. Copies of duly authenticated certificates of insurance, made out to insure the State agency which is signatory to the Contract, must be filed with Owner's representative.

10.5.3 Inspection by Owner's representative is allowed at any time. Owner's inspectors must be satisfied with the security, control, maintenance, and preservation measures.

- 10.5.4 Materials for this Project are physically separated and marked for the Project in a sectioned-off area. Only materials which have been approved through the submittal process are to be considered for payment.
 - 10.5.5 Owner reserves the right to reject materials at any time prior to final acceptance of the complete Contract if they do not meet Contract requirements regardless of any previous progress payment made.
 - 10.5.6 With each monthly payment estimate, submit a report to ODR and A/E listing the quantities of materials already paid for and still stored in the off-site location.
 - 10.5.7 Make warehouse records, receipts and invoices available to Owner's representatives, upon request, to verify the quantities and their disposition.
 - 10.5.8 In the event of Contract termination or default by Contractor, the items in storage off-site, upon which payment has been made, will be promptly turned over to Owner or Owner's agents at a location near the jobsite as directed by ODR. The full provisions of performance and payment bonds on this Project cover the materials off-site in every respect as though they were stored on the Project Site.
- 10.6 Time for Payment by Contractor Pursuant to Tex. Gov't Code § 2255.022.
- 10.6.1 Contractor who receives a payment from a governmental entity shall pay Subcontractor the appropriate share of the payment not later than the tenth (10th) day after the date Contractor receives the payment.
 - 10.6.2 The appropriate share is overdue on the eleventh (11th) day after the date Contractor receives the payment.

Article 11. Changes

- 11.1 Change Orders. A Change Order issued after execution of the Contract is a written order to Contractor, signed by ODR, Contractor, and A/E, authorizing a change in the Work or an adjustment in the Contract Sum or the Contract Time. The Contract Sum and the Contract Time can only be changed by Change Order. A Change Order signed by Contractor indicates his agreement therewith, including the adjustment in the Contract Sum and/or the Contract Time. ODR may issue a written authorization for Contractor to proceed with Work of a Change Order in advance of final execution by all parties in accordance with Section 11.9.
- 11.1.1 Owner, without invalidating the Contract, **and without approval of the Contractor's Surety**, may order changes in the Work within the general scope of the Contract consisting of additions, deletions or other revisions, and the Contract Sum and the Contract Time will be adjusted accordingly. All such changes in the Work shall be authorized by Change Order or ULCO, and shall be performed under the applicable conditions of the Contract Documents. If such changes cause an increase or decrease in Contractor's cost of, or time required for, performance of the Contract, an equitable adjustment shall be made and confirmed in writing in a Change Order or a ULCO.
- 11.1.2 It is recognized by the parties hereto and agreed by them that the Specifications and Drawings may not be complete or free from errors, omissions and imperfections or that they may require changes or additions in order for the Work to be completed to the satisfaction of Owner and that, accordingly, it is the express intention of the parties, notwithstanding any other provisions in this Contract, that any errors, omissions or imperfections in such Specifications and Drawings, or any changes in or additions to same or to the Work ordered by Owner and any resulting delays in the Work or increases in Contractor's costs and expenses arising out of such errors, shall not constitute or give rise to any claim, demand or cause of action of any nature whatsoever in favor of Contractor, whether for breach of Contract, or otherwise; provided, however, that Owner shall be liable to Contractor for the sum stated to be due Contractor in any Change Order approved and signed by both parties, it being agreed hereby that such sum, together with any extension of time contained in said Change Order, shall constitute full compensation to Contractor for all costs, expenses and damages to Contractor, as permitted under Tex. Gov't Code, Ch. 2260.
- 11.1.3 Procedures for administration of Change Orders shall be established by Owner and stated in Supplementary General Conditions, Special Conditions, or elsewhere in the Contract Documents. **Procedures for administration of Change Orders will be provided at the Pre-Construction Conference.**
- 11.1.4 No verbal order, verbal statement, or verbal direction of Owner or his duly appointed representative shall be treated as a change under this article or entitle Contractor to an adjustment.

- 11.1.5 Contractor agrees that Owner or any of its duly authorized representatives shall have access and the right to examine any directly pertinent books, documents, papers, and records of Contractor. Further, Contractor agrees to include in all its subcontracts a provision to the effect that Subcontractor agrees that Owner or any of its duly authorized representatives shall have access to and the right to examine any directly pertinent books, documents, papers and records of such Subcontractor relating to any claim arising from the Contract, whether or not the Subcontractor is a party to the claim. The period of access and examination described herein which relates to appeals under the Disputes article of the Contract, litigation, or the settlement of claims arising out of the performance of the Contract shall continue until final disposition of such claims, appeals or litigation.
- 11.2 Unit Prices. If unit prices are stated in the Contract Documents or subsequently agreed upon, and if the quantities originally contemplated are so changed in a Proposed Change Order that application of the agreed unit prices to the quantities of work proposed will cause substantial inequity to Owner or Contractor, the applicable unit prices shall be equitably adjusted as provided in the Supplementary General Conditions or Special Conditions or as agreed to by the parties and incorporated into a Change Order.
- 11.3 Claims for Additional Costs.
- 11.3.1 If Contractor wishes to make a claim for an increase in the Contract Sum not related to a requested change, they shall give Owner and A/E written notice thereof within twenty-one (21) days after the occurrence of the event giving rise to such claim, but, in any case before proceeding to execute the Work considered to be additional cost or time, except in an emergency endangering life or property in which case Contractor shall act in accordance with Subsection 7.2.1. No such claim shall be valid unless so made. If Owner and Contractor cannot agree on the amount of the adjustment in the Contract Sum, it shall be determined as set forth under Article 15. Any change in the Contract Sum resulting from such claim shall be authorized by a Change Order or a ULCO.
- 11.3.2 If Contractor claims that additional cost is involved because of, but not limited to, 1) any written interpretation of the Contract Documents, 2) any order by Owner to stop the Work pursuant to Article 14 where Contractor was not at fault, or 3) any written order for a minor change in the Work issued pursuant to Section 11.4, Contractor shall make such claim as provided in Subsection 11.3.1.
- 11.3.3 Should Contractor or his Subcontractors fail to call attention of A/E to discrepancies or omissions in the Contract Documents, but claim additional costs for corrective Work after Contract award, Owner may assume intent to circumvent competitive bidding for necessary corrective Work. In such case, Owner may choose to let a separate Contract for the corrective Work, or issue a ULCO to require performance by Contractor. Claims for time extensions or

for extra cost resulting from delayed notice of patent Contract Document discrepancies or omissions will not be considered by Owner.

- 11.4 Minor Changes. A/E, with concurrence of ODR, will have authority to order minor changes in the Work not involving an adjustment in the Contract Sum or an extension of the Contract Time. Such changes shall be effected by written order which Contractor shall carry out promptly and record on As-Built ~~record~~ documents.
- 11.5 Concealed Site Conditions. Contractor is responsible for visiting the Site and being familiar with local conditions such as the location, accessibility, and general character of the Site and/or building. If, in the performance of the Contract, subsurface, latent, or concealed conditions at the Site are found to be materially different from the information included in the Contract Documents, or if unknown conditions of an unusual nature are disclosed differing materially from the conditions usually inherent in Work of the character shown and specified, ODR and A/E shall be notified in writing of such conditions before they are further disturbed or subsequent related work proceeds. Upon such notice, or upon its own observation of such conditions, A/E, with the approval of ODR, will promptly make such changes in the Drawings and Specifications as they deem necessary to conform to the different conditions, and any increase or decrease in the cost of the Work, or in the time within which the Work is to be completed, resulting from such changes will be adjusted by Change Order, subject to the prior approval of ODR.
- 11.6 Extension of Time. All changes to the Contract Time shall be made as a consequence of requests as required under Section 9.6, and as documented by Change Order as provided under Section 11.1.
- 11.7 Administration of Change Order Requests. All changes in the Contract shall be administered in accordance with procedures approved by Owner, and when required, make use of such electronic information management system(s) as Owner may employ.
- 11.7.1 Routine changes in the construction Contract shall be formally initiated by A/E by means of a PCO form detailing requirements of the proposed change for pricing by Contractor. This action may be preceded by communications between Contractor, A/E and ODR concerning the need and nature of the change, but such communications shall not constitute a basis for beginning the proposed Work by Contractor. Except for emergency conditions described below, approval of Contractor's cost proposal by A/E and ODR will be required for authorization to proceed with the Work being changed. Owner will not be responsible for the cost of Work changed without prior approval and Contractor may be required to remove Work so installed.
- 11.7.2 All proposed costs for change order Work must be supported by itemized accounting of material, equipment and associated itemized installation costs in sufficient detail, following the outline and organization of the established Schedule of Values, to permit analysis by A/E and ODR using current estimating guides and/or practices. Photocopies of Subcontractor and vendor proposals shall be furnished unless specifically waived by ODR. Contractor

shall provide written response to a change request within twenty-one (21) days of receipt.

- 11.7.3 Any unexpected circumstance which necessitates an immediate change in order to avoid a delay in progress of the Work may be expedited by verbal communication and authorization between Contractor and Owner, with written confirmation following within twenty-four (24) hours. A limited scope not-to-exceed estimate of cost and time will be requested prior to authorizing Work to proceed. Should the estimate be impractical for any reason, ODR may authorize the use of detailed cost records of such work to establish and confirm the actual costs and time for documentation in a formal Change Order.
- 11.7.4 Emergency changes to save life or property may be initiated by Contractor alone (see Section 7.3) with the claimed cost and/or time of such work to be fully documented as to necessity and detail of the reported costs and/or time.
- 11.7.5 The method of incorporating approved Change Orders into the parameters of the accepted Schedule of Values must be coordinated and administered in a manner acceptable to ODR.
- 11.8 Pricing Change Order Work. The amounts that Contractor and/or its Subcontractor adds to a Change Order for profit and overhead will also be considered by Owner before approval is given. The amounts established hereinafter are the maximums that are acceptable to Owner.
- 11.8.1 For Work performed by its forces, Contractor will be allowed their actual costs for materials, the total amount of wages (including benefits) paid for labor, plus the total cost of State and Federal payroll taxes and of worker's compensation and comprehensive general liability insurance, plus additional bond and builders risk insurance cost if the change results in an increase in the premium paid by Contractor. To the total of the above costs, Contractor will be allowed to add a percentage as noted below to cover overhead and profit combined. Allowable percentages for overhead and profit on any specific change shall not exceed fifteen (15) percent for the first \$10,000 of value for self-performed work or portion thereof, ten (10) percent for the second \$10,000 of value for self-performed work or portion thereof and seven and a half (7.5) percent for any value of the self-performed work that exceeds \$20,000.
- 11.8.2 For subcontracted Work each affected Subcontractor shall figure its costs, overhead and profit as described above for Contractor's Work, all Subcontractor costs shall be combined, and to that total Subcontractor cost Contractor will be allowed to add a maximum mark-up of ten (10) percent for the first \$10,000 of subcontracted Work value or portion thereof, seven and half (7.5) percent for the second \$10,000 of subcontracted Work value or portion thereof, and five (5) percent for any value of the subcontracted Work exceeding \$20,000.
- 11.8.3 On changes involving both additions and deletions, percentages for overhead and profit will be allowed only on the net addition. Owner does

not accept and will not pay for additional Contract cost identified as indirect or consequential damages.

- 11.8.4 For Contracts based on a Guaranteed Maximum Price (GMP), the Construction Manager-at-Risk or Design Builder shall NOT be entitled to a percentage mark-up on any Change Order Work unless the Change Order increases the Guaranteed Maximum Price.
- 11.8.5 ***If the parties cannot agree on an equitable adjustment for labor hours attributable to a change, they shall use the Means Facility Cost Data as a guide for labor hours as a basis of negotiation.***
- 11.9 Unilateral Change Order (ULCO). Owner may issue a written ULCO directing a change in the Work prior to reaching agreement with Contractor on the adjustment, if any, in the Contract price and/or the Contract Time.
- 11.9.1 Owner and Contractor shall negotiate for appropriate adjustments, as applicable, to the Contract Sum or the Contract Time arising out of a ULCO. As the changed Work is performed, Contractor shall submit its costs for such Work with its Application for Payment beginning with the next Application for Payment within thirty (30) days of the issuance of the ULCO. The Parties reserve their rights as to the disputed amount, subject to Article 15.
- 11.10 Final Resolution of Changes. Upon execution of a Change Order and /or a ULCO by Owner, Contractor and A/E, all costs and time issues regarding that change are final and not subject to additive adjustments.

Article 12. Project Completion and Acceptance

12.1 Closing Inspections.

12.1.1 Substantial Completion Inspection. When Contractor considers the entire Work or part thereof Substantially Complete, it shall notify ODR in writing **fifteen (15) working days prior to the Substantial Completion inspection** that the Work will be ready for Substantial Completion inspection on a specific date. Contractor shall include with this notice Contractor's Punchlist to indicate that it has previously inspected all the Work associated with the request for inspection, noting items it has corrected and included all remaining work items with date scheduled for completion or correction prior to final inspection. The failure to include any items on this list does not alter the responsibility of Contractor to complete all Work in accordance with the Contract Documents. If any of the items on this list prevents the Project from being used as intended, Contractor shall not request a Substantial Completion Inspection. Owner and its representatives will review the list of items and schedule the requested inspection, or inform Contractor in writing that such an inspection is premature because the Work is not sufficiently advanced or conditions are not as represented on Contractor's list.

12.1.1.1 Prior to the Substantial Completion inspection and as specified in the Special Conditions, Contractor shall furnish a copy of its marked-up ~~Record~~ **As-Built** Documents and a preliminary copy of each instructional manual, maintenance and operating manual, parts catalog, wiring diagrams, spare parts, specified written warranties, and like publications or parts for all installed equipment, systems, and like items as described in the Contract Documents. Delivery of these items is a prerequisite for requesting the Substantial Completion inspection.

12.1.1.2 On the date requested by Contractor, or as mutually agreed upon pending the status of the Open Items List, A/E, ODR, Contractor, and other Owner representatives as determined by Owner will jointly attend the Substantial Completion inspection, which shall be conducted by ODR or their delegate. If ODR determines that the Work is Substantially Complete, ODR will issue a Certificate of Substantial Completion to be signed by A/E, Owner, and Contractor establishing the date of Substantial Completion and identifying responsibilities for security, maintenance, insurance and utilities. A/E will provide with this certificate a consolidated list of Punchlist items (the pre-final Punchlist including all items noted by the various inspecting parties) for completion prior to final inspection. This list may include items in addition to those on Contractor's Punchlist, which the inspection team deems necessary to correct or complete prior to final inspection. The failure to include any items on this list does not alter the responsibility of Contractor to complete all Work in accordance with the Contract Documents. If Owner

occupies the Project upon determination of Substantial Completion, Contractor shall complete all corrective Work at the convenience of Owner, without disruption to Owner's use of the Project for its intended purposes.

12.1.2 Final Inspection. Contractor shall complete the list of items identified on the pre-final Punchlist prior to requesting a final inspection. Unless otherwise specified, or otherwise agreed in writing by the parties as documented on the Certificate of Substantial Completion, Contractor shall complete and/or correct all Work within thirty (30) days of the Substantial Completion date. Upon completion of the pre-final Punchlist work, Contractor shall give written notice to ODR and A/E that the Work will be ready for final inspection on a specific date. Contractor shall accompany this notice with a copy of the updated pre-final Punchlist indicating resolution of all items. On the date specified or as soon thereafter as is practicable, ODR, A/E and Contractor will inspect the Work. A/E will submit to Contractor a final Punchlist of open items that the inspection team requires corrected or completed before final acceptance of the Work.

12.1.2.1 Correct or complete all items on the final Punchlist before requesting Final Payment. Unless otherwise agreed to in writing by the parties, complete this work within seven (7) days of receiving the final Punchlist. Upon completion of the final Punchlist, notify A/E and ODR in writing stating the disposition of each final Punchlist item. A/E, Owner, and Contractor shall promptly inspect the completed items. When the final Punchlist is complete, and the Contract is fully satisfied according to the Contract Documents ODR will issue a certificate establishing the date of Final Completion. Completion of all Work is a condition precedent to Contractor's right to receive Final Payment.

12.1.3 Annotation. Any Certificate issued under this Article may be annotated to indicate that it is not applicable to specified portions of the Work, or that it is subject to any limitation as determined by Owner.

12.1.4 Purpose of Inspection. Inspection is for determining the completion of the Work, and does not relieve Contractor of its overall responsibility for completing the Work in a good and competent fashion, in compliance with the Contract. Work accepted with incomplete Punchlist items or failure of Owner or other parties to identify Work that does not comply with the Contract Documents or is defective in operation or workmanship does not constitute a waiver of Owner's rights under the Contract or relieve Contractor of its responsibility for performance or warranties.

12.1.5 Additional Inspections.

12.1.5.1 If Owner's inspection team determines that the Work is not substantially complete at the Substantial Completion inspection, ODR or A/E will give Contractor written notice listing cause(s) of

the rejection. Contractor will set a time for completion of incomplete or defective work acceptable to ODR. Contractor shall complete or correct all work so designated prior to requesting a second Substantial Completion inspection.

12.1.5.2 If Owner's inspection team determines that the Work is not complete at the final inspection, ODR or A/E will give Contractor written notice listing the cause(s) of the rejection. Contractor will set a time for completion of incomplete or defective work acceptable to ODR. Contractor shall complete or correct all Work so designated prior to again requesting a final inspection.

12.1.5.3 The Contract contemplates three (3) comprehensive inspections: the Substantial Completion inspection, the Final Completion inspection, and the inspection of completed final Punchlist items. The cost to Owner of additional inspections resulting from the Work not being ready for one or more of these inspections is the responsibility of Contractor. Owner may issue a ULCO deducting these costs from Final Payment. Upon Contractor's written request, Owner will furnish documentation of any costs so deducted. Work added to the Contract by Change Order after Substantial Completion inspection is not corrective Work for purposes of determining timely completion, or assessing the cost of additional inspections.

12.1.6 Phased Completion. The Contract may provide, or Project conditions may warrant, as determined by ODR, that designated elements or parts of the Work be completed in phases. Where phased completion is required or specifically agreed to by the parties, the provisions of the Contract related to closing inspections, occupancy, and acceptance apply independently to each designated element or part of the Work. For all other purposes, unless otherwise agreed by the parties in writing, Substantial Completion of the Work as a whole is the date on which the last element or part of the Work completed receives a Substantial Completion certificate.

Final Completion of the Work as a whole is the date on which the last element or part of the Work completed receives a Final Completion certificate.

12.2 Owner's Right of Occupancy. Owner may occupy or use all or any portion of the Work following Substantial Completion, or at any earlier stage of completion. Should Owner wish to use or occupy the Work, or part thereof, prior to Substantial Completion, ODR will notify Contractor in writing and identify responsibilities for security, maintenance, insurance and utilities. Work performed on the premises by third parties on Owner's behalf does not constitute occupation or use of the Work by Owner for purposes of this Article. All Work performed by Contractor after occupancy, whether in part or in whole, shall be at the convenience of Owner so as to not disrupt Owner's use of, or access to occupied areas of the Project.

12.3 Acceptance and Payment

- 12.3.1 Request for Final Payment. Following the certified completion of all work, including all final Punchlist items, cleanup, and the delivery of ~~record~~ **As-Built** documents, Contractor shall submit a certified Application for Final Payment and include all sums held as retainage and forward to A/E and ODR for review and approval.
- 12.3.2 Final Payment Documentation. Contractor shall submit, prior to or with the Application for Final Payment, final copies of all close out documents, maintenance and operating instructions, guarantees and warranties, certificates, ~~Record~~ **As-Built** Documents and all other items required by the Contract. Contractor shall submit evidence of return of access keys and cards, evidence of delivery to Owner of attic stock, spare parts, and other specified materials. Contractor shall submit consent of surety to Final Payment form and an affidavit that all payrolls, bills for materials and equipment, subcontracted work and other indebtedness connected with the Work, except as specifically noted, are paid, will be paid, after payment from Owner or otherwise satisfied within the period of time required by Tex. Gov't Code, Ch. 2251. Contractor shall furnish documentation establishing payment or satisfaction of all such obligations, such as receipts, releases and waivers of claims and liens arising out of the Contract. Contractor may not subsequently submit a claim on behalf of Subcontractor or vendor unless Contractor's affidavit notes that claim as an exception. ***The Affidavit referred to above is the Contractor's Final Payment Affidavit.***
- 12.3.3 Architect/Engineer Approval. A/E will review a submitted Application for Final Payment promptly but in no event later than ten (10) days after its receipt. Prior to the expiration of this deadline, A/E will either: 1) return the Application for Final Payment to Contractor with corrections for action and resubmission; or 2) accept it, note their approval, and send to Owner.
- 12.3.4 Offsets and Deductions. Owner may deduct from the Final Payment all sums due from Contractor. If the Certificate of Final Completion notes any Work remaining, incomplete, or defects not remedied, Owner may deduct the cost of remedying such deficiencies from the Final Payment. On such deductions, Owner will identify each deduction, the amount, and the explanation of the deduction on or by the twenty-first (21st) day after Owner's receipt of an approved Application for Final Payment. Such offsets and deductions shall be incorporated via a final Change Order, including a ULCO as may be applicable.
- 12.3.5 Final Payment Due. Final Payment is due and payable by Owner, subject to all allowable offsets and deductions, on the thirtieth (30th) day following Owner's approval of the Application for Payment. If Contractor disputes any amount deducted by Owner, Contractor shall give notice of the dispute on or before the thirtieth (30th) day following receipt of Final Payment. Failure to do so will bar any subsequent claim for payment of amounts deducted.
- 12.3.6 Effect of Final Payment. Final Payment constitutes a waiver of all claims by Owner, relating to the condition of the Work except those arising from:
- 12.3.6.1 Faulty or defective Work appearing after Substantial Completion

(latent defects);

- 12.3.6.2 Failure of the Work to comply with the requirements of the Contract Documents;
 - 12.3.6.3 Terms of any warranties required by the Contract, or implied by law; or
 - 12.3.6.4 Claims arising from personal injury or property damage to third parties.
- 12.3.7 Waiver of Claims. Final payment constitutes a waiver of all claims and liens by Contractor except those specifically identified in writing and submitted to ODR prior to the application for Final Payment.
- 12.3.8 Effect on Warranty. Regardless of approval and issuance of Final Payment, the Contract is not deemed fully performed by Contractor and closed until the expiration of all warranty periods. Issuance of Final Payment does not alter Contractor's contractual obligations during the warranty period.

Article 13. Warranty and Guarantee

- 13.1 Contractor's General Warranty and Guarantee. Contractor warrants to Owner that all Work is executed in accordance with the Contract, complete in all parts and in accordance with approved practices and customs, and of the required finish and workmanship. Contractor further warrants that unless otherwise specified, all materials and equipment incorporated in the Work under the Contract are new. Owner may, at its option, agree in writing to waive any failure of the Work to conform to the Contract, and to accept a reduction in the Contract price for the cost of repair or diminution in value of the Work by reason of such defect. Absent such a written agreement, Contractor's obligation to perform and complete the Work in accordance with the Contract Documents is absolute and is not waived by any inspection or observation by Owner, A/E or others, by making any progress payment or final payment, by the use or occupancy of the Work or any portion thereof by Owner, at any time, or by any repair or correction of such defect made by Owner.
- 13.2 Warranty Period. Except as may be otherwise specified or agreed, Contractor shall repair all defects in materials, equipment, or workmanship appearing within one year from the date of Substantial Completion of the Work **or at Final Completion if no Substantial Completion inspection is held.** If Substantial Completion occurs by phase, then the warranty period for that particular Work begins on the date of such occurrence, or as otherwise stipulated on the Certificate of Substantial Completion for the particular Work.
- 13.3 Limits on Warranty. Contractor's warranty and guarantee hereunder excludes defects or damage caused by:
- 13.3.1 Modification or improper maintenance or operation by persons other than Contractor, Subcontractors, or any other individual or entity for whom Contractor is not responsible, unless Owner is compelled to undertake maintenance or operation due to the neglect of Contractor.
 - 13.3.2 Normal wear and tear under normal usage after acceptance of the Work by Owner.
- 13.4 Events Not Affecting Warranty. Contractor's obligation to perform and complete the Work in a good and workmanlike manner in accordance with the Contract Documents is absolute. None of the following will constitute an acceptance of defective Work that is not in accordance with the Contract Documents or a release of Contractor's obligation to perform the Work in accordance with the Contract Documents:
- 13.4.1 Observations by Owner and/or A/E;
 - 13.4.2 Recommendation to pay any progress or final payment by A/E;
 - 13.4.3 The issuance of a certificate of Substantial Completion or any payment by Owner to Contractor under the Contract Documents;

- 13.4.4 Use or occupancy of the Work or any part thereof by Owner;
 - 13.4.5 Any acceptance by Owner or any failure to do so;
 - 13.4.6 Any review of a Shop Drawing or sample submittal; or
 - 13.4.7 Any inspection, test or approval by others.
- 13.5 Separate Warranties. If a particular piece of equipment or component of the Work for which the Contract requires a separate warranty is placed in continuous service before Substantial Completion, the warranty period for that equipment or component will not begin until Substantial Completion, regardless of any warranty agreements in place between suppliers and/or Subcontractors and Contractor. ODR will certify the date of service commencement in the Substantial Completion certificate.
- 13.5.1 In addition to Contractor's warranty and duty to repair, Contractor expressly assumes all warranty obligations required under the Contract for specific building components, systems and equipment.
 - 13.5.2 Contractor may satisfy any such obligation by obtaining and assigning to Owner a complying warranty from a manufacturer, supplier, or Subcontractor. Where an assigned warranty is tendered and accepted by Owner which does not fully comply with the requirements of the Contract, Contractor remains liable to Owner on all elements of the required warranty not provided by the assigned warranty.
- 13.6 Correction of Defects. Upon receipt of written notice from Owner, or any agent of Owner designated as responsible for management of the warranty period, of the discovery of a defect, Contractor shall promptly remedy the defect(s), and provide written notice to Owner and designated agent indicating action taken. In case of emergency where delay would cause serious risk of loss or damage to Owner, or if Contractor fails to remedy within thirty (30) days, or within another period agreed to in writing, Owner may correct the defect and be reimbursed the cost of remedying the defect from Contractor or its surety.
- 13.7 Certification of No Asbestos Containing Materials or Work. Contractor shall ensure compliance with the Asbestos Hazard Emergency Response Act (AHERA– 40 C.F.R. § 763-99(7)) from all Subcontractors and materials suppliers, and shall provide a notarized certification to Owner that all equipment and materials used in fulfillment of their Contract responsibilities are non-Asbestos Containing Building Materials (ACBM). This certification must be provided no later than Contractor's application for Final Payment.

Article 14. Suspension and Termination

14.1 Suspension of Work for Cause. Owner may, at any time without prior notice, suspend all or any part of the Work, if after reasonable observation and/or investigation, Owner determines it is necessary to do so to prevent or correct any condition of the Work, which constitutes an immediate safety hazard, or which may reasonably be expected to impair the integrity, usefulness or longevity of the Work when completed.

14.1.1 Owner will give Contractor a written notice of suspension for cause, setting forth the reason for the suspension and identifying the Work suspended. Upon receipt of such notice, Contractor shall immediately stop the Work so identified. As soon as practicable following the issuance of such a notice, Owner will initiate and complete a further investigation of the circumstances giving rise to the suspension, and issue a written determination of the findings.

14.1.2 If it is confirmed that the cause was within the control of Contractor, Contractor will not be entitled to an extension of time or any compensation for delay resulting from the suspension. If the cause is determined not to have been within the control of Contractor, and the suspension has prevented Contractor from completing the Work within the Contract Time, the suspension is an excusable delay and a time extension will be granted through a Change Order.

14.1.3 Suspension of Work under this provision will be no longer than is reasonably necessary to remedy the conditions giving rise to the suspension.

14.2 Suspension of Work for Owner's Convenience. Upon seven (7) days written notice to Contractor, Owner may at any time without breach of the Contract suspend all or any portion of the Work for a period of up to thirty (30) days for its own convenience. Owner will give Contractor a written notice of suspension for convenience, which sets forth the number of suspension days for which the Work, or any portion of it, and the date on which the suspension of Work will cease. When such a suspension prevents Contractor from completing the Work within the Contract Time, it is an excusable delay. A notice of suspension for convenience may be modified by Owner at any time on seven (7) days written notice to Contractor. If Owner suspends the Work for its convenience for more than sixty (60) consecutive days, Contractor may elect to terminate the Contract pursuant to the provisions of the Contract.

14.3 Termination by Owner for Cause.

14.3.1 Upon written notice to Contractor and its surety, Owner may, without prejudice to any right or remedy, terminate the Contract and take possession of the Site and of all materials, equipment, tools, construction equipment, and machinery thereon owned by Contractor under any of the following circumstances:

- 14.3.1.1 Persistent or repeated failure or refusal, except during complete or partial suspensions of work authorized under the Contract, to supply enough properly skilled workmen or proper materials;
 - 14.3.1.2 Persistent disregard of laws, ordinances, rules, regulations or orders of any public authority having jurisdiction, including ODR;
 - 14.3.1.3 Persistent failure to prosecute the Work in accordance with the Contract, and to ensure its completion within the time, or any approved extension thereof, specified in the Contract;
 - 14.3.1.4 Failure to remedy defective work condemned by ODR;
 - 14.3.1.5 Failure to pay Subcontractors, laborers, and material suppliers pursuant to Tex. Gov't Code, Ch. 2251;
 - 14.3.1.6 Persistent endangerment to the safety of labor or of the Work;
 - 14.3.1.7 Failure to supply or maintain statutory bonds or to maintain required insurance, pursuant to the Contract;
 - 14.3.1.8 Any material breach of the Contract; or
 - 14.3.1.9 Contractor's insolvency, bankruptcy, or demonstrated financial inability to perform the Work.
- 14.3.2 Failure by Owner to exercise the right to terminate in any instance is not a waiver of the right to do so in any other instance.
- 14.3.3 Should Owner decide to terminate the Contract under the provisions of Section 14.3, it will provide to Contractor and its surety thirty (30) days prior written notice.
- 14.3.4 Should Contractor or its surety, after having received notice of termination, demonstrate to the satisfaction of Owner that Contractor or its surety are proceeding to correct such default with diligence and promptness, upon which the notice of termination was based, the notice of termination may be rescinded in writing by Owner. If so rescinded, the Work may continue without an extension of time.
- 14.3.5 If Contractor or its surety fails, after written notice from Owner to commence and continue correction of such default with diligence and promptness to the satisfaction of Owner within thirty (30) days following receipt of notice, Owner may arrange for completion of the Work and deduct the cost of completion from the unpaid Contract Sum.
- 14.3.5.1 This amount includes the cost of additional Owner costs such as A/E services, other consultants, and contract administration.

14.3.5.2 Owner will make no further payment to Contractor or its surety unless the costs to complete the Work are less than the Contract balance, then the difference shall be paid to Contractor or its surety. If such costs exceed the unpaid balance, Contractor or its surety will pay the difference to Owner.

14.3.5.3 This obligation for payment survives the termination of the Contract.

14.3.5.4 Owner reserves the right in termination for cause to take assignment of all the Contracts between Contractor and its Subcontractors, vendors, and suppliers. ODR will promptly notify Contractor of the contracts Owner elects to assume. Upon receipt of such notice, Contractor shall promptly take all steps necessary to effect such assignment.

14.4 Conversion to Termination for Convenience. In the event that any termination of Contractor for cause under Section 14.3 is later determined to have been improper, the termination shall automatically convert to a termination for convenience under Section 14.5 and Contractor's recovery for termination shall be strictly limited to the payments allowable under Section 14.5.

14.5 Termination for Convenience of Owner. Owner reserves the right, without breach, to terminate the Contract prior to, or during the performance of the Work, for any reason. Upon such an occurrence, the following shall apply:

14.5.1 Owner will immediately notify Contractor and A/E in writing, specifying the reason for and the effective date of the Contract termination. Such notice may also contain instructions necessary for the protection, storage or decommissioning of incomplete work or systems, and for safety.

14.5.2 Upon receipt of the notice of termination, Contractor shall immediately proceed with the following obligations, regardless of any delay in determining or adjusting any amounts due at that point in the Contract:

14.5.2.1 Stop all work.

14.5.2.2 Place no further subcontracts or orders for materials or services.

14.5.2.3 Terminate all subcontracts for convenience.

14.5.2.4 Cancel all materials and equipment orders as applicable.

14.5.2.5 Take action that is necessary to protect and preserve all property related to the Contract which is in the possession of Contractor.

14.5.3 When the Contract is terminated for Owner's convenience, Contractor may recover from Owner payment for all Work executed. Contractor may not claim lost profits on other work or lost business opportunities.

- 14.6 Termination By Contractor. If the Work is stopped for a period of ninety (90) days under an order of any court or other public authority having jurisdiction, or as a result of an act of government, such as a declaration of a national emergency making materials unavailable, through no act or fault of Contractor or Subcontractor or their agents or employees or any other persons performing any of the Work under a contract with Contractor, then Contractor may, upon thirty (30) additional days written notice to ODR, terminate the Contract and recover from Owner payment for all Work executed, but not lost profits on other work or lost business opportunities. If the cause of the Work stoppage is removed prior to the end of the thirty (30) day notice period, Contractor may not terminate the Contract.
- 14.7 Settlement on Termination. When the Contract is terminated for any reason, at any time prior to one hundred eighty (180) days after the effective date of termination, Contractor shall submit a final termination settlement proposal to Owner based upon recoverable costs as provided under the Contract. If Contractor fails to submit the proposal within the time allowed, Owner may determine the amount due to Contractor because of the termination and pay the determined amount to Contractor.

Article 15. Dispute Resolution

- 15.1 Unresolved Contractor Disputes. The dispute resolution process provided for in Tex. Gov't Code, Ch. 2260, **and the procedures provided in Title 31, Part 2, Chapter 51, Subchapter J of the Texas Administrative** or Tex. Civ. Prac. & Rem. Code, Ch. 114, shall be used by Contractor to attempt to resolve any claim for breach of Contract made by Contractor that is not resolved under procedures described throughout the Uniform General Conditions, Supplementary Conditions, or Special Conditions of the Contract.
- 15.2 Alternative Dispute Resolution Process. Owner may establish a dispute resolution process to be utilized in advance of that outlined in Tex. Gov't Code, Ch. 2260 or Tex. Civ. Prac. & Rem. Code, Ch. 114.
- 15.3 Nothing herein shall hinder, prevent, or be construed as a waiver of Owner's right to seek redress on any disputed matter in a court of competent jurisdiction.
- 15.4 Nothing herein shall waive or be construed as a waiver of the State's sovereign immunity.

Article 16. Miscellaneous

- 16.1 Supplementary General and Special Conditions. When the Work contemplated by Owner is of such a character that the foregoing Uniform General Conditions of the Contract cannot adequately cover necessary and additional contractual relationships, the Contract may include Supplementary General and Special Conditions as described below:
- 16.1.1 Supplementary General Conditions may describe the standard procedures and requirements of contract administration followed by a contracting agency of the State. Supplementary General Conditions may expand upon matters covered by the Uniform General Conditions, where necessary, provided the expansion does not weaken the character or intent of the Uniform General Conditions. Supplementary General Conditions are of such a character that it is to be anticipated that a contracting agency of the State will normally use the same, or similar, conditions to supplement each of its several projects.
- 16.1.2 Special Conditions shall relate to a particular Project and be unique to that Project but shall not weaken the character or intent of the Uniform General Conditions.
- 16.2 Federally Funded Projects. On Federally funded projects, Owner may waive, suspend or modify any Article in these Uniform General Conditions which conflicts with any Federal statute, rule, regulation or procedure, where such waiver, suspension or modification is essential to receipt by Owner of such Federal funds for the Project. In the case of any Project wholly financed by Federal funds, any standards required by the enabling Federal statute, or any Federal rules, regulations or procedures adopted pursuant thereto, shall be controlling.
- 16.3 Internet-based Project Management Systems. At its option, Owner may administer its design and construction management through an Internet-based management system. In such cases, Contractor shall conduct communication through this media and perform all Project related functions utilizing this database system. This includes correspondence, submittals, Requests for Information, vouchers or payment requests and processing, amendment, Change Orders and other administrative activities.
- 16.3.1 Accessibility and Administration.
- 16.3.1.1 When used, Owner will make the software accessible via the Internet to all Project team members.
- 16.3.1.2 Owner shall administer the software.
- 16.3.2 Training. When used, Owner shall provide training to the Project team members.
- 16.4 Administrative Inspections and Audits. Contractor agrees that all relevant records related to this Contract or any work product under this Contract, including practices of

its Subcontractors, shall be subject, at any reasonable time, to inspection, examination, review, audit, and copying at any office or location of Contractor where such records may be found, with or without notice by the Texas State Auditor's Office ("SAO"), the contracting agency or its contracted examiners, or the Office of the Texas Attorney General, and with regard to any federal funding, the relevant federal agency, the Comptroller General, the General Accounting Office, the Office of the Inspector General, or any of their authorized representatives. All Subcontracts shall reflect the requirements of this section. In addition, pursuant to Tex. Gov't Code § 2262.003 the SAO may conduct an audit or investigation of any entity receiving funds under this Contract, including direct payments to Contractor and indirect payments under a Subcontract to this Contract; acceptance of such monies acts as acceptance of SAO authority, under legislative audit committee direction, to audit and investigate related to those funds and the entity subject to the audit or investigation must provide SAO with access to any information SAO considers relevant to the scope of the audit or investigation.

End of Uniform General Conditions

2018 SUPPLEMENTARY GENERAL CONDITIONS TO THE STATE OF TEXAS 2015 EDITION OF THE UNIFORM GENERAL CONDITIONS FOR CONSTRUCTION CONTRACTS

The following Supplementary General Conditions amend and/or supplement the 2015 edition of the Uniform General Conditions for Construction Contracts.

Article 5. Bonds and Insurance

5.2 Insurance Requirements.

Subsection 5.2.4 is supplemented to add the following new paragraphs:

- 5.2.4.1 Contractor shall deliver to Owner true and complete copies of the General Contractor's certificates prior to the issuance of any Notice to Proceed.
- 5.2.4.2 Failure of Owner to demand such certificates or other evidence of Contractor's full compliance with these insurance requirements or failure of Owner to identify a deficiency in compliance from the evidence provided shall not be construed as a waiver of Contractor's obligation to maintain such insurance.
- 5.2.4.3 The insurance and insurance limits required herein shall not be deemed as a limitation on Contractor's liability under the indemnities granted to Owner in the Contract Documents.
- 5.2.4.4 The insurance coverage and limits established in the Uniform General Conditions, Supplementary General Conditions, or Special Conditions shall not be interpreted as any representation or warranty that the insurance coverage and limits necessarily will be adequate to protect Contractor.

Article 2. Wage Rates and Other Laws Governing Construction

Add Section 2.7 as follows:

2.7 Buy America Requirements for Iron and Steel Used in Construction. In accordance with Texas Government Code 2252, Section 2252.202, all iron or steel products (i.e., rolled structural shapes including wide flange beams and columns, angles, bars, plates, sheets, hollow structural sections, pipe, etc.) shall be produced, manufactured and fabricated in the United States.

End of Supplementary General Conditions

TEXAS PARKS AND WILDLIFE

PREVAILING WAGE RATE DETERMINATION INFORMATION

Chapter 2258, Texas Government Code, Title 10 requires that state agencies, (including universities), cities, counties, independent school districts, and all other political subdivisions that engage in public works construction projects produce and include prevailing wage rate determinations in the project bidding and contract documents.

Chapter 2258 requires that the contractor who is awarded a contract by a public body and a contractor’s subcontractor shall pay not less than the rates determined by such state agencies to workers employed for the execution of such work. Pursuant to Chapter 2258, Texas Parks and Wildlife has ascertained the following wages to be paid for the various classifications of workers, in the locality of this project. In determining these wages, TPWD has utilized the Prevailing Wage Rates as determined by the U.S. DOL in accordance with the Davis-Bacon Act.

General Decision Number: TX20230144 10/13/2023

Superseded General Decision Number: TX20220144

State: Texas

Construction Type: Building

County: Gillespie County in Texas.

BUILDING CONSTRUCTION PROJECTS (does not include single family homes or apartments up to and including 4 stories).

Note: Contracts subject to the Davis-Bacon Act are generally required to pay at least the applicable minimum wage rate required under Executive Order 14026 or Executive Order 13658.

Please note that these Executive Orders apply to covered contracts entered into by the federal government that are subject to the Davis-Bacon Act itself, but do not apply to contracts subject only to the Davis-Bacon Related Acts, including those set forth at 29 CFR 5.1(a)(2)-(60).

If the contract is entered	Executive Order 14026
into on or after January 30,	generally applies to the
2022, or the contract is	contract.
renewed or extended (e.g., an	The contractor must pay
option is exercised) on or	all covered workers at
after January 30, 2022:	least \$16.20 per hour (or
	the applicable wage rate
	listed on this wage
	determination, if it is
	higher) for all hours
	spent performing on the

	contract in 2023.
If the contract was awarded on or between January 1, 2015 and January 29, 2022, and the contract is not renewed or extended on or after January 30, 2022:	Executive Order 13658 generally applies to the contract. The contractor must pay all covered workers at least \$12.15 per hour (or the applicable wage rate listed on this wage determination, if it is higher) for all hours spent performing on that contract in 2023.

The applicable Executive Order minimum wage rate will be adjusted annually. If this contract is covered by one of the Executive Orders and a classification considered necessary for performance of work on the contract does not appear on this wage determination, the contractor must still submit a conformance request.

Additional information on contractor requirements and worker protections under the Executive Orders is available at <http://www.dol.gov/whd/govcontracts>.

Modification Number	Publication Date
0	01/06/2023
1	01/27/2023
2	08/25/2023
3	10/13/2023

ASBE0087-002 06/04/2023

	Rates	Fringe
ASBESTOS WORKER/HEAT & FROST INSULATOR.....	\$ 28.95	8.39

* BOIL0531-001 01/01/2023

	Rates	Fringes
Boilermaker.....	\$ 37.00	24.64

* IRON0263-019 06/01/2023

	Rates	Fringes
Ironworker, reinforcing and structural.....	\$ 27.89	7.93

* LABO0154-001 05/01/2008

	Rates	Fringes
Laborers: (Mason Tender -Cement/Concrete)	\$ 12.98 **	3.49

PLUM0142-010 07/01/2023

	Rates	Fringes
PLUMBER, Excludes HVAC Pipe Installation.....	\$ 35.95	11.25

* SUTX2009-031 04/20/2009

	Rates	Fringes
BRICKLAYER.....	\$ 19.67	0.00
CARPENTER, Includes Acoustical Ceiling Installation, Drywall Hanging, and Metal Stud Installation.....	\$ 13.13 **	0.00
CEMENT MASON/CONCRETE FINISHER.....	\$ 13.27 **	0.00
ELECTRICIAN.....	\$ 20.00	3.11
GLAZIER.....	\$ 17.20	1.59
HVAC MECHANIC (HVAC Duct and Pipe Installation)	\$ 14.21 **	0.77
INSTALLER - OVERHEAD DOOR.....	\$ 11.63 **	6.26
LABORER: Common or General.....	\$ 9.73 **	0.00
LABORER: Landscape & Irrigation.....	\$ 8.50 **	0.22
LABORER: Mason Tender - Brick.....	\$ 12.02 **	0.00
LABORER: Mortar Mixer.....	\$ 12.00 **	0.00
LABORER: Plaster Tender.....	\$ 9.00 **	0.00
OPERATOR: Backhoe/Excavator/Trackhoe.....	\$ 13.75 **	0.00
OPERATOR: Bulldozer.....	\$ 12.80 **	0.43
OPERATOR: Crane.....	\$ 21.33	0.00
OPERATOR: Forklift.....	\$ 14.58 **	0.00
OPERATOR: Loader (Front End)	\$ 10.54 **	0.00
PAINTER: Brush, Roller and Spray.....	\$ 12.26 **	0.00
PLASTERER.....	\$ 15.50 **	0.00
ROOFER.....	\$ 13.64 **	1.80
SHEET METAL WORKER, Excludes HVAC Duct Installation...\$	17.00	0.00
TILE SETTER.....	\$ 15.00 **	0.00
TRUCK DRIVER.....	\$ 11.24 **	0.35

WELDERS - Receive rate prescribed for craft performing operation to which welding

is incidental.

=====
** Workers in this classification may be entitled to a higher minimum wage under Executive Order 14026 (\$16.20) or 13658 (\$12.15). Please see the Note at the top of the wage determination for more information.

Note: Executive Order (EO) 13706, Establishing Paid Sick Leave for Federal Contractors applies to all contracts subject to the Davis-Bacon Act for which the contract is awarded (and any solicitation was issued) on or after January 1, 2017. If this contract is covered by the EO, the contractor must provide employees with 1 hour of paid sick leave for every 30 hours they work, up to 56 hours of paid sick leave each year. Employees must be permitted to use paid sick leave for their own illness, injury or other health-related needs, including preventive care; to assist a family member (or person who is like family to the employee) who is ill, injured, or has other health-related needs, including preventive care; or for reasons resulting from, or to assist a family member (or person who is like family to the employee) who is a victim of, domestic violence, sexual assault, or stalking. Additional information on contractor requirements and worker protections under the EO is available at <https://www.dol.gov/agencies/whd/government-contracts>.

Unlisted classifications needed for work not included within the scope of the classifications listed may be added after award only as provided in the labor standards contract clauses (29CFR 5.5 (a) (1) (ii)).

The body of each wage determination lists the classification and wage rates that have been found to be prevailing for the cited type(s) of construction in the area covered by the wage determination. The classifications are listed in alphabetical order of ""identifiers"" that indicate whether the particular rate is a union rate (current union negotiated rate for local), a survey rate (weighted average rate) or a union average rate (weighted union average rate).

Union Rate Identifiers

A four letter classification abbreviation identifier enclosed in dotted lines beginning with characters other than ""SU"" or ""UAVG"" denotes that the union classification and rate were prevailing for that classification in the survey. Example: PLUM0198-005 07/01/2014. PLUM is an abbreviation identifier of the union which prevailed in the survey for this classification, which in this example would be Plumbers. 0198 indicates the local union number or district council number where applicable, i.e., Plumbers Local 0198. The next number, 005 in the example, is an internal number used in processing the wage determination. 07/01/2014 is the effective date of the most current negotiated rate, which in this example is July 1, 2014.

Union prevailing wage rates are updated to reflect all rate changes in the collective bargaining agreement (CBA) governing this classification and rate.

Survey Rate Identifiers

Classifications listed under the ""SU"" identifier indicate that no one rate prevailed for this classification in the survey and the published rate is derived by computing a weighted average rate based on all the rates reported in the survey for that classification. As this weighted average rate includes all rates reported in the survey, it may include both union and non-union rates. Example: SULA2012-007 5/13/2014. SU indicates the rates are survey rates based on a weighted average calculation of rates and are not majority rates. LA indicates the State of Louisiana. 2012 is the year of survey on which these classifications and rates are based. The next number, 007 in the example, is an internal number used in producing the wage determination. 5/13/2014 indicates the survey completion date for the classifications and rates under that identifier.

Survey wage rates are not updated and remain in effect until a new survey is conducted.

Union Average Rate Identifiers

Classification(s) listed under the UAVG identifier indicate that no single majority rate prevailed for those classifications; however, 100% of the data reported for the Classifications was union data. EXAMPLE: UAVG-OH-0010 08/29/2014. UAVG indicates that the rate is a weighted union average rate. OH indicates the state. The next number, 0010 in the example, is an internal number used in producing the wage determination. 08/29/2014 indicates the survey completion date for the classifications and rates under that identifier. A UAVG rate will be updated once a year, usually in January of each year, to reflect a weighted average of the current negotiated/CBA rate of the union locals from which the rate is based.

WAGE DETERMINATION APPEALS PROCESS

1.) Has there been an initial decision in the matter? This can be:

- * an existing published wage determination
- * a survey underlying a wage determination
- * a Wage and Hour Division letter setting forth a position on a wage determination matter
- * a conformance (additional classification and rate) ruling

On survey related matters, initial contact, including requests for summaries of surveys, should be with the Wage and Hour National Office because National Office has responsibility for the Davis-Bacon survey program. If the response from this initial contact is not satisfactory, then the process described in 2.) and 3.) should be followed.

With regard to any other matter not yet ripe for the formal process described here, initial contact should be with the Branch of Construction Wage Determinations. Write to:

Branch of Construction Wage Determinations
Wage and Hour Division
U.S. Department of Labor
200 Constitution Avenue, N.W.
Washington, DC 20210

2.) If the answer to the question in 1.) is yes, then an interested party (those affected by the action) can request review and reconsideration from the Wage and Hour Administrator (See 29 CFR Part 1.8 and 29 CFR Part 7). Write to:

Wage and Hour Administrator
U.S. Department of Labor
200 Constitution Avenue, N.W.
Washington, DC 20210

The request should be accompanied by a full statement of the interested party's position and by any information (wage payment data, project description, area practice material, etc.) that the requestor considers relevant to the issue.

3.) If the decision of the Administrator is not favorable, an interested party may appeal directly to the Administrative Review Board (formerly the Wage Appeals Board). Write to:

Administrative Review Board
U.S. Department of Labor
200 Constitution Avenue, N.W.
Washington, DC 20210

4.) All decisions by the Administrative Review Board are final.

=====

END OF GENERAL DECISION

TEXAS PARKS AND WILDLIFE

AGREEMENT BETWEEN OWNER AND CONTRACTOR

STATE OF TEXAS

COUNTY OF TRAVIS

THIS AGREEMENT made this _____ day of _____, 20__ by and between the STATE OF TEXAS, acting through the **TEXAS PARKS AND WILDLIFE DEPARTMENT**, hereinafter called the OWNER, and **INSERT CONTRACTOR COMPANY NAME**, hereinafter called the CONTRACTOR.

WITNESSETH: That for and in consideration of the payments and agreements hereinafter described, to be made and performed by the OWNER, the CONTRACTOR hereby agrees with the OWNER to commence and complete certain public works described as: **Danz Cabins Repairs at LBJ State Park and Historic Site, Stonewall, Texas, Gillespie County, Texas**, for the use and benefit of the OWNER as described in the Invitation for Bids and Contract Documents prepared by TEXAS PARKS AND WILDLIFE DEPARTMENT. Contract Documents include all parts of this Invitation for Bids, including but not limited to, Specifications, Scope of Work, the Special Conditions, Supplementary General Conditions, and Uniform General Conditions, for **Project Number CR11387R**. The Contract Documents are hereby incorporated by reference into this **Contract Number TBD / Purchase Order No TBD**.

In the event that there is a conflict, this contract and its attachments take priority over all other documents. Following the contract in order of priority are **the Special Conditions, Supplementary General Conditions, Uniform General Conditions, Invitation for Bids and Contract Documents, and Contractor's Bid**.

The consideration to be paid by the OWNER to the CONTRACTOR for furnishing all the materials, supplies, machinery, equipment, tools, labor, superintendence, insurance, and other accessories and services necessary to complete the said Project in accordance with the Contract Documents is the not to exceed amount of **INSERT AMOUNT Dollars and No Cents (\$xxx,xxx.xx)**. **Include which base bid/alternate/options, allowances make up the award.**

Any alterations, additions, or deletions to the terms of the contract that are required by changes in federal or state law or regulations are automatically incorporated into the contract without written amendment hereto and shall become effective on the date designated by such law or by regulation.

The CONTRACTOR hereby agrees to complete all work within **one hundred eighty (180)** calendar days, commencing on the date specified in OWNER'S written "Notice to Proceed." Time is of the essence with this contract.

Payments by OWNER shall be warrants issued by the Comptroller of Public Accounts out of monies appropriated to the Texas Parks and Wildlife Department for such purpose and shall be made upon OWNER'S acceptance of all portions of work as prescribed in the Specifications.

Subject to Texas Government Code, Section 2260.002, the dispute resolution process provided for in Chapter 2260 of the Texas Government Code and set forth below in subsections (a)-(d) shall be used by the parties to attempt to resolve all disputes arising under this contract. In accordance with the Texas Civil Practice and Remedies Code, Section 114.005, the parties agree claims encompassed by Texas Government Code, Section 2260.002(3) and Texas Civil Practice and Remedies Code Section 114.002 shall be governed by the dispute resolution process set forth below in subsections (a)-(d).

(a) Notwithstanding Texas Government Code, Chapter 2260.002(3) and Chapter 114.012 and any other statute or applicable law, if the Respondent's claim for breach of contract cannot be resolved by the parties in the ordinary course of business, Respondent may make a claim against Agency for breach of contract and the Agency may assert a counterclaim against the Respondent as is contemplated by Texas Government Code, Chapter 2260, Subchapter B. In such event, Respondent must provide written notice to Agency of a claim for breach of the contract not later than the 180th day after the date of the event giving rise to the claim.

The notice must state with particularity:

- (1) the nature of the alleged breach;
- (2) the amount the Respondent seeks as damages; and
- (3) the legal theory of recovery.

(b) The chief administrative officer, or if designated in the contract, another officer of the Agency, shall examine the claim and any counterclaim and negotiate with the Respondent in an effort to resolve them. The negotiation must begin no later than the 120th day after the date the claim is received, as is contemplated by Texas Government Code, Chapter 2260, Section 2260.052.

(c) If the negotiation under paragraph (b) above results in the resolution of some disputed issues by agreement or in a settlement, the parties shall reduce the agreement or settlement to writing and each party shall sign the agreement or settlement. A partial settlement or resolution of a claim does not waive a party's rights under this contract as to the parts of the claim that are not resolved.

(d) If a claim is not entirely resolved under paragraph (b) above, on or before the 270th day after the date the claim is filed with Agency, unless the parties agree in writing to an extension of time, the parties may agree to mediate a claim made under this dispute resolution procedure. This dispute resolution procedure is the Respondent's sole and exclusive process for seeking a remedy for an alleged breach of contract by the Agency if the parties are unable to resolve their disputes as described in this section.

(e) Nothing in the contract shall be construed as a waiver of the states or the Agency's sovereign immunity.

This contract shall not constitute or be construed as a waiver of any of the privileges, rights, defenses, remedies, or immunities available to the State of Texas. The failure to enforce, or any delay in the enforcement, of any privileges, rights, defenses, remedies, or immunities available to the State of Texas under this contract or under applicable law shall not constitute a waiver of such privileges, rights, defenses, remedies or immunities or be considered as a basis for estoppel.

Agency does not waive any privileges, rights, defenses, or immunities available to Agency by entering into this contract or by its conduct, or by the conduct of any representative of Agency, prior to or subsequent to entering into this contract.

(f) Compliance with the dispute resolution process provided for in Texas Government Code, Chapter 2260, subchapter B and incorporated by reference in subsection (a)-(d) above is a condition precedent to the

Respondent:

- (1) filing suit pursuant to Chapter 114 of the Civil Practices and Remedies Code; or
- (2) initiating a contested case hearing pursuant to Subchapter C of Chapter 2260 of the Texas Government Code.

Notices. Notices of claims or disputes or other legal notices required by this Agreement shall be sent to the following persons at the indicated locations.

If to Owner: Misty K. Wyatt, CTCD, CTCM, Contract Manager
misty.wyatt@tpwd.texas.gov

With Copies to: John Damen, Construction Project Manager
john.damen@tpwd.texas.gov

Todd George, Attorney, Legal Division
Texas Parks and Wildlife Department
4200 Smith School Road
Austin, Texas 78744

If to Contractor:

Name _____

Company Name _____

Address _____

Address _____

Email _____

Phone No. _____

The parties may make reasonable changes in the person or place designated for receipt of notices upon advance written notice to the other party.

Party Representatives. The Owner's Designated Representative authorized to act in the Owner's behalf with respect to the Project is:

John Damen, Construction Project Manager
Email: john.damen@tpwd.texas.gov

The Contractor's designated representative authorized to act on the Contractor's behalf and bind the Contractor with respect to the Project is:

Name _____
Company Name _____
Address _____
Address _____
Email _____
Phone No. _____

The parties may make reasonable changes in their designated representatives upon advance written notice to the other party.

The contract shall be governed by and construed in accordance with the laws of the State of Texas, without regard to the conflicts of law provisions. The venue of any suit arising under the Contract is fixed in any court of competent jurisdiction in Travis County, Texas unless the specific venue is otherwise identified in a statute which directly names or otherwise identifies its applicability to the contracting agency. All payments under this Contract shall be due and payable in Travis County, Texas.

The Contractor hereby assigns to Owner any and all claims for overcharges associated with this Contract which arise under the antitrust laws of the United States 15 U.S.C.A. SEC. 1 et. seq. (1973).

This Agreement is subject to cancellation, without penalty, either in whole or in part, if funds are not appropriated by the Texas Legislature or otherwise made available to the Texas Parks and Wildlife Department for the specified services under this Agreement.

The said parties for themselves, their heirs, successors, executors, administrators, and assigns, do hereby agree to full performance of the covenants herein contained.

IN WITNESS WHEREOF, the parties to these presents have executed this Contract in two (2) counterparts, each of which shall be deemed an original, in the day and year first above written.

Signatures follow on the next page.

Contractor:

By: _____ **Date** _____

Title: _____

Owner: Texas Parks and Wildlife Department

By: _____ **Date** _____

Title: _____

DRAFT

TEXAS PARKS AND WILDLIFE

PERFORMANCE BOND

STATE OF TEXAS

Project Number CR11387R

COUNTY OF _____

Contract Number TBD

KNOW ALL MEN BY THESE PRESENTS:

That we, _____, as **PRINCIPAL**,

and _____, as **SURETY(IES)**,

Surety Address: _____ Surety Phone: _____ Surety Fax: _____

are hereby held and firmly bound unto the State of Texas in the penal sum of:

_____ Dollars (\$ _____)

for the payment, whereof, the said **PRINCIPAL** and **SURETY(IES)** bind themselves, their heirs, executors, administrators, and successors, jointly and severally, firmly by these presents.

The conditions of this obligation are such that whereas the **PRINCIPAL** entered into a certain contract dated _____, 20____, hereto attached, and made a part hereof, with the State of Texas, acting by and through the Texas Parks and Wildlife Department, to commence and complete certain public works described as:

Danz Cabins Repairs, Lyndon B. Johnson State Park and Historic Site, Stonewall, Gillespie, Texas

NOW THEREFORE, the conditions of this obligation are such that, if the **PRINCIPAL** shall faithfully perform the contract in accordance with the plans, specifications, and contract documents, and as provided in TITLE 10, TEXAS GOVERNMENT CODE, CHAPTER 2253 shall fully indemnify and save harmless the State of Texas from all cost and damage which the State of Texas may suffer by reason of the **PRINCIPAL'S** default or failure to do so and shall fully reimburse and repay the State of Texas all outlay and expense which the State of Texas may incur in making good any such default, then obligation shall be null and void, otherwise it shall remain in full force and effect.

Provided further, that if any legal action be filed upon this bond, venue shall lie in Travis County, Texas and that the said surety(ies) for value received, hereby stipulates and agrees that no change, extension of time, alteration or addition to the terms of the Contract, or to the work to be performed thereunder, or the Specifications accompanying the same, shall in anywise affect its obligation on this bond, and it does hereby waive notice of any such change, extension of time, alternation or addition, to the items of the Contract or to the work or to the Specifications.

In the event **PRINCIPAL** is in default under the contract as defined herein, **SURETY(IES)** will within fifteen (15) days of determination of such default take over and assume completion of said contract and become entitled to the payment of the balance of the contract price.

IN WITNESS WHEREOF, the above bound parties have executed this instrument under their several seals this _____ day of _____, 20____, the name and corporation seal of each corporate party being hereto affixed and these presents duly signed by its undersigned representative pursuant to authority of its governing body.

PRINCIPAL

SURETY

BY _____

BY _____

TEXAS PARKS AND WILDLIFE

PAYMENT BOND

STATE OF TEXAS

Project Number CR11387R

COUNTY OF _____

Contract Number TBD

KNOW ALL MEN BY THESE PRESENTS:

That we, _____, as **PRINCIPAL**,
and _____, as **SURETY(IES)**,

Surety Address: _____ Surety Phone: _____ Surety Fax: _____

are hereby held and firmly bound unto the State of Texas in the penal sum of: _____ Dollars (\$ _____) for the payment, whereof, the said **PRINCIPAL** and **SURETY(IES)** bind themselves, their heirs, executors, administrators, successors, and assigns jointly and severally, firmly by these presents.

The conditions of this obligation are such that whereas the **PRINCIPAL** entered into a certain contract dated _____, 20__, hereto attached, and made a part hereof, with the State of Texas, acting by and through the Texas Parks and Wildlife Department, to commence and complete certain public works described as:
Danz Cabins Repairs, Lyndon B. Johnson State Park and Historic Site, Stonewall, Gillespie, Texas

NOW THEREFORE, the conditions of this obligation are such that, if the **PRINCIPAL** shall promptly make payment to all claimants as defined in TITLE 10, *TEXAS GOVERNMENT CODE*, CHAPTER 2253, as amended, supplying labor and materials in the prosecution of the work provided for in said contract and any and all duly authorized changes to said contract that may hereafter be made, notice of such changes to the **SURETY(IES)** being hereby waived, then, this obligation shall be null and void, otherwise it shall remain in full force and effect.

This bond is made and entered into solely for the protection of all claimants supplying labor and materials in the prosecution of the work provided for in said contract, and all such claimants shall have a direct right to action under the bond as provided in TITLE 10, *TEXAS GOVERNMENT CODE*, CHAPTER 2253, as amended.

IN WITNESS WHEREOF, the above bound parties have executed this instrument under their several seals this _____ day of _____, 20__, the name and corporation seal of each corporate party being hereto affixed and these presents duly signed by its undersigned representative pursuant to authority of its governing body.

PRINCIPAL

SURETY

BY _____

BY _____

TEXAS PARKS AND WILDLIFE

CONTRACTOR'S PROGRESS PAYMENT AFFIDAVIT

STATE OF TEXAS

PROJECT NUMBER CR11387R

COUNTY OF _____

CONTRACT NUMBER TBD

BEFORE ME THE UNDERSIGNED AUTHORITY, on this day personally appeared the Affiant named below who being duly sworn, on oath, says that he/she is a duly authorized representative of the company named below; and that all terms of the Contract for the completion of certain public works described as **Project No. CR11387R, Danz Cabins Repairs at Lyndon B. Johnson State Park and Historic Site, Gillespie County, Texas** have been satisfactorily completed to the extent indicated on the attached voucher and that ALL sums of money due for payrolls, bills for material and equipment, and other indebtedness connected with the Work for which OWNER or its property might in any way be responsible, to the best of his/her knowledge and belief have been paid or will be paid or otherwise satisfied within ten days after receipt of the requested payment from the OWNER, or within the period of time required by Title 10, Texas Government Code, Section 2251.022.

Affiant	Title	Company

Affiant agrees to indemnify and hold Owner harmless from any liens, debts or obligations which arise as a result of labor or materials provided by or through Affiant to the project. Affiant further agrees to indemnify and hold harmless all real property on which the improvements were constructed and all interests in such property, including leasehold interests, from any liens, debts, or obligations arising from any labor or materials provided by or through Affiant to the project.

Payments to subcontractors for labor and/or materials which are pending or disputed as of the date hereof are:

<u>Individual or Company Name</u>	<u>Mailing Address</u>	<u>Amount Owed</u>
_____	_____	_____
_____	_____	_____
_____	_____	_____

INSTRUCTIONS: Affidavit must be signed by an individual owner, or partner in a partnership, or by a person authorized by bylaws or Board of Directors to sign for a corporation. If Contractor is a joint venture or partnership of individuals, either may sign, but if a joint venture in which a corporation is a party, separate affidavits must be executed by each corporation and by each individual owner or partnership.

Affiant Signature

Sworn to and subscribed before this _____ day of _____, 20_____

(SEAL)

Notary Public in and for _____ County, TX

CONTRACTOR'S FINAL PAYMENT AFFIDAVIT

STATE OF TEXAS
COUNTY OF _____

PROJECT NUMBER CR11387R
CONTRACT NUMBER TBD

BEFORE ME THE UNDERSIGNED AUTHORITY, on this day personally appeared the Affiant named below who being duly sworn, on oath, says that he/she is a duly authorized representative of the company named below; and that all terms of the Contract for the completion of certain public works described as **Project No. CR11387R, Danz Cabins Repairs at Lyndon B. Johnson State Park and Historic Site, Gillespie County, Texas** have been satisfactorily completed and that ALL sums of money for payrolls, bills for material and equipment, and other indebtedness connected with the Work for which Owner or its property might in any way be responsible, to the best of his/her knowledge and belief, have been paid or will be paid or otherwise satisfied within ten days after receipt of final payment from the Owner, or within the period of time required by Title 10, Texas Government Code, Section 2251.022.

Affiant	Title	Company

Payments not made in full at the date of this affidavit are listed below. Affiant hereby waives all claims against the Owner. (List any exceptions):

Affiant agrees to indemnify and hold Owner harmless from any liens, debts or obligations which arise as a result of labor or materials provided by or through Affiant to the project. Affiant further agrees to indemnify and hold harmless all real property on which the improvements were constructed and all interests in such property, including leasehold interests, from any liens, debts, or obligations arising from any labor or materials provided by or through Affiant to the project.

Final payments to subcontractors for labor and/or materials which are pending or disputed as of the date hereof are:

<u>Individual or Company Name</u>	<u>Mailing Address</u>	<u>Amount Owed</u>
_____	_____	_____
_____	_____	_____
_____	_____	_____

INSTRUCTIONS: Affidavit must be signed by an individual owner, or partner in a partnership, or by a person authorized by bylaws or Board of Directors to sign for a corporation. If Contractor is a joint venture or partnership of individuals, either may sign, but if a joint venture in which a corporation is a party, separate affidavits must be executed by each corporation and by each individual owner or partnership. In the event subcontractors, laborers, or materialmen have not been paid in full, Contractor shall list hereon the amount owed and the name and address of each subcontractor, laborer, or materialman to whom such payment is owed. Add additional pages if required.

Affiant Signature

Sworn to and subscribed before this _____ day of _____, 20_____

(SEAL)

Notary Public in and for _____ County, TX

TEXAS PARKS AND WILDLIFE

CONSENT OF SURETY COMPANY TO FINAL PAYMENT

PROJECT	CR11387R
TITLE OF PROJECT	Danz Cabins Repairs
PROJECT LOCATION	Lyndon B. Johnson State Park and Historic Site
CONTRACT NO	TBD
CONTRACT DATE	TBD

OWNER: Texas Parks and Wildlife Department
4200 Smith School Road
Austin, Texas 78744

CONTRACTOR: Name _____
Address _____
City, State, Zip _____
Code _____

SURETY COMPANY: Name _____
Address _____
City, State, Zip _____
Code _____

on bond of _____, Contractor, hereby approves of the final payment by Owner to Contractor on the above Contract and agrees that final payment to the Contractor shall not relieve Surety Company of any of its obligations to Owner as set forth in said Surety Company's bond.

IN WITNESS WHEREOF, Surety Company has hereunto set its hand this _____ day of _____, 20____

SURETY COMPANY:

By _____

Signature _____

Printed Name _____

Title _____

**NON-USE OF ASBESTOS CONTAINING MATERIALS AFFIDAVIT -
CONTRACTOR**

STATE OF TEXAS §

COUNTY OF _____ §

Project Number: CR11387R
Project Name: Danz Cabins Repairs
Project Location: Lyndon B. Johnson State Park and Historic Site

By the signature below, the signatory for the Contractor certifies that neither he nor the firm, corporation, partnership or institution represented by the signatory or anyone acting for the firm providing Construction Services for this project, including Subcontractors, have utilized materials, procedures or processes that knowingly or intentionally contain asbestos materials.

Signature: _____
Printed Name: _____
Title: _____
Company: _____
Date: _____

State of Texas
County of _____

Sworn to and subscribed before me on the _____ day of _____, 20__ by _____
(name/signature of signer) the undersigned authority on behalf of said Contractor.

(Personalized Seal)

Notary Public's Signature

My commission expires: _____

REMOTE VIRTUAL INSPECTION AGREEMENT

Project Number: _____ Project Name: _____

Remote Virtual Inspections (RVIs) are recognized by the International Code Council (ICC) as a form of visual inspection which uses visual or electronic aids to allow an inspector or team of inspectors to observe products and/or materials from a distance.¹ The Infrastructure Division of the Texas Parks and Wildlife Department (TPWD) recognizes that the use of RVIs is an accepted practice that promotes efficiency by allowing TPWD Inspectors to remotely observe products, materials, and building practices while promoting cost savings.

The use of RVIs will be at the sole discretion of TPWD. When the general contractor (GC) requests an inspection, TPWD will determine whether a RVI or onsite inspection shall be utilized. Onsite inspections are required for Substantial Completion and Final Completion inspections. RVIs require reliable Internet connection (Wi-Fi or cellular).

RVIs shall be conducted by the GC sharing live video footage of the project site through a web-enabled device (smartphone, tablet, laptop, etc.) using a virtual meeting application designed by TPWD (e.g. Microsoft Teams). The TPWD Inspector shall attend the virtual meeting and conduct the inspection by viewing the live video footage provided by the GC of the relevant materials and/or areas of work that is the subject of the inspection. TPWD will capture images and/or video of the project site provided by the GC for archiving and inspection reporting. The TPWD Inspector will act as the witness to the inspection and sign the applicable documentation confirming the inspection has taken place. TPWD staff other than the TPWD Inspector may attend the RVI virtual meeting to observe the inspection.

The GC shall comply with the following requirements for RVIs:

- Ensure that the project site is safe at all times for the individual(s) using the device during the RVI.
- The device with a camera and microphone shall be fully charged and has a charged additional power supply (e.g. battery pack) prior to the RVI.
- The GC shall grant TPWD access to the device's camera, microphone, and device location at all times during the RVI.
- The project site must have high-speed Wi-Fi connectivity or minimum 4G cellular service with a strong signal.
- Site plans must be onsite and in a place that can be easily accessed by the GC during the RVI.
- The tools necessary to gain access to, provide ample visibility of, and/or are necessary for the RVI, must be available to the GC during the RVI including, but not limited to:
 - Tape measure, flashlight, level, step ladder, PPE, extending pole for the device, or
 - Any other tools or devices that are necessary for the RVI (e.g. GFCI tester).

¹ See http://media.iccsafe.org/2020_MarComm/Remote_Video_Insp_FINAL_w_Covers.pdf

The GC acknowledges that this Remote Visual Inspection Agreement (Agreement) is in addition to any other applicable contract documents for the above-referenced project name and number and that the terms and conditions of any other applicable contract documents are not modified by this Agreement and continue to apply.

The GC agrees to indemnify and hold harmless TPWD and its employees, officers, and directors for any liability associated with any RVI conducted pursuant to this Agreement.

The terms and conditions of this Agreement are agreed to and accepted by:

General Contractor

Date

TPWD Designated Representative

Date

DRAFT

CONSTRUCTION DOCUMENTS

DIVISION 1 – GENERAL REQUIREMENTS

SECTION 01000 – SPECIAL CONDITIONS

PART 1 – GENERAL

1.01 RELATED DOCUMENTS:

Drawings and general provisions of Contract, including Uniform General and Supplementary General Conditions and other Division 1 specification sections, apply to work of this section.

1.02 DESCRIPTION OF WORK:

Furnish all labor, materials, tools, equipment and incidentals necessary for performance of all work associated with Project information below, such work being as more particularly described in these Special Conditions, the drawings, and elsewhere in these Invitation for Bids and Contract Documents.

Project No.	CR11387R
Project Location	LBJ State Park and Historic Site
Project Title	Danz Cabins Repairs

1.03 INTENT OF THE CONTRACT DOCUMENTS: **(See also UGC, Article 6)**

- A. The intent of the Contract Documents is to include all of the work for the contract price and within the contract time. Contract Documents are to be considered as cooperative. All work not specified and/or not shown on the drawings, but which is necessary for the completion and/or functioning and operation of the project, shall be understood and implied as part of the contract to be performed by the Contractor for the contract price. Such work shall be executed by the Contractor in the same manner and with the same character of material as other portions of the contract without extra compensation.
- B. It is the intention of the Contract Documents to call for finished work, tested, and ready for operation.
 - 1. Any apparatus, material or work described in the Contract Documents and any incidental accessories necessary to make the work complete in all respects and ready for operation (even though not particularly specified) shall be furnished, delivered, and installed by the Contractor without additional expense to the Owner.
 - 2. Minor details not usually shown or specified but necessary for proper installation and operation are included in the work just as if herein specified or shown.

- C. All work shall be performed and furnished by the Contractor in accordance with accepted construction industry practices.
- D. A duplication of work is not intended by the Contract Documents and any duplication shall not become a basis for extra cost to the Owner.
- E. Explanatory notes on the drawings shall take precedence over conflicting drawn-out indications. Figured dimensions on drawings shall take precedence over scale measurements. Where figures are lacking, scale measurements may be followed, but in all cases the measurements are to be checked from the work in place and those measured dimensions taken at the site shall take precedence over scale dimensions in drawings.
- F. Upon discovery by Contractor of errors, omissions or inconsistencies in the Contract Documents, Contractor shall promptly report them to the Owner and shall wait for instruction from Owner prior to proceeding with the work.
- G. In the event of conflict between the Special Conditions, the Supplementary Conditions, and the Uniform General Conditions, the following priority order shall apply in resolving such conflicts: Special Conditions, Supplementary Conditions, and then Uniform General Conditions.
- H. The drawings consist of all project drawings and any drawings issued by addenda.

1.04 **Reserved**

1.05 SUBMITTAL REVIEW AND PROCESSING: (Refer also to UGC, Article 8)

A. GENERAL

1. A TPWD standard *Submittal Cover Sheet* must accompany each numbered submittal set. **One Submittal per Submittal Cover Sheet.**
2. The number of copies of submittals required for each item shall be not less than one (1) electronic copy, unless specified otherwise, for Owner's use, plus the number of additional copies that the Contractor desires for his own use.
3. The Contractor must double-check and sign all submittals before forwarding them to the Owner for review and action.
4. The Architect/Engineer and the Owner will review the submittal data. If there are no exceptions taken to the submittal, the original will be retained by the Owner. The Contractor must keep one copy at the jobsite at all times.

5. Any and all costs, direct or indirect, incurred by Owner in reviewing submittals in excess of two (2) times will be charged to the Contractor and deducted from the total price for the Work.
6. Owner's approval of shop drawings and/or any aspects of the Work shall not act to transfer Contractor's responsibility for, nor relieve Contractor from the performance of any of Contractor's duties set forth in the contract documents.
7. Contractor's failure to obtain approval of submittals will not constitute grounds for additional time. Owner will provide more specific clarification regarding the requirements for each Submittal.

1.06 CONTRACT COMPLETION: **(See also UGC, Article 9)**

- A. Unless specifically stated as "working day," the term "day" or "calendar day" shall mean every day of the calendar year. Along with the Work Progress Schedule, the Contractor shall submit his schedule for normal working days.
- B. **Liquidated Damages:** The Owner has determined that the completion of the work in this contract is critical to the proper operation of the facility, and the Contractor's failure to complete the work within such time will cause damage to the Owner. Since exact damages are difficult to determine or forecast, the sum of **\$339.22** per calendar day is hereby established by the parties as a reasonable estimate of just compensation to the Owner for the failure of the Contractor to complete the work by the time set forth in the contract or authorized extension thereto. Said sum will be deducted from the money due or to become due to the Contractor, not as a penalty but as liquidated damages from added expense, including administrative and inspection costs, for each and every calendar day the work or any portion thereof remains incomplete after the expiration of the time limit set in the contract or authorized extension.
- C. Charges for liquidated damages will begin accumulating on the first calendar day following the final contract completion date and continue until the date of final acceptance as established by the Owner. Final acceptance will not be issued until all punch list items have been completed.
- D. Expiration or termination of the contract for any reason does not release Respondent from any liability or obligation set forth in the contract that is expressly stated to survive any such expiration or termination, that by its nature would be intended to be applicable following any such expiration or termination, or that is necessary to fulfill the essential purpose of the contract, including without limitation the provisions regarding warranty, indemnification, confidentiality, and rights and remedies upon termination.

1.07 SPECIAL INSURANCE REQUIREMENTS: **(See also UGC, Article 5)**

- A. **Builder's Risk** (or Installation Floater for Equipment Installation Only): Builder's Risk is a requirement of this Invitation for Bids and Contract Documents.
- B. **Windstorm Coverage:** For those properties located within a Tier 1 or 2 windstorm area, named storm coverage must be provided limits shall be equal to 100 percent of the Contract Sum.
- C. **Flood Prone Areas:** For those properties located in flood prone areas, flood insurance coverage must be provided with limits shall be equal to 100 percent of the Contract Sum.

1.08. REFERENCES AND STANDARDS:

All contractors, including sub-contractors shall ensure all personnel follow the adopted Standardized Building Codes in all design and construction work.

1.09 NON-APPROPRIATION OF FUNDS:

The contract is subject to termination or cancellation, without penalty to TPWD, either in whole or in part, subject to the availability of state funds. TPWD is a state agency whose authority and appropriations are subject to actions of the Texas Legislature. If TPWD becomes subject to a legislative change, revocation of statutory authority, or lack of appropriated funds which would render TPWD's or contractor's delivery or performance under the contract impossible or unnecessary, the contract will be terminated or cancelled and be deemed null and void. In the event of a termination or cancellation under this Section, TPWD will not be liable to contractor for any damages, which are caused or associated with such termination, or cancellation and TPWD will not be required to give prior notice.

1.10 ANTIQUITIES:

Contractor shall take precaution to avoid disturbing primitive records and antiquities of archaeological, paleontological or historical significance. No objects of this nature shall be disturbed without written permission of Owner and the Texas Historical Commission. When such objects are uncovered unexpectedly, the Contractor shall stop all Work in close proximity and notify the ODR and the Texas Historical Commission of their presence and shall not disturb them until written permission and permit to do so is granted. All primitive rights and antiquities, as defined in Chapter 191, Texas Natural Resource Code, discovered on the Owner's property shall remain property of State of Texas, the Texas Historical Commission. It is determined by Owner, in consultation with the Texas Historical Commission that exploration or excavation of primitive records or antiquities on Project Site is necessary to avoid loss, Contractor shall cooperate in salvage work attendant to preservation.

1.11 PROPRIETARY OR CONFIDENTIAL INFORMATION; TEXAS PUBLIC INFORMATION ACT:

- A. Any proprietary, trade secret or otherwise confidential information Bidder includes in its Bid must be clearly labeled as proprietary or confidential information, and Bidder must identify the specific exception to disclosure in the Public Information Act (PIA). Merely making a blanket claim the entire Bid is protected from disclosure because it contains some proprietary information is not acceptable and shall make the entire Bid subject to release under the PIA. In order for the Owner to initial the process of seeking an Attorney General opinion on the release of proprietary or confidential information, the specific provisions of the Bid that are considered by the Bidder to be proprietary or confidential must be clearly labeled as described herein. Any information which is not clearly identified as proprietary or confidential shall be deemed to be subject to disclosure pursuant to the PIA.
- B. Information, documentation, and other material in connection with this solicitation or any resulting contract may be subject to public disclosure pursuant to Chapter 552 of the Texas Government Code ("the Texas Public Information Act").
- C. In accordance with Section 2252.907 of the Texas Government Code, Bidder is required to make any information created or exchanged with the State pursuant to this contract, and not otherwise excepted from disclosure under the Texas Public Information Act, available in a format that is accessible by the public at no charge to the state. Bidder will make sure information not excepted from disclosure available in an electronic format that is accessible to the public unless Contractor receives written approval from Owner to provide information in a different format, and such approval becomes a part of this Contract.

1.12 CONTRACTING INFORMATION RESPONSIBILITIES:

In accordance with Section 552.372 of the Texas Government Code, Contractor agrees to (1) preserve all contracting information related to the contract as provided by the records retention requirements applicable to the Owner for the duration of the contract, (2) promptly provide to the Owner any contracting information related to the contract that is in the custody or possession of the Contractor on request of the Owner, and (3) on termination or expiration of the contract, either provide at no cost to the Owner all contracting information related to the contract that is in the custody or possession of the Contractor or preserve the contracting information related to the contract as provided by the records retention requirements applicable to the Owner. Except as provided by Section 552.374(c) of the Texas Government Code, the requirements of Subchapter J, Chapter 552, Government Code, may apply to the contract and the Contractor agrees that the contract can be terminated if the Contractor knowingly or intentionally fails to comply with a requirement of that subchapter.

1.13 RIGHT TO AUDIT/RECORDS RETENTION:

Contractor understands that acceptance of funds under this contract acts as acceptance of the authority of the State Auditor's Office, TPWD or any successor agency, to conduct an audit or investigation in connection with those funds. Contractor further agrees to cooperate fully with the above parties in the conduct of the audit or investigation, including providing all records requested. Pursuant to Section 2262.154 of the Texas Government Code, the state auditor may conduct an audit or investigation of any entity receiving funds from the state directly under any contract or indirectly through a subcontract under the contract. The acceptance of funds by the Contractor or any other entity or person directly under the contract or indirectly through a subcontract under the contract acts as acceptance of the authority of the state auditor, under the direction of the legislative audit committee, to conduct an audit or investigation in connection with those funds. Under the direction of the legislative audit committee, the Contractor or other entity that is the subject of an audit or investigation by the state auditor must provide the state auditor with access to any information the state auditor considers relevant to the investigation or audit. Contractor shall ensure that this paragraph concerning the State's authority to audit funds received indirectly by subcontractors through Contractor and the requirement to cooperate is included in any subcontract it awards. Contractor shall maintain and retain supporting fiscal and any other documents relevant to showing that any payments under this Contract funds were expended in accordance with the laws and regulations of the State of Texas, including but not limited to, requirements of the Comptroller of the State of Texas and the State Auditor. Contractor shall maintain all such documents and other records relating to this Contract and the State's property for a period of seven (7) years after the date of submission of the final invoices or until a resolution of all billing questions, whichever is later. Contractor shall make available at reasonable times and upon reasonable notice, and for reasonable periods, all documents and other information related to the work of this Contract. Contractor and the subcontractors shall provide the State Auditor with any information that the State Auditor deems relevant to any investigation or audit. Contractor must retain all work and other supporting documents pertaining to this Contract, for purposes of inspecting, monitoring, auditing, or evaluating by TPWD and any authorized agency of the State of Texas, including an investigation or audit by the State Auditor. Contractor shall cooperate with any authorized agents of the State of Texas and shall provide them with prompt access to all of such State's work as requested. Contractor's failure to comply with this Section shall constitute a material breach of this Contract and shall authorize TPWD and the State of Texas to immediately assess appropriate damages for such failure.

1.14 IMMIGRATION REFORM:

The Contractor represents and warrants that it shall comply with the requirements of the Immigration Reform and Control Act of 1986 and 1990 regarding employment verification and retention of verification forms for any individuals hired on or after November 6, 1986, who will perform any labor or services under the Contract and the Illegal Immigration Reform and Immigrant Responsibility Act of 1996 (IIRIRA) enacted on September 30, 1996.

1.15 CIVIL RIGHTS:

The Contractor agrees that no person shall, on the ground of race, color, religion, sex, national origin, age, disability, political affiliation, or religious belief, be excluded from the participation in, be denied the benefits of, be subjected to discrimination under, or be denied employment in the administration of, or in connection with, any program or activity funded in whole or in part with funds available under this Contract. The Contract shall comply with Executive Order 11246, "Equal Employment Opportunity," as amended by Executive Order 11375, "Amending Executive Order 11246 relating to Equal Employment Opportunity," and as supplemented by regulations at 41 C.F.R. Part 60, "Office of Federal Contract Compliance Programs, Equal Employment Opportunity Department of Labor."

1.16 FEDERAL, STATE AND LOCAL REQUIREMENTS:

Contractor shall demonstrate on-site compliance with the Federal Tax Reform Act of 1986, Section 1706, amending Section 530 of the Revenue Act of 1978, dealing with issuance of Form W-2's to common law employees. Contractor is responsible for both federal and State unemployment insurance coverage and standard Worker's Compensation insurance coverage. Contractor shall comply with all federal and State tax laws and withholding requirements. The State of Texas shall not be liable to Contractor or its employees for any Unemployment or Worker's Compensation coverage or federal or State withholding requirements. **Contractor shall indemnify the State of Texas and shall pay all costs, penalties or losses resulting from Contractor's omission or breach of this Section.**

1.17 SEVERABILITY CLAUSE:

If any provision of this Contract is construed to be illegal or invalid, such construction will not affect the legality or validity of any of its other provisions. The illegal or invalid provision will be deemed severable and stricken from the contract as if it had never been incorporated herein, but all other provisions will remain in full force and effect.

1.18 SOVEREIGN IMMUNITY:

Nothing in this Contract shall be construed as a waiver of the Owner's or the State's sovereign immunity. This Contract shall not constitute or be construed as a waiver of any of the privileges, rights, defenses, remedies or immunities available to the Owner or the State of Texas. The failure to enforce or any delay in the enforcement of any privileges, rights, defenses, remedies or immunities available to the Owner or the State of Texas under this Contract or under applicable law shall not constitute a waiver of such privileges, rights, defenses, remedies or immunities or be considered as a basis for estoppel. The Owner does not waive any privileges, rights, defenses or immunities available to the Owner by entering into this Contract or by its conduct prior to or subsequent to entering into this Contract.

1.19 DECEPTIVE TRADE PRACTICES; UNFAIR BUSINESS PRACTICES:

Contractor represents and warrants that it has not been the subject of allegations of Deceptive Trade Practices violations under Tex. Bus. & Com Code, Chapter 17 or allegations of any unfair business practice in any administrative hearing or court suit and that Contractor has not been found to be liable for such practices in such proceedings. Contractor certifies that it has no officers who have served as officers of other entities who have been the subject allegations of Deceptive Trade Practices violations or allegations of any unfair business practices in an administrative hearing or court suit, and that such officers have not been found to be liable for such practices in such proceedings.

1.20 FELONY CRIMINAL CONVICTIONS:

Contractor represents that neither Contractor nor any of its employees, agents, or representatives, including any subcontractors and employees, agents, or representative of such subcontractors, have been convicted of a felony criminal offense or that if such a conviction has occurred, Contractor has fully advised the Owner in writing of the facts and circumstances surrounding the convictions.

1.21 ASSIGNMENTS:

The Contractor shall not assign its rights under the Contract or delegate the performance of its duties under the Contract without prior written approval from the Owner. Any attempted assignment in violation of this provision is void and without effect.

1.22 INDEPENDENT CONTRACTOR:

Contractor and Contractor's employees, representatives, agents, subcontractors, suppliers, and third-party service providers shall serve as independent contractors in providing the services under the contract. Neither Contractor nor Owner is an agent of the other and neither may make any commitments on the other party's behalf. Should Contractor subcontract any of the services required in the contract, Contractor expressly understands and acknowledges that in entering into such subcontract(s), Owner is in no manner liable to any subcontractor(s) of Contractor. In no event shall this provision relieve Contractor of the responsibility for ensuring that the services performed under all subcontracts are rendered in compliance with the contract. Contractor shall have no claim against Owner for vacation pay, sick leave, retirement benefits, social security, worker's compensation, health or disability benefits, unemployment insurance benefits, or employee benefits of any kind. The contract shall not create any joint venture, partnership, agency, or employment relationship between Contractor and Owner.

1.23 PATENTS, TRADEMARKS OR COPYRIGHTS:

Contractor agrees to defend and indemnify the Owner and State from claims involving infringement or violation of patents, trademarks, copyrights, trade

secrets, or other proprietary rights, arising out of the Owner's or the State's use of any good or service provided by the Contractor as a result of this solicitation.

1.24 FORCE MAJEURE:

Neither Contractor nor Owner shall be liable to the other for any delay in, or failure of performance, of any requirement included in the contract caused by force majeure. The existence of such causes of delay or failure shall extend the period of performance until after the causes of delay or failure have been removed provided the non-performing party exercises all reasonable due diligence to perform. Force majeure is defined as acts of God, war, fires, explosions, hurricanes, floods, failure of transportation, or other causes that are beyond the reasonable control of either party and that by exercise of due foresight such party could not reasonably have been expected to avoid, and which, by the exercise of all reasonable due diligence, such party is unable to overcome. The Owner may grant relief from performance of contract if the Contractor is prevented from performance by such an act. The burden of proof for the need of such relief shall rest upon the Contractor. To obtain release based on force majeure, the Contractor shall file a written request with the Owner.

1.25 DISASTER RECOVERY PLAN:

Upon request of Owner, Contractor shall provide descriptions of its business continuity and disaster recovery plans.

1.26 U.S. DEPARTMENT OF HOMELAND SECURITY'S E-VERIFY SYSTEM:

Contractor certifies that it utilizes and will continue to utilize, for the term of this Contract, the U.S. Department of Homeland Security's E-Verify system to determine the eligibility of:

- A. All persons employed to perform duties within Texas, during the term of the Contract; and
- B. All persons, including subcontractors, assigned by the Contractor to perform work pursuant to the Contract, within the United States of America.

The Contractor shall provide, upon request of Texas Parks and Wildlife Department, an electronic or hardcopy screenshot of the confirmation or tentative non-confirmation screen containing the E-Verify case verification number for attachment to the Form I-9 for the three most recent hires that match the criteria above, by the Contractor, and Contractor's subcontractors, as proof that this provision is being followed.

If it is determined that Contractor has violated the certifications set forth in this Section, then (1) Contractor shall be in breach of contract, (2) TPWD shall have the option to terminate the contract for cause without prior notice, and (3) in addition to any other rights or remedies available to

TPWD under the contract, Contractor shall be responsible for all costs incurred by TPWD to obtain substitute services to replace the terminated Contract.

1.27 NAME CHANGES AND SALES:

If the Contractor changes its name or is sold to another entity, it must provide written notification to TPWD. The Contractor, in its notice, shall describe the circumstances of the name change or sale, state its new name, provide the new Tax Identification Number, and describe how the change will impact its ability to perform the Contract. If the change entails personnel changes for personnel performing the responsibilities of the Contract for the Contractor, the Contractor shall identify the new personnel and provide resumes to TPWD, if resumes were originally required by the Solicitation. TPWD may request other information about the change and its impact on the Contract and the Contractor shall supply the requested information within five (5) working days of receipt of the request.

TPWD may terminate the Contract due to a sale of or change to the Respondent that materially alters the Respondent's ability to perform under the Contract. The TPWD has the sole discretion to determine if termination is appropriate.

1.28 CYBERSECURITY TRAINING:

Contractor shall ensure that any Contractor employee or subcontractor employee who has access to a state computer system or database shall complete a cybersecurity training program certified under Section 2054.519 of the Texas Government Code. Such training is required to occur during the contract term and the renewal period. Contractor shall provide Owner with verification of the completion of the requisite training.

1.29 DAMAGE TO GOVERNMENT PROPERTY:

In the event of loss, destruction or damage to any Agency or State of Texas property by Respondent or Respondent's employees, agents, subcontractors, and suppliers, Respondent shall be liable to Agency and the State of Texas the full cost of repair, reconstruction or replacement of the lost, destroyed or damaged property. Respondent will reimburse Agency and the State of Texas for such property damage within ten (10) calendar days after Respondent's receipt of Agency's notice of amount due.

PART 2 – EXECUTION

2.01 CONSTRUCTION SITE AND JOB CONDITIONS:

Any temporary connections, appurtenances or extensions for any utilities shall be provided by the Contractor at no cost to the Owner and removed from the premises at the conclusion of the contract. Contractor shall provide cellular telephone service at all times and shall keep Owner informed of telephone number.

A. Utilities:

1. Water:

TPWD water service is available for Contractor to connect to at no charge to the Contractor.

2. Electric:

TPWD Electrical power is available for Contractor to connect to at no charge to the Contractor.

3. Internet / data:

Due to TPWD IT security requirements, Contractor cannot access the internet through the facility's private network. Contractor will be responsible for obtaining internet service for their use during the project.

B. Project Identification: If Contractor desires to erect project signs of any size or type, Contractor must submit a proposed design to and obtain approval from TPWD prior to installation of any project signs. Project sign(s) may not include any references to TPWD or use TPWD's name, logo or other likeness.

C. Fire Protection: The Contractor shall take stringent precautions against fire. Open fires are not allowed unless approved in writing by Owner. Any fires that start or encroach on the Contractor's limits of construction must be immediately reported to the Site Manager.

2.02 SITE OPERATIONS:

During construction of this project the site will remain open to public visitation. It is the responsibility of the Contractor to maintain convenient access and egress to park facilities in a manner to be approved by the Owner. The Contractor shall also be responsible for public safety at the construction site. All temporary fencing, barricades, warning lights, signs, and flagmen shall be provided and maintained by Contractor as needed. The Contractor shall maintain security of construction sites.

2.03 REMOTE VIRTUAL INSPECTIONS

Contractor may be required to facilitate Remote Virtual Inspections (RVI). Contractor will be required to sign TPWD's REMOTE VIRTUAL INSPECTION AGREEMENT, a draft of which is included as an attachment in the solicitation documents.

END OF SECTION

TECHNICAL SPECIFICATIONS
FOR
TEXAS PARKS AND WILDLIFE DEPARTMENT
LJB STATE PARK AND HISTORIC SITE
DANZ CABINS REPAIRS
TPWD NO. CR11387

ISSUED: JUNE 20, 2023

skibala 07/03/2023 4:23:07 PM

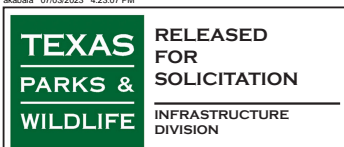

TBPE FIRM # F-761
10350 RICHMOND AVENUE, SUITE 300
HOUSTON, TEXAS 77077
281-496-0066
R313793.01



06/20/2023
Huitt-Zollars Inc.
Firm Registration No. F-761

Table of Contents

TECHNICAL SPECIFICATIONS

DIVISION 01 - GENERAL REQUIREMENTS

015639 - Temporary Tree and Plant Protection

DIVISION 03 - CONCRETE

031000 - Concrete Forming and Accessories

032000 - Concrete Reinforcement

033000 - Cast-In-Place Concrete

DIVISION 04 - MASONRY

044313 - Adhered Stone Masonry Veneer

DIVISION 31 - EARTHWORK

312000 - Earthwork

DIVISION 32 - EXTERIOR IMPROVEMENTS

329200 - Turf and Grasses

END OF TABLE OF CONTENTS

SECTION 01 56 39

TEMPORARY TREE AND PLANT PROTECTION

PART 1 - GENERAL

1.1 RELATED DOCUMENTS

- A. Drawings and general provisions of the Contract, including General and Supplementary Conditions and Division 1 Specification Sections, apply to this Section.

1.2 SUMMARY

- A. This Section includes the protection of trees that interfere with, or are affected by, execution of the Work, whether temporary or new construction.

1.3 SUBMITTALS

- A. Product Data: For each type of product indicated.
- B. Qualification Data: For firms and persons specified in "Quality Assurance" Article to demonstrate their capabilities and experience. Include lists of completed projects with project names and addresses, names and addresses of architects and owners, and other information specified.
- C. Certification: From a qualified Arborist that trees indicated to remain have been protected during construction according to recognized standards and that tree were promptly and properly treated and repaired when damaged.

PART 2 - PRODUCTS

2.1 MATERIALS

- A. Orange Vinyl Fence: Fabric shall be 48" height and constructed of orange plastic mesh containing ultraviolet stabilizers to prevent degradation, with maximum aperture openings of 4.5 square inches, and have minimal tensile strength of 250 pounds per foot in the longitudinal direction and 150 pounds per foot in the vertical direction.

PART 3 - EXECUTION

3.1 PREPARATION

- A. Temporary Fencing: Install temporary fencing located as indicated or outside the drip line of trees to protect remaining vegetation from construction damage.

1. Install 8 foot steel drive-in fence posts (13 gage) approximately 8 feet on center, along drip-line of trees.
 2. Insert steel drive-in posts a minimum of 3 feet into ground, leaving 5 feet above ground.
 3. Secure vinyl fence to posts.
- B. Protect tree root systems from damage due to noxious materials caused by runoff or spillage while mixing, placing, or storing construction materials. Protect root systems from flooding, eroding, or excessive wetting caused by dewatering operations.
- C. Do not store construction materials, debris, or excavated material within the drip line of remaining trees. Do not permit vehicles or foot traffic within the drip line; prevent soil compaction over root systems.
- D. Do not allow fires under or adjacent to remaining trees or other plants.

3.2 EXCAVATION

- A. Install shoring or other protective support systems to minimize sloping or benching of excavations.
- B. Do not excavate within drip line of trees, unless otherwise indicated.
- C. Where excavation for new construction is required within drip line of trees, hand clear and excavate to minimize damage to root systems. Use narrow-tine spading forks and comb soil to expose roots.
1. Relocate roots in backfill areas where possible. If encountering large, main lateral roots, expose roots beyond excavation limits as required to bend and relocate them without breaking. If encountered immediately adjacent to location of new construction and relocation is not practical; cut roots approximately 3 inches back from new construction.
 2. Do not allow exposed roots to dry out before placing permanent backfill. Provide temporary earth cover or pack with peat moss and wrap with burlap. Water and maintain in a moist condition. Temporarily support and protect roots from damage until they are permanently relocated and covered with soil.
- D. Where utility trenches are required within drip line of trees, tunnel under or around roots by drilling, auger boring, pipe jacking, or digging by hand.
1. Root Pruning: Do not cut main lateral roots or taproots; cut only smaller roots that interfere with installation of utilities. Cut roots with sharp pruning instruments; do not break or chop.

3.3 REGRADING

- A. Maintain existing grades within drip line of trees.

- B. Minor Fill: Where existing grade is 6 inches or less below elevation of finish grade, fill with topsoil. Place topsoil in a single uncompacted layer and hand grade to required finish elevations.
- C. Moderate Fill: Where existing grade is more than 6 inches, but less than 12 inches, below elevation of finish grade, place drainage fill, filter fabric, and topsoil on existing grade as follows:
 - 1. Carefully place drainage fill against tree trunk approximately 2 inches above elevation of finish grade and extend not less than 18 inches from tree trunk on all sides. For balance of area within drip-line perimeter, place drainage fill up to 6 inches below elevation of grade.
 - 2. Place filter fabric with edges overlapping 6 inches minimum.
 - 3. Place fill layer of topsoil to finish grade. Do not compact drainage fill or topsoil. Hand grade to required finish elevations.

3.4 TREE REPAIR AND REPLACEMENT

- A. Promptly repair trees damaged by construction operations within 24 hours. Treat damaged trunks, limbs, and roots according to written instructions of a qualified Arborist.
- B. Remove and replace dead and damaged trees that a qualified Arborist determines to be incapable of restoring to a normal growth pattern.
 - 1. Provide new trees of matching caliper size and of a species selected by Engineer when trees more than 4 inches in caliper size, measured 12 inches above grade, are required to be replaced.
- C. Aerate surface soil, compacted during construction, 10 feet beyond drip line and no closer than 36 inches to tree trunk. Drill 2-inch diameter holes a minimum of 12 inches deep at 24 inches o.c. Backfill holes with an equal mix of augered soil and sand.

3.5 DISPOSAL OF WASTE MATERIALS

- A. Burning is not permitted.
- B. Disposal: Remove excess excavated material, displaced trees, and excess chips from TPWD's property.

END OF SECTION 015639

SECTION 031000

CONCRETE FORMING AND ACCESSORIES

PART 1 - GENERAL

1.1 RELATED DOCUMENTS

- A. Drawings and general provisions of the Contract, including General and Supplementary Conditions and Division 01 Specification Sections, apply to this Section.

1.2 SUMMARY

- A. Section Includes:
 - 1. Form-facing material for cast-in-place concrete.
 - 2. Shoring, bracing, and anchoring.
- B. Related Requirements:
 - 1. Section 032000 “Concrete Reinforcing”
 - 2. Section 033000 “Cast-In-Place Concrete”

1.3 DEFINITIONS

- A. Form-Facing Material: Temporary structure or mold for the support of concrete while the concrete is setting and gaining sufficient strength to be self-supporting.
- B. Formwork: The total system of support of freshly placed concrete, including the mold or sheathing that contacts the concrete, as well as supporting members, hardware, and necessary bracing.

1.4 ACTION SUBMITTALS

- A. Product Data: For each of the following:
 - 1. Exposed surface form-facing material.
 - 2. Form-release agent.
- B. Shop Drawings: Formwork for abutment and bridge span.

1.5 INFORMATIONAL SUBMITTALS

- A. Qualification Data: For testing and inspection agency.
- B. Research Reports: For insulating concrete forms indicating compliance with International Code Council Acceptance Criteria AC308.
- C. Field quality-control reports.
- D. Minutes of preinstallation conference.

1.6 QUALITY ASSURANCE

- A. Testing and Inspection Agency Qualifications: An independent agency, acceptable to authorities having jurisdiction, qualified in accordance with ASTM C1077 and ASTM E329 for testing indicated.

1.7 DELIVERY, STORAGE, AND HANDLING

- A. Concrete Forms: Store forms off ground and under cover to protect from moisture, sunlight, dirt, oil, and other contaminants.

PART 2 - PRODUCTS

2.1 PERFORMANCE REQUIREMENTS

- A. Concrete Formwork: Design, engineer, erect, shore, brace, and maintain formwork, shore, and reshore in accordance with ACI 301 (ACI 301M), to support vertical, lateral, static, and dynamic loads, and construction loads that might be applied, until structure can support such loads, so that resulting concrete conforms to the required shapes, lines, and dimensions.
 - 1. Design wood panel forms in accordance with APA's "Concrete Forming Design/Construction Guide."
 - 2. Design formwork to limit deflection of form-facing material for bridge span to L/400 of center-to-center spacing of supports.
- B. Design, engineer, erect, shore, brace, and maintain insulating concrete forms in accordance with ACI 301 (ACI 301M), to support vertical, lateral, static, and dynamic loads, and construction loads that might be applied, until structure can support such loads, so that resulting concrete conforms to the required shapes, lines, and dimensions.
 - 1. Design cross ties to transfer the effects of the following loads to the cast-in-place concrete core:

2.2 FORM-FACING MATERIALS

- A. As-Cast Surface Form-Facing Material:

1. Provide continuous, true, and smooth concrete surfaces.
2. Furnish in largest practicable sizes to minimize number of joints.
3. Acceptable Materials: As required to comply with Surface Finish designations specified in Section 033000 "Cast-In-Place Concrete, and as follows:
 - a. Plywood, metal, or other approved panel materials.
 - b. Exterior-grade plywood panels, suitable for concrete forms, complying with DOC PS 1, and as follows:
 - 1) APA HDO (high-density overlay).
 - 2) APA MDO (medium-density overlay); mill-release agent treated and edge sealed.
 - 3) APA Structural 1 Plyform, B-B or better; mill oiled and edge sealed.
 - 4) APA Plyform Class I, B-B or better; mill oiled and edge sealed.
- B. Concealed Surface Form-Facing Material: Lumber, plywood, metal, plastic, or another approved material.
 1. Provide lumber dressed on at least two edges and one side for tight fit.

PART 3 - EXECUTION

3.1 INSTALLATION OF FORMWORK

- A. Comply with ACI 301 (ACI 301M).
- B. Construct formwork, so concrete members and structures are of size, shape, alignment, elevation, and position indicated, within tolerance limits of ACI 117 (ACI 117M) and to comply with the Surface Finish designations specified in Section 033000 "Cast-In-Place Concrete" for as-cast finishes.
- C. Limit concrete surface irregularities as follows:
 1. Surface Finish-2.0: ACI 117 Class B, 1/4 inch (6 mm).
- D. Construct forms tight enough to prevent loss of concrete mortar.
 1. Exposed Concrete: Symmetrically align joints in forms.
- E. Construct removable forms for easy removal without hammering or prying against concrete surfaces.
 1. Provide crush or wrecking plates where stripping may damage cast-concrete surfaces.
 2. Provide top forms for inclined surfaces steeper than 1.5 horizontal to 1 vertical.
 3. Install keyways, reglets, recesses, and other accessories, for easy removal.
- F. Do not use rust-stained, steel, form-facing material.
- G. Set edge forms, bulkheads, and intermediate screed strips for slabs to achieve required elevations and slopes in finished concrete surfaces.
 1. Provide and secure units to support screed strips

2. Use strike-off templates or compacting-type screeds.
- H. Provide temporary openings for cleanouts and inspection ports where interior area of formwork is inaccessible.
1. Close openings with panels tightly fitted to forms and securely braced to prevent loss of concrete mortar.
 2. Locate temporary openings in forms at inconspicuous locations.
- I. Clean forms and adjacent surfaces to receive concrete. Remove chips, wood, sawdust, dirt, and other debris just before placing concrete.
- J. Retighten forms and bracing before placing concrete, as required, to prevent mortar leaks and maintain proper alignment.

END OF SECTION 031000

SECTION 032000

CONCRETE REINFORCING

PART 1 - GENERAL

1.1 RELATED DOCUMENTS

- A. Drawings and general provisions of the Contract, including General and Supplementary Conditions and Division 01 Specification Sections, apply to this Section.

1.2 SUMMARY

- A. Section Includes:
 - 1. Steel reinforcement bars.

1.3 ACTION SUBMITTALS

- A. Product Data: For the following:
 - 1. Each type of steel reinforcement.
 - 2. Bar supports.

1.4 DELIVERY, STORAGE, AND HANDLING

- A. Steel Reinforcement: Deliver, store, and handle steel reinforcement to prevent bending and damage and to avoid damaging coatings on steel reinforcement.
 - 1. Store reinforcement to avoid contact with earth.

PART 2 - PRODUCTS

2.1 PERFORMANCE REQUIREMENTS

- A. Delegated Design: Engage a qualified professional engineer, as defined in Section 014000 "Quality Requirements," to design structural thermal break insulated connection system, including attachment to building construction.

2.2 STEEL REINFORCEMENT

- A. Reinforcing Bars: ASTM A615/A615M, Grade 60 (Grade 420) deformed.

2.3 REINFORCEMENT ACCESSORIES

- A. Bar Supports: Bolsters, chairs, spacers, and other devices for spacing, supporting, and fastening reinforcing bars and welded-wire reinforcement in place.
 - 1. Manufacture bar supports from steel wire, plastic, or precast concrete in accordance with CRSI's "Manual of Standard Practice," of greater compressive strength than concrete and as follows:
 - a. For concrete surfaces exposed to view, where legs of wire bar supports contact forms, use CRSI Class 1 plastic-protected steel wire, all-plastic bar supports, or CRSI Class 2 stainless steel bar supports.

2.4 FABRICATING REINFORCEMENT

- A. Fabricate steel reinforcement according to CRSI's "Manual of Standard Practice."

PART 3 - EXECUTION

3.1 PREPARATION

- A. Clean reinforcement of loose rust and mill scale, earth, ice, and other foreign materials that reduce bond to concrete.

3.2 INSTALLATION OF STEEL REINFORCEMENT

- A. Comply with CRSI's "Manual of Standard Practice" for placing and supporting reinforcement.
- B. Accurately position, support, and secure reinforcement against displacement.
 - 1. Locate and support reinforcement with bar supports to maintain minimum concrete cover.
 - 2. Do not tack weld crossing reinforcing bars.
- C. Preserve clearance between bars of not less than 1 inch (25 mm), not less than one bar diameter, or not less than 1-1/3 times size of large aggregate, whichever is greater.
- D. Provide concrete coverage in accordance with ACI 318 (ACI 318M).
- E. Set wire ties with ends directed into concrete, not toward exposed concrete surfaces.
- F. Splices: Lap splices if so indicated on Drawings.
 - 1. Bars indicated to be continuous, and all vertical bars shall be lapped not less than 36 bar diameters at splices, or 24 inches (610 mm), whichever is greater.
 - 2. Stagger splices in accordance with ACI 318 (ACI 318M).

3.3 INSTALLATION TOLERANCES

- A. Comply with ACI 117 (ACI 117M).

3.4 FIELD QUALITY CONTROL

- A. Inspections:
 - 1. Steel-reinforcement mechanical splice couplers.
- B. Manufacturer's Inspections: Engage manufacturer of structural thermal break insulated connection system to inspect completed installations prior to placement of concrete, and to provide written report that installation complies with manufacturer's written instructions.

END OF SECTION 032000

SECTION 033000

CAST-IN-PLACE CONCRETE

PART 1 - GENERAL

1.1 RELATED DOCUMENTS

- A. Drawings and general provisions of the Contract, including General and Supplementary Conditions and Division 01 Specification Sections, apply to this Section.

1.2 SUMMARY

A. Section Includes:

- 1. Cast-in-place concrete, including concrete materials, mixture design, placement procedures, and finishes.

B. Related Requirements:

- 1. Section 031000 "Concrete Forming and Accessories" for form-facing materials.
- 2. Section 032000 "Concrete Reinforcing" for steel reinforcing bars.

1.3 DEFINITIONS

- A. Cementitious Materials: Portland cement alone or in combination with one or more of the following: blended hydraulic cement, fly ash, slag cement, other pozzolans, and silica fume; materials subject to compliance with requirements.

- B. Water/Cement Ratio (w/cm): The ratio by weight of water to cementitious materials.

1.4 ACTION SUBMITTALS

A. Product Data: For each of the following.

- 1. Portland cement.
- 2. Blended hydraulic cement.
- 3. Performance-based hydraulic cement
- 4. Aggregates.
- 5. Admixtures:

B. Design Mixtures: For each concrete mixture, include the following:

- 1. Mixture identification.
- 2. Minimum 28-day compressive strength.

3. Durability exposure class.
4. Maximum water/cement ratio.
5. Air content.
6. Nominal maximum aggregate size.
7. Intended placement method.
8. Submit alternate design mixtures when characteristics of materials, Project conditions, weather, test results, or other circumstances warrant adjustments.

1.5 INFORMATIONAL SUBMITTALS

A. Material Certificates: For each of the following, signed by manufacturers:

1. Cementitious materials.
2. Admixtures.
3. Slab treatments.
4. Repair materials.

B. Material Test Reports: For the following, from a qualified testing agency:

1. Portland cement.
2. Slag cement.
3. Blended hydraulic cement.
4. Aggregates.
5. Admixtures:

1.6 DELIVERY, STORAGE, AND HANDLING

A. Comply with ASTM C94/C94M and ACI 301 (ACI 301M).

1.7 FIELD CONDITIONS

A. Cold-Weather Placement: Comply with ACI 301 (ACI 301M) and ACI 306.1 and as follows.

1. Protect concrete work from physical damage or reduced strength that could be caused by frost, freezing actions, or low temperatures.
2. When average high and low temperature is expected to fall below 40 deg F (4.4 deg C) for three successive days, maintain delivered concrete mixture temperature within the temperature range required by ACI 301 (ACI 301M).
3. Do not use frozen materials or materials containing ice or snow.
4. Do not place concrete in contact with surfaces less than 35 deg F (1.7 deg C), other than reinforcing steel.
5. Do not use calcium chloride, salt, or other materials containing antifreeze agents or chemical accelerators unless otherwise specified and approved in mixture designs.

B. Hot-Weather Placement: Comply with ACI 301 (ACI 301M) and ACI 305.1 (ACI 305.1M), and as follows:

1. Maintain concrete temperature at time of discharge to not exceed 95 deg F (35 deg C).
2. Fog-spray forms, steel reinforcement, and subgrade just before placing concrete. Keep subgrade uniformly moist without standing water, soft spots, or dry areas.

1.8 WARRANTY

- A. Manufacturer's Warranty: Manufacturer agrees to furnish replacement sheet vapor retarder/termite barrier material and accessories for sheet vapor retarder/ termite barrier and accessories that do not comply with requirements or that fail to resist penetration by termites within specified warranty period.

1. Warranty Period: 10 years from date of Substantial Completion.

PART 2 - PRODUCTS

2.1 CONCRETE, GENERAL

- A. ACI Publications: Comply with ACI 301 (ACI 301M) unless modified by requirements in the Contract Documents.

2.2 CONCRETE MATERIALS

- A. Source Limitations:

1. Obtain all concrete mixtures from a single ready-mixed concrete manufacturer for entire Project.
2. Obtain each type or class of cementitious material of the same brand from the same manufacturer's plant.
3. Obtain aggregate from single source.
4. Obtain each type of admixture from single source from single manufacturer.

- B. Cementitious Materials:

1. Portland Cement: ASTM C150/C150M, Type I/II gray.

- C. Normal-Weight Aggregates: ASTM C33/C33M Class 3M coarse aggregate or better, graded. Provide aggregates from a single source.

1. Alkali-Silica Reaction: Comply with one of the following:

- a. Expansion Result of Aggregate: Not more than 0.04 percent at one-year when tested in accordance with ASTM C1293.
- b. Expansion Results of Aggregate and Cementitious Materials in Combination: Not more than 0.10 percent at an age of 16 days when tested in accordance with ASTM C1567.
- c. Alkali Content in Concrete: Not more than 4 lb./cu. yd. (2.37 kg/cu. m) for moderately reactive aggregate or 3 lb./cu. yd. (1.78 kg/cu. m) for highly reactive

aggregate, when tested in accordance with ASTM C1293 and categorized in accordance with ASTM C1778, based on alkali content being calculated in accordance with ACI 301 (ACI 301M).

2. Maximum Coarse-Aggregate Size 1 inch (25 mm) nominal.

2.3 CONCRETE MIXTURES, GENERAL

- A. Prepare design mixtures for each type and strength of concrete, proportioned on the basis of laboratory trial mixture or field test data, or both, in accordance with ACI 301 (ACI 301M).
 1. Use a qualified testing agency for preparing and reporting proposed mixture designs, based on laboratory trial mixtures.
- B. Cementitious Materials: Limit percentage, by weight, of cementitious materials other than portland cement in concrete as follows:
 1. Silica Fume: 10 percent by mass.
- C. Admixtures: Use admixtures in accordance with manufacturer's written instructions.
 1. Use water-reducing and -retarding admixture when required by high temperatures, low humidity, or other adverse placement conditions.
 2. Use corrosion-inhibiting admixture in concrete mixtures where indicated.
 3. Use permeability-reducing admixture in concrete mixtures where indicated.
- D. Color Pigment: Add color pigment to concrete mixture in accordance with manufacturer's written instructions and to result in hardened concrete color consistent with approved mockup.

2.4 CONCRETE PERFORMANCE REQUIREMENTS

1. Minimum Compressive Strength: 3,000 psi in 28-days.
2. Slump Limit: 3 inches, plus or minus 1 inch.
3. Air Entrainment Content: 4% max.

2.5 CONCRETE MIXING

- A. Ready-Mixed Concrete: Measure, batch, mix, and deliver concrete in accordance with ASTM C94/C94M, and furnish batch ticket information.
- B. Project-Site Mixing: Measure, batch, and mix concrete materials and concrete in accordance with ASTM C94/C94M. Mix concrete materials in appropriate drum-type batch machine mixer.
 1. For mixer capacity of 1 cu. yd. (0.76 cu. m) or smaller, continue mixing at least 1-1/2 minutes, but not more than five minutes after ingredients are in mixer, before any part of batch is released.
 2. For mixer capacity larger than 1 cu. yd. (0.76 cu. m), increase mixing time by 15 seconds for each additional 1 cu. yd. (0.76 cu. m).

3. Provide batch ticket for each batch discharged and used in the Work, indicating Project identification name and number, date, mixture type, mixture time, quantity, and amount of water added. Record approximate location of final deposit in structure.

PART 3 - EXECUTION

3.1 EXAMINATION

A. Verification of Conditions:

1. Before placing concrete, verify that installation of concrete forms, accessories, and reinforcement, and embedded items is complete and that required inspections have been performed.
2. Do not proceed until unsatisfactory conditions have been corrected.

3.2 PREPARATION

A. Provide reasonable auxiliary services to accommodate field testing and inspections, acceptable to testing agency, including the following:

1. Daily access to the Work.
2. Incidental labor and facilities necessary to facilitate tests and inspections.
3. Secure space for storage, initial curing, and field curing of test samples, including source of water and continuous electrical power at Project site during site curing period for test samples.
4. Security and protection for test samples and for testing and inspection equipment at Project site.

3.3 CONCRETE PLACEMENT

A. Before placing concrete, verify that installation of formwork, reinforcement, embedded items, and vapor retarder is complete and that required inspections are completed.

1. Immediately prior to concrete placement, inspect vapor retarder for damage and deficient installation, and repair defective areas.
2. Provide continuous inspection of vapor retarder during concrete placement and make necessary repairs to damaged areas as Work progresses.

B. Notify Architect and testing and inspection agencies 24 hours prior to commencement of concrete placement.

C. Do not add water to concrete during delivery, at Project site, or during placement unless approved by Architect in writing, but not to exceed the amount indicated on the concrete delivery ticket.

1. Do not add water to concrete after adding high-range water-reducing admixtures to mixture.

- D. Before test sampling and placing concrete, water may be added at Project site, subject to limitations of ACI 301 (ACI 301M), but not to exceed the amount indicated on the concrete delivery ticket.
1. Do not add water to concrete after adding high-range water-reducing admixtures to mixture.
- E. Deposit concrete continuously in one layer or in horizontal layers of such thickness that no new concrete is placed on concrete that has hardened enough to cause seams or planes of weakness.
1. If a section cannot be placed continuously, provide construction joints as indicated.
 2. Deposit concrete to avoid segregation.
 3. Deposit concrete in horizontal layers of depth not to exceed formwork design pressures and in a manner to avoid inclined construction joints.
 4. Consolidate placed concrete with mechanical vibrating equipment in accordance with ACI 301 (ACI 301M).
 - a. Do not use vibrators to transport concrete inside forms.
 - b. Insert and withdraw vibrators vertically at uniformly spaced locations to rapidly penetrate placed layer and at least 6 inches (150 mm) into preceding layer.
 - c. Do not insert vibrators into lower layers of concrete that have begun to lose plasticity.
 - d. At each insertion, limit duration of vibration to time necessary to consolidate concrete, and complete embedment of reinforcement and other embedded items without causing mixture constituents to segregate.
- F. Deposit and consolidate concrete for floors and slabs in a continuous operation, within limits of construction joints, until placement of a panel or section is complete.
1. Do not place concrete floors and slabs in a checkerboard sequence.
 2. Consolidate concrete during placement operations, so concrete is thoroughly worked around reinforcement and other embedded items and into corners.
 3. Maintain reinforcement in position on chairs during concrete placement.
 4. Screed slab surfaces with a straightedge and strike off to correct elevations.
 5. Level concrete, cut high areas, and fill low areas.
 6. Slope surfaces uniformly to drains where required.
 7. Begin initial floating using bull floats or darbies to form a uniform and open-textured surface plane, before excess bleedwater appears on the surface.
 8. Do not further disturb slab surfaces before starting finishing operations.

3.4 FIELD QUALITY CONTROL

- A. Special Inspections: Owner will engage a special inspector to perform field tests and inspections and prepare testing and inspection reports.
1. Testing agency shall be responsible for providing curing container for composite samples on Site and verifying that field-cured composite samples are cured in accordance with ASTM C31/C31M.

2. Testing agency shall immediately report to Architect, Contractor, and concrete manufacturer any failure of Work to comply with Contract Documents.

END OF SECTION 033000

SECTION 044313

REPAIR OF MORTAR IN ADHERED STONE MASONRY VENEER

PART 1 - GENERAL

1.1 RELATED DOCUMENTS

- A. Drawings and general provisions of the Contract, including General and Supplementary Conditions and Division 01 Specification Sections, apply to this Section.

1.2 SUMMARY

- A. Section Includes:
 - 1. Repair of mortar in adhered stone masonry veneer

1.3 PREINSTALLATION MEETINGS

- A. Preinstallation Conference: Conduct conference at Project site.

1.4 ACTION SUBMITTALS

- A. Product Data: For each manufactured product.
- B. Samples for Initial Selection: For mortar involving matching existing mortar color.
- C. Samples for Verification:
 - 1. For each color of mortar required. Label Samples to indicate types and amounts of pigments used.

1.5 INFORMATIONAL SUBMITTALS

- A. Qualification Data: For Installer.

1.6 QUALITY ASSURANCE

- A. Installer Qualifications: A qualified installer who employs experienced stonemasons and stone fitters.

1.7 DELIVERY, STORAGE, AND HANDLING

- A. Store cementitious materials on elevated platforms, under cover, and in a dry location. Do not use cementitious materials that have become damp.
- B. Store aggregates where grading and other required characteristics can be maintained, and contamination avoided.
- C. Deliver preblended, dry mortar mix in moisture-resistant containers designed for use with dispensing silos. Store preblended, dry mortar mix in delivery containers on elevated platforms, under cover, in a dry location, or in covered weatherproof dispensing silos.

1.8 FIELD CONDITIONS

- A. Protection of Stone Masonry: During construction, cover tops of walls, projections, and sills with waterproof sheeting at end of each day's work. Cover partially completed stone masonry when construction is not in progress.
 - 1. Extend cover a minimum of 24 inches down both sides, and hold cover securely in place.
- B. Stain Prevention: Immediately remove mortar and soil to prevent them from staining stone masonry face.
 - 1. Protect base of walls from rain-splashed mud and mortar splatter, using coverings spread on the ground and over the wall surface.
 - 2. Protect sills, ledges, and projections from mortar droppings.
 - 3. Protect surfaces of window and door frames, as well as similar products with painted and integral finishes, from mortar droppings.
 - 4. Turn scaffold boards near the wall on edge at end of each day to prevent rain from splashing mortar and dirt on completed stone masonry.
- C. Cold-Weather Requirements: Do not use frozen materials or materials mixed or coated with ice or frost. Do not build on frozen substrates. Remove and replace stone masonry damaged by frost or freezing conditions. Comply with cold-weather construction requirements contained in TMS 602/ACI 530.1/ASCE 6.
 - 1. Cold-Weather Cleaning: Use liquid cleaning methods only when air temperature is 40 deg F and above and will remain so until masonry has dried, but not less than seven days after completing cleaning.
- D. Hot-Weather Requirements: Comply with hot-weather construction requirements contained in TMS 602/ACI 530.1/ASCE 6.

PART 2 - PRODUCTS

2.1 MORTAR MATERIALS

- A. Portland Cement: ASTM C150/C150M, Type I or Type II, except Type III may be used for cold-weather construction; color pigment for cement may be used as required to produce mortar with color and texture to match existing mortar.
 - 1. Low-Alkali Cement: Not more than 0.60 percent total alkali when tested according to ASTM C114.
- B. Hydrated Lime: ASTM C207, Type S.
- C. Masonry Cement: ASTM C91/C91M.
- D. Mortar Pigments: Natural and synthetic iron oxides and chromium oxides, compounded for use in mortar mixes and complying with ASTM C979/C979M. Use only pigments with a record of satisfactory performance in stone masonry mortar.
- E. Colored Portland Cement-Lime Mix: Packaged blend of portland cement, hydrated lime, and mortar pigments. Mix shall produce color and texture to match existing mortar.
- F. Colored Masonry Cement Mix: Packaged blend of masonry cement and mortar pigments. Mix shall produce color indicated or, if not indicated, as selected from manufacturer's standard colors. Pigments shall not exceed 5 percent of masonry cement by weight.
 - 1. Colored Aggregates: Natural-colored sand or ground marble, granite, or other sound stone; necessary to produce required mortar color and texture to match existing mortar.
- G. Cold-Weather Admixture: Nonchloride, noncorrosive, accelerating admixture complying with ASTM C494/C494M, Type C, and recommended by manufacturer for use in masonry mortar of composition indicated.
- H. Water: Potable.

2.2 MASONRY CLEANERS

- A. Proprietary Acidic Cleaner: Manufacturer's standard-strength cleaner designed for removing mortar and grout stains, efflorescence, and other new construction stains from stone masonry surfaces without discoloring or damaging masonry surfaces; expressly approved for intended use by cleaner manufacturer and stone producer.
 - 1. ProsoSCO, Inc.

2.3 MORTAR MIXES

- A. General: Do not use admixtures, including pigments, air-entraining agents, accelerators, retarders, water-repellent agents, antifreeze compounds, or other admixtures, unless otherwise indicated.

1. Do not use calcium chloride.
 2. Use portland cement-lime, masonry cement, or mortar cement mortar unless otherwise indicated.
 3. Add cold-weather admixture (if used) at same rate for all mortar that will be exposed to view, regardless of weather conditions, to ensure that mortar color is consistent.
 4. Mixing Pointing Mortar: Thoroughly mix cementitious and aggregate materials together before adding water. Then mix again, adding only enough water to produce a damp, unworkable mix that will retain its form when pressed into a ball.
Maintain mortar in this dampened condition for one to two hours. Add remaining water in small portions until mortar reaches required consistency. Use mortar within 30 minutes of final mixing; do not retemper or use partially hardened material.
- B. Preblended, Dry Mortar Mix: Furnish dry mortar ingredients in the form of a preblended mix. Measure quantities by weight to ensure accurate proportions, and thoroughly blend ingredients before delivering to Project site.
- C. Mortar for Stone Masonry: Comply with ASTM C270, Proportion Specification.
1. Mortar for Setting Stone: Type S.
 2. Mortar for Pointing Stone: Type S.
- D. Pigmented Mortar: Use colored cement product or select and proportion pigments with other ingredients to produce color and texture to match existing mortar. Do not add pigments to colored cement products.
1. Pigments shall not exceed 10 percent of portland cement by weight.
 2. Mix to match color and texture of existing mortar.

PART 3 - EXECUTION

3.1 EXAMINATION

- A. Examine cracked mortar surfaces indicated for repair, with Installer present, for compliance with requirements for installation tolerances.
- B. Proceed with installation only after unsatisfactory conditions have been corrected.

3.2 PREPARATION

- A. Clean dirty or stained mortar and adjacent stone surfaces by removing soil, stains, and foreign materials before setting. Clean mortar by thoroughly scrubbing with fiber brushes and then drenching with clear water. Use only mild cleaning compounds that contain no caustic or harsh materials or abrasives.
- B. Rake joints to uniform depths with square bottoms and clean sides.

3.3 POINTING

- A. Prepare stone-joint surfaces for pointing with mortar by removing dust and mortar particles. Where setting mortar was removed to depths greater than surrounding areas, apply pointing mortar in layers not more than 3/8 inch deep until a uniform depth is formed.
- B. Point stone joints by placing and compacting pointing mortar in layers of not more than 3/8 inch deep. Compact each layer thoroughly and allow to it become thumbprint hard before applying next layer.
- C. Tool joints, when pointing mortar is thumbprint hard, with a smooth jointing tool.

3.4 ADJUSTING AND CLEANING

- A. In-Progress Cleaning: Clean stone masonry as work progresses. Remove mortar fins and smears before tooling joints.
- B. Final Cleaning: After mortar is thoroughly set and cured, clean stone masonry as follows:
 - 1. Remove large mortar particles by hand with wooden paddles and nonmetallic scrape hoes or chisels.
 - 2. Test cleaning methods on mockup; leave one-half of panel uncleaned for comparison purposes. Obtain Architect's approval of sample cleaning before cleaning stone masonry.
 - 3. Protect adjacent stone and nonmasonry surfaces from contact with cleaner by covering them with liquid strippable masking agent, polyethylene film, or waterproof masking tape.
 - 4. Wet wall surfaces with water before applying cleaner; remove cleaner promptly by rinsing thoroughly with clear water.
 - 5. Clean stone masonry by bucket and brush hand-cleaning method described in BIA Technical Note No. 20, Revised II, using job-mixed detergent solution.

END OF SECTION 044313

SECTION 312000

EARTHWORK

PART 1 - GENERAL

1.1 SUMMARY

A. Section Includes:

1. Excavation and Fill

1.2 DEFINITIONS

- A. Borrow Soil:** Fill imported from off-site. The source of all imported fill material and the location of all borrow sites for fill material shall be submitted by the Contractor and approved in advance by the TPWD.
- B. Excavation:** Removal of material to lines and dimensions indicated.
1. **Authorized Additional Excavation:** Excavation below subgrade elevations or beyond indicated lines and dimensions as directed by Engineer. Authorized additional excavation and replacement material will be paid for according to Contract provisions for changes in the Work.
 2. **Unauthorized Excavation:** Excavation below subgrade elevations or beyond indicated lines and dimensions without direction by Engineer. Unauthorized excavation, as well as remedial work directed by Engineer, shall be without additional compensation.
- C. Granular Material:** Granular material consist of materials classified as GW, GP, SW, SP, by ASTM D2487 where indicated. The liquid limit of such material must not exceed 35 percent when tested in accordance with ASTM D4318. The plasticity index must not be greater than 10 percent when tested in accordance with ASTM D4318,
- D. Select Fill:** Select fill (whether imported from offsite or is already onsite) should consist of uniform, non-active inorganic lean clays with a liquid limit (LL) equal to or less than 49, plasticity index (PI) between 10 and 20 percent, and more than 50 percent passing a No. 200 sieve. Material intended for use as select fill shall not have clay clods with PI greater than 20, clay clods greater than 2 inches in diameter, or contain sands/silts with PI less than 10. Sand and clay mixtures/blends are unacceptable for use as select fill. Sand/silt with clay clods is unacceptable for use as select fill. Mixing sand into clay or mixing clay into sand/silt is also unacceptable for use as select fill. The testing lab shall reject any material intended for use as select fill that does not meet the PI, sieve, and clay clod requirements above, without exceptions.

1.3 SUBMITTALS

- A. Qualification Data: For qualified testing agency.
- B. Fill Material Locations: The source of all fill material shall be submitted by the Contractor and approved in advance by the TPWD.
- C. Material Test Reports: For each on-site and off-site soil material proposed for fill as follows:
 - 1. Classification according to ASTM D 2487.
 - 2. Laboratory compaction curve according to ASTM D 698.
- D. Pre-excavation Photographs or Videotape: Show existing conditions of adjoining construction and site improvements, including finish surfaces that might be misconstrued as damage caused by earth moving operations. Submit before earth moving begins.

1.4 PROJECT CONDITIONS

- A. Traffic: Minimize interference with adjacent occupied or used facilities during earth moving operations.
 - 1. Do not close or obstruct streets, walks, or other adjacent occupied or used facilities without permission from TPWD.
- B. Do not commence earth moving operations until temporary protection measures are in place.
- C. The following practices are prohibited within protection zones:
 - 1. Storage of construction materials, debris, or excavated material.
 - 2. Parking vehicles or equipment.
 - 3. Foot traffic.
 - 4. Erection of sheds or structures.
 - 5. Impoundment of water.
 - 6. Excavation or other digs unless otherwise indicated.
 - 7. Attachment of signs to or wrapping materials around trees or plants unless otherwise indicated.
- D. Do not direct vehicle or equipment exhaust towards protection zones.
- E. Prohibit heat sources, flames, ignition sources, and smoking within or near protection zones.

PART 2 - PRODUCTS

2.1 SOIL MATERIALS

- A. Provide imported fill only from TPWD-Approved borrow sources.

- B. All references to “Fill” and “Backfill” shall be Select Fill as defined in this specification.
- C. Sand: ASTM C 33; fine aggregate.

PART 3 - EXECUTION

3.1 PREPARATION

- A. Protect structures, utilities, sidewalks, pavements, and other facilities from damage caused by settlement, lateral movement, undermining, washout, and other hazards created by earth moving operations.
- B. Protect and maintain erosion and sedimentation controls during earth moving operations.
- C. Protect subgrades and foundation soils from freezing temperatures and frost. Remove temporary protection before placing subsequent materials.
- D. Contractor shall remove all site vegetation, major roots systems, topsoil, vegetation cover, deleterious materials, concrete slabs, abandoned underground structures/foundation systems and abandoned buried pipelines/conduits in their entirety from beneath the project areas scheduled for new construction.

3.2 CARE AND CONTROL OF WATER

- A. Prevent surface water and ground water from entering excavations, from ponding on prepared subgrades, and from flooding the project site and surrounding area.
- B. Protect subgrades from softening, undermining, washout, and damage by rain or water accumulation.
- C. Grade project area to route surface water runoff away from excavated areas. Do not allow water to accumulate in excavations. Do not use excavated trenches as temporary drainage ditches.

3.3 EXCAVATION

- A. Excavate to subgrade elevations regardless of the character of surface and subsurface conditions encountered to a distance of five (5') feet outside of building perimeter. No changes in the Contract Sum or the Contract Time will be authorized for rock excavation or removal of obstructions.

3.4 STORAGE OF SOIL MATERIALS

- A. Stockpile borrow soil materials and excavated unsatisfactory soil materials without intermixing. Place, grade, and shape stockpiles to drain surface water. Cover to prevent windblown dust.

1. Stockpile soil materials away from edge of excavations. Do not store within drip line of remaining trees. All stockpiled spoils shall be protected by silt fencing.

3.5 SELECT FILL

- A. Place and compact select fill in excavations promptly, but not before completing the following:
 1. Construction below finish grade including, where applicable, subdrainage, dampproofing, waterproofing, and perimeter insulation.
 2. Removing concrete formwork.
 3. Removing trash and debris.
- B. Do not place select fill on subgrades containing mud, frost, snow, or ice.

3.6 SOIL MOISTURE CONTROL

- A. Uniformly moisten or aerate subgrade and each subsequent fill or backfill soil layer before compaction to within 2 percent of optimum moisture content.
 1. Do not place fill soil material on surfaces that are muddy, frozen, or contain frost or ice.
 2. Remove and replace, or scarify and air dry, otherwise satisfactory soil material that exceeds optimum moisture content by 2 percent and is too wet to compact to specified dry unit weight.

3.7 COMPACTION OF SELECT FILL

- A. Place select fill soil materials in horizontal loose layers not more than 4 inches in loose depth for material compacted by hand-operated tampers.
- B. Place select fill soil materials evenly on all sides of structures to required elevations, and uniformly along the full length of each structure.
- C. Compact soil materials to not less than the following percentages of Standard Proctor Maximum Dry Density according to ASTM D 698:
 1. Scarify and recompact top 4 inches below subgrade and compact each layer of backfill or fill soil material at 85 percent Standard Proctor Maximum Dry Density.

3.8 GRADING

- A. General: Uniformly grade areas to a smooth surface, free of irregular surface changes. Comply with compaction requirements and grade to cross sections, lines, and elevations indicated.
 1. Provide a smooth transition between adjacent existing grades and new grades.

2. Cut out soft spots, fill low spots, and trim high spots to comply with required surface tolerances.

- B. Site Rough Grading: Slope grades to direct water away from structures and to prevent ponding.

3.9 PROTECTION

- A. Protecting Graded Areas: Protect newly graded areas from traffic, freezing, and erosion. Keep free of trash and debris.

- B. Repair and reestablish grades to specified tolerances where completed or partially completed surfaces become eroded, rutted, settled, or where they lose compaction due to subsequent construction operations or weather conditions.

1. Scarify or remove and replace soil material to depth as directed by Engineer; reshape and recompact.

- C. Where settling occurs before Project correction period elapses, remove finished surfacing, backfill with additional soil material, compact, and reconstruct surfacing.

1. Restore appearance, quality, and condition of finished surfacing to match adjacent work, and eliminate evidence of restoration to greatest extent possible.

3.10 DISPOSAL OF SURPLUS AND WASTE MATERIALS

- A. Remove surplus satisfactory soil and waste materials, including unsatisfactory soil, trash, and debris, and legally dispose of them off TPWD's property.

END OF SECTION 312000

SECTION 329200

TURF AND GRASSES

PART 1 - GENERAL

1.1 RELATED DOCUMENTS

- A. Drawings and general provisions of the Contract, including General and Supplementary Conditions and Division 01 Specification Sections, apply to this Section.

1.2 SUMMARY

- A. Section Includes:
 - 1. Native Grass Seeding.
 - 2. Buffalograss Sod.
 - 3. Top Soil.

1.3 DEFINITIONS

- A. Finish Grade: Elevation of finished surface of planting soil.
- B. Top Soil: Existing, on-site soil; imported soil; or manufactured soil that has been modified with soil amendments and perhaps fertilizers to produce a soil mixture best for plant growth.
- C. Subgrade: The surface or elevation of subsoil remaining after excavation is complete, or the top surface of a fill or backfill before planting soil is placed.

1.4 INFORMATIONAL SUBMITTALS

- A. Qualification Data: For landscape Installer.
- B. Certification of Grass Seed: From seed vendor for each grass-seed monostand or mixture, stating the botanical and common name, percentage by weight of each species and variety, and percentage of purity, germination, and weed seed. Include the year of production and date of packaging.
- C. Product Certificates: For fertilizers, from manufacturer.

1.5 QUALITY ASSURANCE

- A. Installer Qualifications: A qualified landscape installer whose work has resulted in successful and meadow establishment.

1. Professional Membership: Installer shall be a member in good standing of either the National Association of Landscape Professionals or AmericanHort.
2. Experience: Three years' experience in native grass & sod installation.
3. Installer's Field Supervision: Require Installer to maintain an experienced full-time supervisor on Project site when work is in progress.
4. Personnel Certifications: Installer's field supervisor shall have certification in the following categories from the National Association of Landscape Professionals:
 - a. Landscape Industry Certified Technician - Exterior.

1.6 DELIVERY, STORAGE, AND HANDLING

- A. Seed and Other Packaged Materials: Deliver packaged materials in original, unopened containers showing weight, certified analysis, name and address of manufacturer, and indication of compliance with state and Federal laws, as applicable.
- B. Bulk Materials:
 1. Do not dump or store bulk materials near structures, utilities, walkways and pavements, or on existing turf areas or plants.
 2. Provide erosion-control measures to prevent erosion or displacement of bulk materials; discharge of soil-bearing water runoff; and airborne dust reaching adjacent properties, water conveyance systems, or walkways.
 3. Accompany each delivery of bulk materials with appropriate certificates.

1.7 FIELD CONDITIONS

- A. Planting Restrictions: Coordinate planting periods with initial maintenance periods to provide required maintenance from date of planting until the end of the warranty period. To reduce site erosion, contractor shall begin seeding operations as soon as conditions will allow after all other construction operations are completed in an area.
- B. Weather Limitations: Proceed with planting only when existing and forecasted weather conditions permit planting to be performed when beneficial and optimum results may be obtained. Apply products during favorable weather conditions according to manufacturer's written instructions.

PART 2 - PRODUCTS

2.1 SEED

- A. Grass Seed: Fresh, clean, dry, new-crop seed complying with AOSA's "Rules for Testing Seeds" for purity and germination tolerances.
- B. Grass-Seed Mix: Native Grasses as approved by TWPD.

2.2 SOD

- A. Provide live, growing Buffalograss Sod containing no more than 5% noxious weeds.

PART 3 - EXECUTION

3.1 EXAMINATION

- A. Examine areas to be planted for compliance with requirements and other conditions affecting installation and performance of the Work.
 - 1. Verify that no foreign or deleterious material or liquid such as paint, paint washout, concrete slurry, concrete layers or chunks, cement, plaster, oils, gasoline, diesel fuel, paint thinner, turpentine, tar, roofing compound, or acid has been deposited in soil within a planting area.
 - 2. Suspend planting operations during periods of excessive soil moisture until the moisture content reaches acceptable levels to attain the required results.
 - 3. Uniformly moisten excessively dry soil that is not workable or which is dusty.
- B. Proceed with installation only after unsatisfactory conditions have been corrected.
- C. If contamination by foreign or deleterious material or liquid is present in soil within a planting area, remove the soil and contamination as directed by Landscape Architect and replace with new planting soil.

3.2 PREPARATION

- A. Protect structures; utilities; sidewalks; pavements; and other facilities, trees, shrubs, and plantings from damage caused by planting operations.
 - 1. Protect grade stakes set by others until directed to remove them.

3.3 SOD AND NATIVE GRASS AREA PREPARATION

- A. Placing Planting Soil: Place four (4) inches of topsoil prior to planting. Areas where additional topsoil is needed for a seedbed or areas that received fill as part of the grading and erosion repair operations should be gently rolled prior to planting.
- B. Moistened prepared area before planting if surface is dry. Water thoroughly and allow surface to dry before planting. Do not create muddy soil.

3.4 SEEDING

- A. Sow seed by hand broadcasting and rake into the soil to ¼” depth. Do not broadcast or drop seed when wind velocity exceeds 5 mph (8 km/h).

1. Evenly distribute seed by sowing equal quantities in two directions at right angles to each other.
2. Do not use wet seed or seed that is moldy or otherwise damaged.

3.5 GRASS MAINTENANCE

- A. Maintain and establish native grasses and sod by watering, weeding, mowing, trimming, replanting, and performing other operations as required to establish a healthy, viable lawn.

3.6 CLEANUP AND PROTECTION

- A. Remove surplus soil and waste material, including excess subsoil, unsuitable soil, trash, and debris, and legally dispose of them off TPWD's property.
- B. Erect temporary fencing or barricades and warning signs as required to protect newly planted areas from traffic. Maintain fencing and barricades throughout initial maintenance period and remove after plantings are established.

END OF SECTION 329200

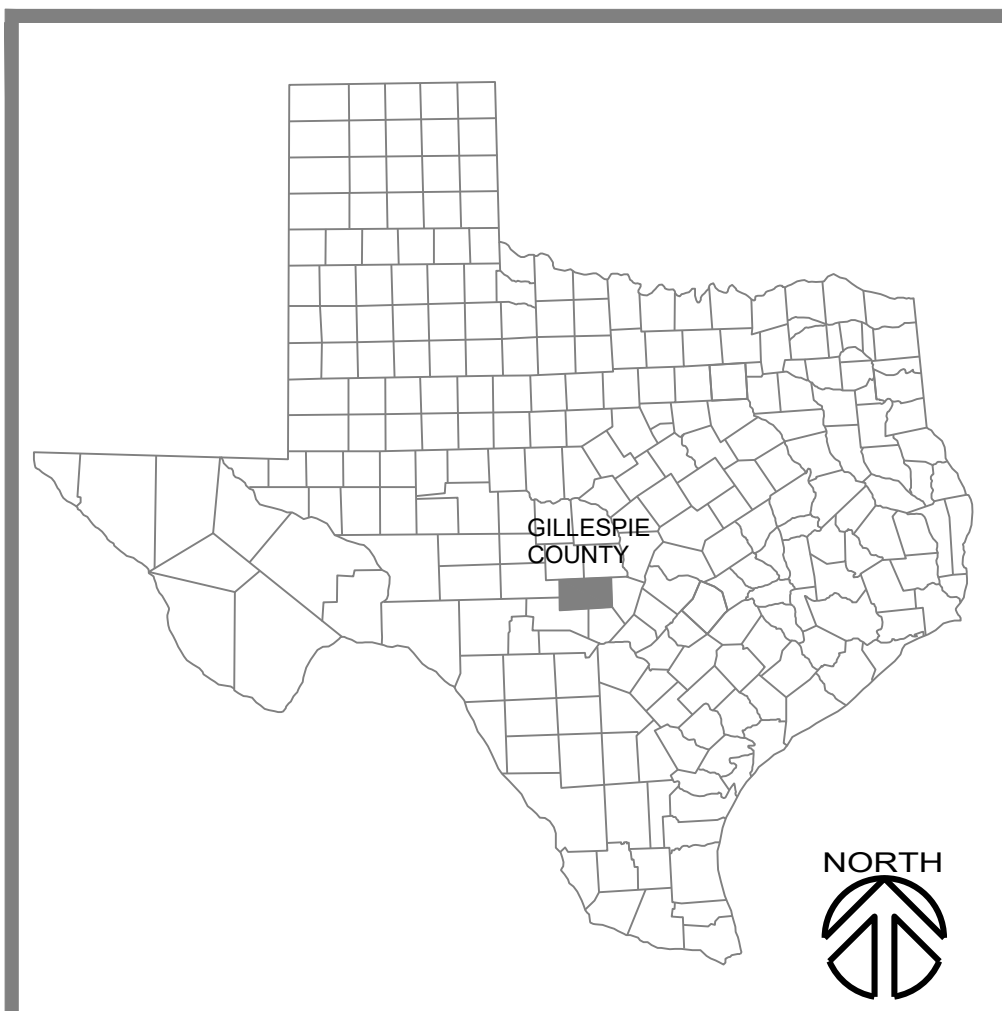

COUNTY LOCATION MAP

NOT TO SCALE

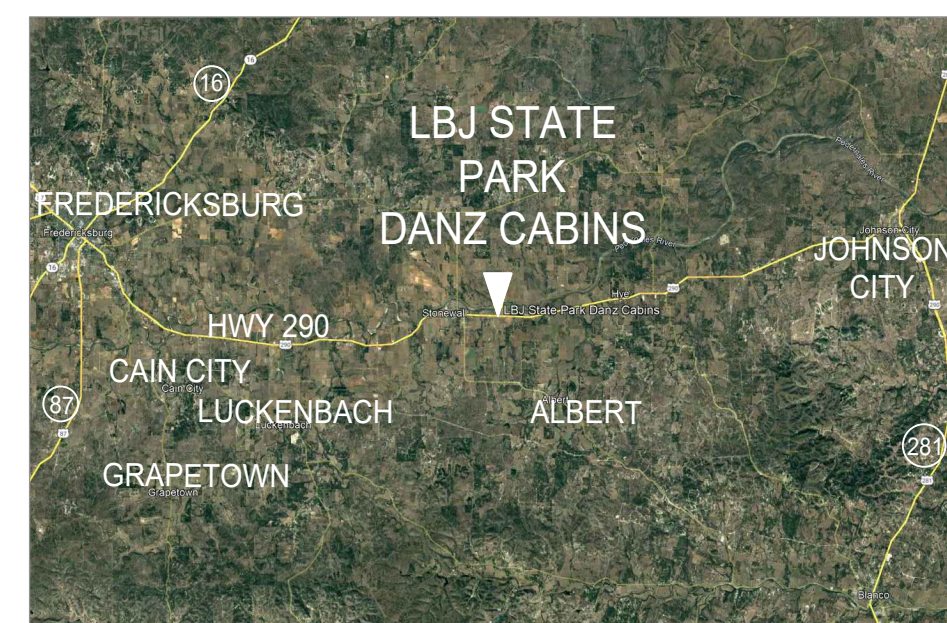

VICINITY MAP

NOT TO SCALE

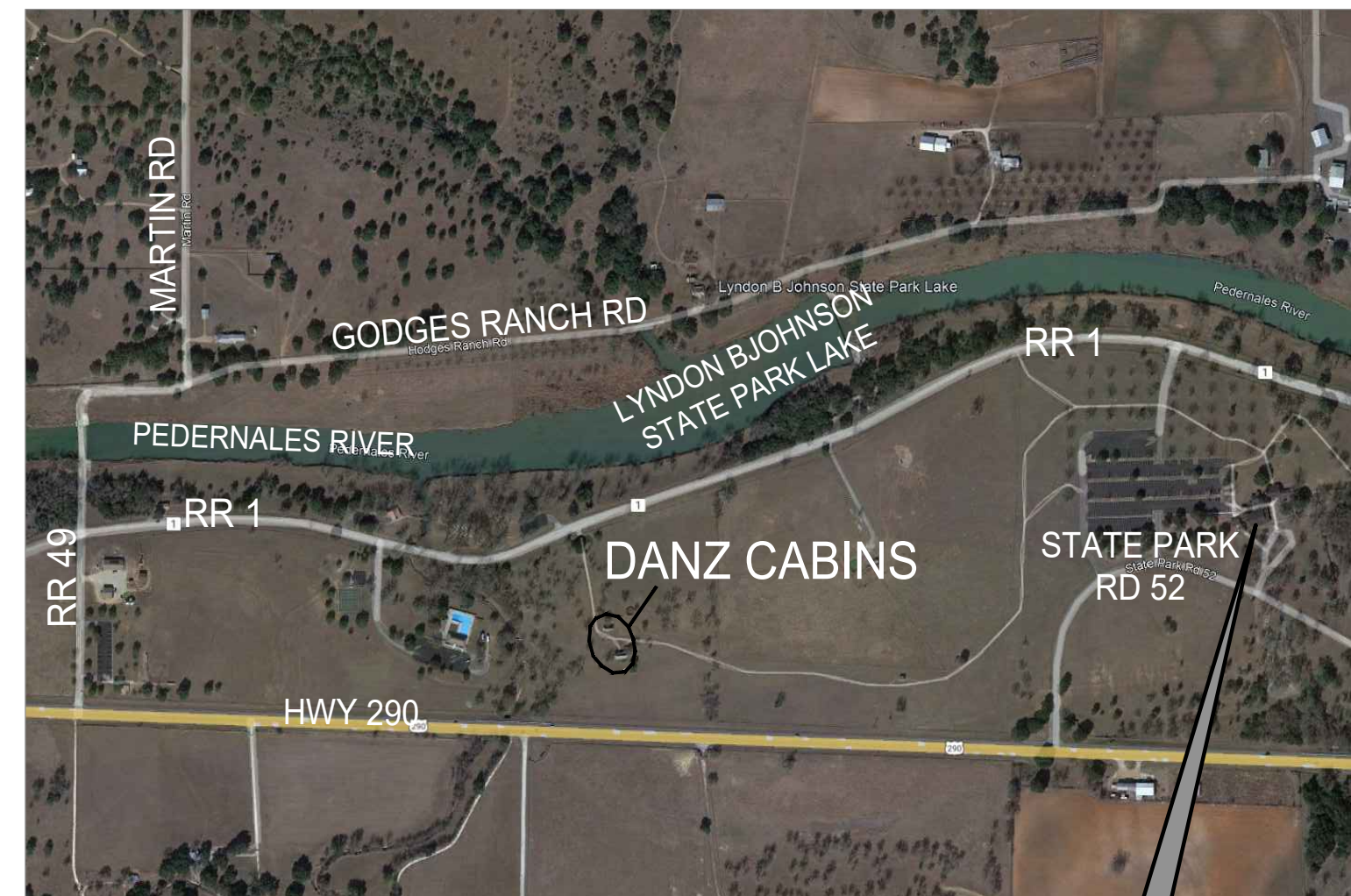

SITE LOCATION MAP

NOT TO SCALE



SITE ADDRESS:
LBJ STATE PARK
199 PARK ROAD #52
STONEWALL, TX 78671

LBJ STATE PARK HQ
 199 PARK ROAD #52
 STONEWALL, TX 78671

ADOPTED CODES

- I. INTERNATIONAL CODE COUNCIL ADOPTIONS*
 - i. BUILDING CODE INTERNATIONAL BUILDING CODE 2021
 - ii. STRUCTURAL CODE INTERNATIONAL BUILDING CODE 2021
 - iii. PLUMBING CODE INTERNATIONAL PLUMBING CODE 2021
 - iv. MECHANICAL CODE INTERNATIONAL MECHANICAL CODE 2021
 - v. GAS CODE INTERNATIONAL FUEL GAS CODE 2021
 - vi. RESIDENTIAL CODE INTERNATIONAL RESIDENTIAL CODE 2021
 - vii. EXISTING BUILDINGS INTERNATIONAL EXISTING BUILDING CODE 2021

*International Fire Code omitted in lieu of TPWD's implementation of National Fire Protection Association codes.

II. NATIONAL FIRE PROTECTION ASSOCIATION

- i. ELECTRICAL CODE NATIONAL ELECTRIC CODE NFPA-70 2020
- ii. FIRE CODE NFPA-1 2015
- iii. LIFE SAFETY CODE NFPA-101 2015

III. ENERGY CONSERVATION

- i. ENERGY * INTERNATIONAL ENERGY CONSERVATION CODE 2021

* Energy Standards for State-Founded Buildings, ASHRAE/IESNA Standard 90.1 (2013) omitted in lieu of INTERNATIONAL ENERGY CONSERVATION CODE 2021

IV. WATER

- i. WATER SUPPLY TEXAS ADMIN CODE - TITLE 30 PART 1 CHAPTER 290
- ii. LANDSCAPE IRRIGATION TEXAS ADMIN CODE - TITLE 30 PART 1 CHAPTER 344
- iii. ON-SITE SEWAGE TEXAS ADMIN CODE - TITLE 30 PART 1 CHAPTER 217

V. ACCESSIBILITY CODES

- i. US DEPT. OF JUSTICE, 2010 ADA STANDARDS FOR ACCESSIBLE DESIGN
- ii. ARCHITECTURAL BARRIERS ACT ACCESSIBILITY GUIDELINES; OUTDOOR DEVELOPED AREAS 2015
- iii. 2012 TEXAS ACCESSIBILITY STANDARDS, ELIMINATION OF ARCHITECTURAL BARRIERS, TEXAS GOVERNMENT CODE; CHAPTER 469

VI. PLAYGROUND SAFETY CODE

- i. ASTM F1487-17. STANDARD CONSUMER SAFETY PERFORMANCE SPECIFICATIONS FOR PLAYGROUND EQUIPMENT FOR PUBLIC USE
- ii. ASTM F2223-15. STANDARD GUIDE FOR ASTM STANDARDS ON PLAYGROUND SURFACING

PROJECT
LBJ STATE PARK

DANZ CABINS REPAIRS

TPWD PROJECT NO: CR11387
 HZ PROJECT NO: R313793.01 DATE: JUNE 2023

INDEX OF DRAWINGS

SHEET NO.	DESCRIPTION
NO.	DWG NO. DRAWING TITLE
GENERAL	
1	G-1 COVER SHEET
2	G-2 GENERAL INFORMATION
CIVIL	
3	C-1 EXISTING SITE
4	C-2 SITE PLAN
5	C-3 NORTH CABIN GRADING & DRAINAGE PLAN
6	C-4 TREE PROTECTION DETAILS
ARCHITECTURAL	
7	A-1 NORTH CABIN PLAN & ELEVATIONS
8	A-2 SOUTH CABIN PLAN & ELEVATIONS
STRUCTURAL	
9	S-1 STRUCTURAL PLANS & DETAILS
10	S-2 STRUCTURAL PHOTOS & NOTES

TPWD REVIEW TEAM

PROJECT MANAGER
 JAMES HESS
 State Park -Region 3
 Project Manager/ Regional Maintenance
 Specialist
 Office (512) 308-1475 x 6612
 james.hess@tpwd.texas.gov

DESIGN TEAM

CIVIL
 Robert Powell, PE,
 Huitt-Zollars, Inc.
 281-496-0066
 bpowell@Huitt-Zollars.com
 TBPE Firm Registration No. F-761

STRUCTURAL
 Brion Echols, PE,
 Huitt-Zollars, Inc.
 281-496-0066
 bechols@Huitt-Zollars.com
 TBPE Firm Registration No. F-761

SCOPE OF WORK

HISTORIC CABINS REPAIRS

RELEASED FOR SOLICITATION



TEXAS PARKS AND WILDLIFE
INFRASTRUCTURE DIVISION

4200 SMITH SCHOOL RD, AUSTIN, TX 78444

100% SUBMITTAL

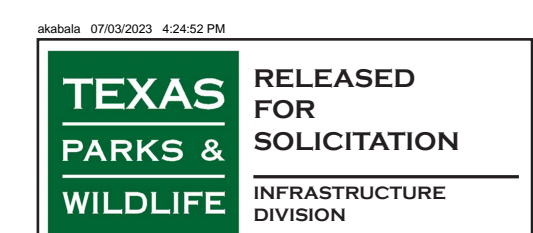

SHEET NUMBER
 G-1
 SHEET 1 OF 10

P:\0313793101 - TPWD P&W 517232 HISTORICAL PROJECTS\10 CAD & BIA\10.1 AutoCAD\20210709 GENERAL.dwg

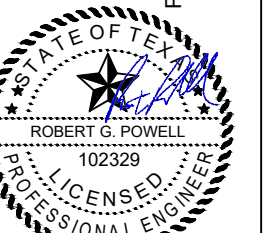

LBJ STATE PARK
DANZ CABINS REPAIRS
TPWD PROJECT # CR11387

DATE: 06/20/2023
DESIGNED BY: RGP
DRAWN BY: RGP
REVIEWED BY: GRW
REVISED:
REVISED:

SHEET TITLE
EXISTING
SITE

SHEET NUMBER
C-1
SHEET OF 10

100% CONSTRUCTION DOCUMENTS

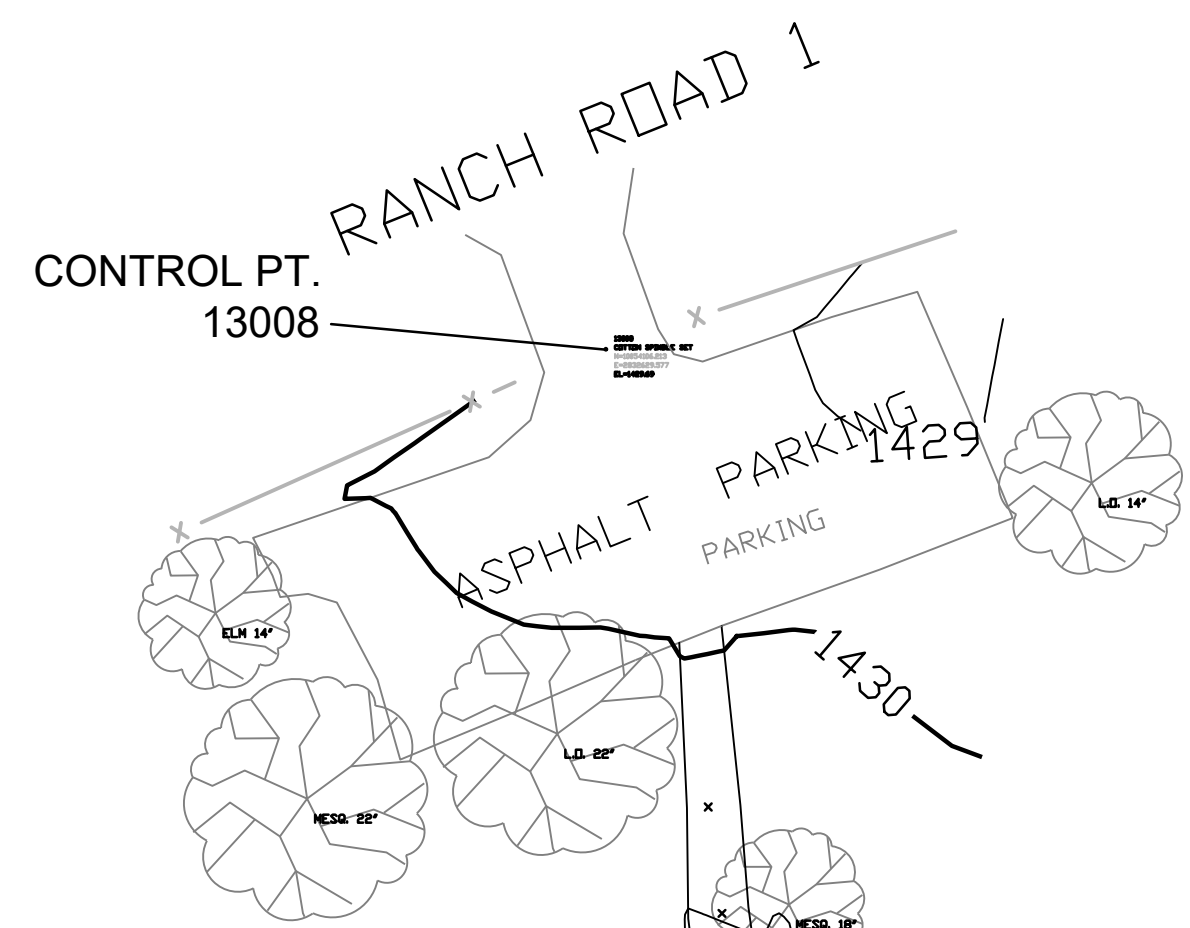

DANZ CABINS SURVEY
L.B.J. STATE PARK 9-19-2008 NAD83

Node ID	Northing	Easting	Elevation	Description
13008	10054106.21	2832629.58	1429.69	COTTON SPINDLE SET
13009	10053658.27	2832727.04	1436.33	1/2" REBAR TPWD CAP
13010	10053653.87	2832853.48	1439.40	1/2" REBAR TPWD CAP

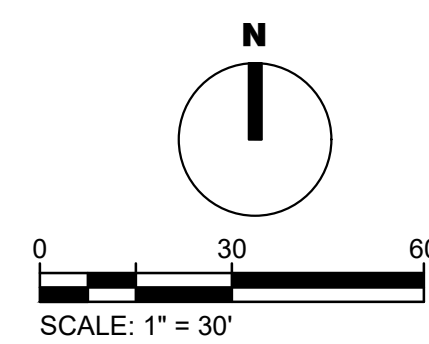
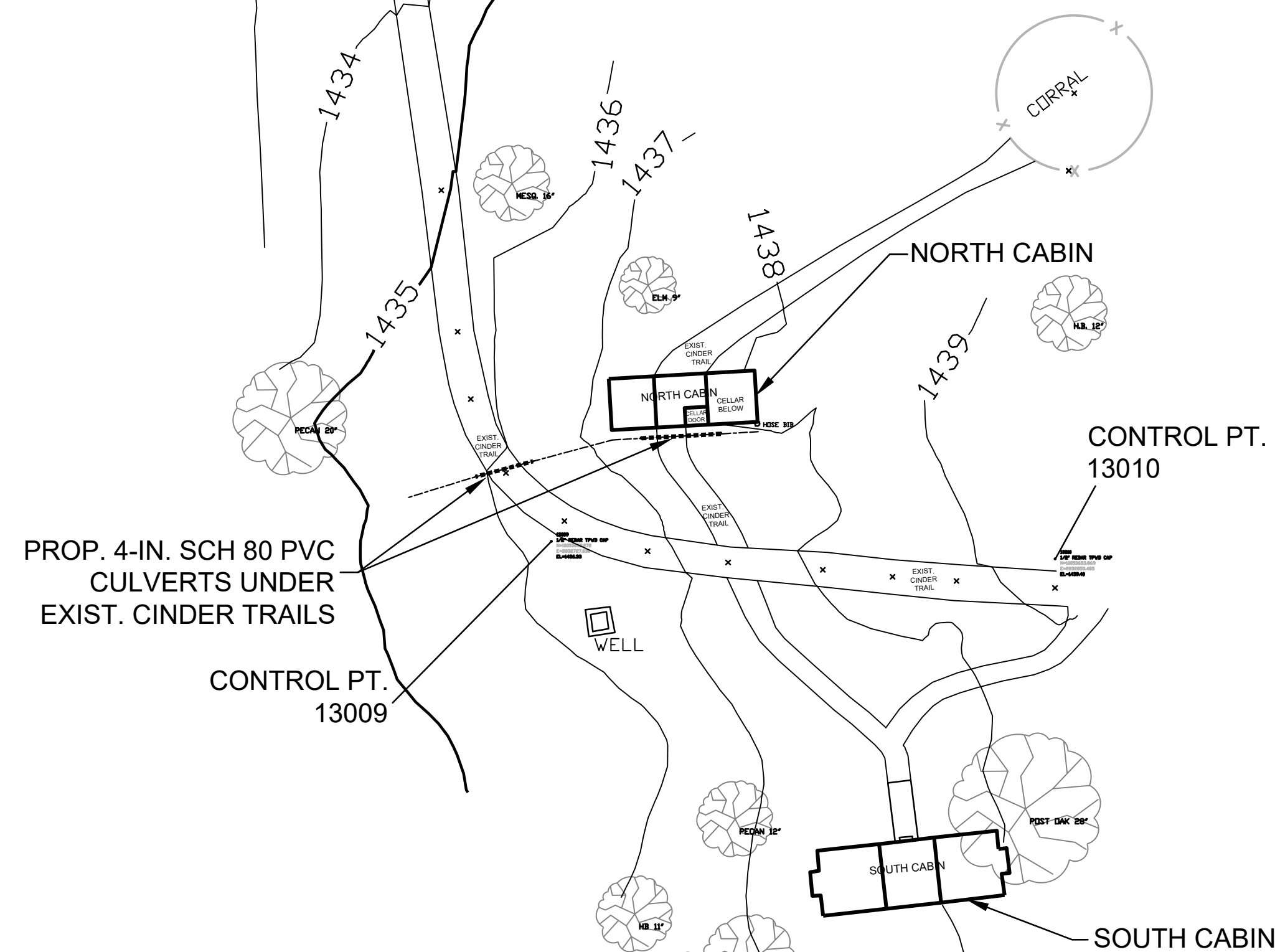

NOTE: THIS DAWING AND OTHER
CIVIL SHEETS ARE BACED ON
OWNER PROVIDED 2008 SURVEY

PROP. 4-IN. SCH 80 PVC
CULVERTS UNDER
EXIST. CINDER TRAILS

NORTH CABIN KEYED NOTES

- 1 CONTRACTOR TO PROVIDE PROTECTION FOR HISTORIC BUILDING AND ADJACENT TREES/VEGETATION FROM POTENTIAL CONSTRUCTION DAMAGE.
- 2 EXISTING STONE WALL TO REMAIN AS IS. NOT PART OF SCOPE OF WORK. PROVIDE WALL PROTECTION SHORING AS NEEDED TO PREVENT ANY DISTURBANCE TO WALL DURING CONSTRUCTION PROCESS.
- 3 CONTRACTOR TO PROVIDE TEMPORARY SUPPORTS FOR EXISTING BUILDING WALLS PRIOR TO EXCAVATING FOR INSTALLATION OF CONCRETE BARRIER WALL AND FOOTER, HELICAL PILES, AND HELICAL PILE UNDER-FOOTING BRACKETS.
- 4 EXIST. HOSE BIB; CONTRACTOR TO CHECK AND REPAIR ANY LEAKS PRIOR TO EXCAVATION. INSTALL TEMPORARY OFFSET AND SHUTOFF VALVE SO LINE IS NOT IN CONFLICT WITH PROPOSED WORK. RESTORE HOSE BIB TO ORIGINAL OR ADJACENT LOCATION AFTER ALL OTHER EXCAVATION, STRUCTURAL WORK, BACKFILL, AND GRADING WORK ARE COMPLETE. COORDINATE FINAL HOSE BIB LOCATION WITH OWNER.
- 5 CONTRACTOR TO VERIFY HISTORIC PERIMETER FOUNDATION CONDITIONS PRIOR TO COMMENCING WITH CONSTRUCTION. NOTIFY ARCHITECT PRIOR TO PROCEEDING WITH CONSTRUCTION IF CONDITIONS VARY FROM ARCHITECTURAL / ENGINEERING DOCUMENTS.
- 6 EXCAVATE OUTSIDE OF SOUTH CELLAR WALL TO REMOVE LATERAL LOAD. SEE S-1, DETAIL 5.
- 7 INSTALL HELICAL PILES AND UNDER FOOTER BRACKETS TO CURRENT BOTTOM OF FOOTER ELEVATION TO PREVENT FURTHER SETTLEMENT.
***** DO NOT LIFT THE STRUCTURE. ***** SEE DETAIL 4/S-1
EXCAVATE MINIMUM AMOUNT NEEDED FOR PROPER INSTALLATION OF HELICAL PILES AND UNDER FOOTER BRACKETS. SEE DETAIL 2 ON S-1 FOR LOCATIONS.
- 8 AFTER HELICAL PILES ARE INSTALLED AT LOCATIONS SHOWN, INSTALL PROP. CONCRETE BARRIER WALL AND FOOTER, WITH BOND BREAKER MATERIAL BETWEEN EXISTING STRUCTURE AND NEW CONCRETE. SEE DETAIL 5/S-1
- 9 BACKFILL IN ACCORDANCE WITH STRUCTURAL NOTES ON DRAWING S-1.
- 10 SLOPE FINAL GRADING AWAY FROM BUILDING TO ENSURE POSITIVE DRAINAGE; COORD. W/ CINDER TRAIL RESTORED TO PRE-CONSTRUCTION ELEVATIONS.
- 11 INSTALL BUFFALO GRASS SOD AROUND CABIN AT DISTURBED AREAS. OMIT SOD AT CINDER TRAILS.
- 12 USE APPROVED NATIVE GRASS SEED MIX TO RE-ESTABLISH GRASS IN ALL DISTURBED AREAS BEYOND LIMIT OF BUFFALO GRASS SOD.
- 13 RESTORE DISTURBED CINDER TRAILS TO PRE-CONSTRUCTION CONDITIONS AFTER COMPLETION AND ACCEPTANCE OF ALL OTHER WORK.
- 14 NORTH CABIN CRACK REPAIRS: PERFORM CRACK REPAIRS AS SHOWN ON A-1. PERFORM REPAIRS AFTER COMPLETION OF STRUCTURAL STABILIZATION WORK (SEE S-1)

SOUTH CABIN KEYED NOTES

- 1 CONTRACTOR TO PROVIDE PROTECTION FOR HISTORIC BUILDING AND ADJACENT TREES/VEGETATION FROM POTENTIAL CONSTRUCTION DAMAGE.
- 2 PROVIDE WALL PROTECTION SHORING TO PREVENT ANY DISTURBANCE TO WALLS DURING CONSTRUCTION PROCESS.
- 3 EXCAVATE MINIMUM AMOUNT NEEDED FOR PROPER INSTALLATION OF HELICAL PILES AND UNDER FOOTER BRACKETS. SEE DETAIL 1 ON S-1 FOR LOCATIONS.
- 4 CONTRACTOR TO VERIFY HISTORIC PERIMETER FOUNDATION CONDITIONS PRIOR TO COMMENCING WITH CONSTRUCTION. NOTIFY ARCHITECT PRIOR TO PROCEEDING WITH CONSTRUCTION IF CONDITIONS VARY FROM CONSTRUCTION DOCUMENTS.
- 5 INSTALL HELICAL PILES AND UNDER FOOTER BRACKETS TO CURRENT BOTTOM OF FOOTER ELEVATION TO PREVENT FURTHER SETTLEMENT.
***** DO NOT LIFT THE STRUCTURE. ***** SEE DETAIL 3/S-1
- 6 BACKFILL IN ACCORDANCE WITH STRUCTURAL NOTES ON DRAWING S-1.
- 7 SOUTH CABIN CRACK REPAIRS: PERFORM REPAIRS BOTH INSIDE AND OUTSIDE THE CABIN AT LOCATIONS NOTED (SEE A-2). PERFORM MORTAR/CRACK REPAIRS AFTER COMPLETION OF STRUCTURAL STABILIZATION WORK (SEE S-1).
- 8 USE APPROVED NATIVE GRASS SEED MIX TO RE-ESTABLISH GRASS IN ALL DISTURBED AREAS BEYOND LIMIT OF BUFFALO GRASS SOD.
- 9 RESTORE DISTURBED CINDER TRAILS TO PRE-CONSTRUCTION CONDITIONS AFTER COMPLETION AND ACCEPTANCE OF ALL OTHER WORK.

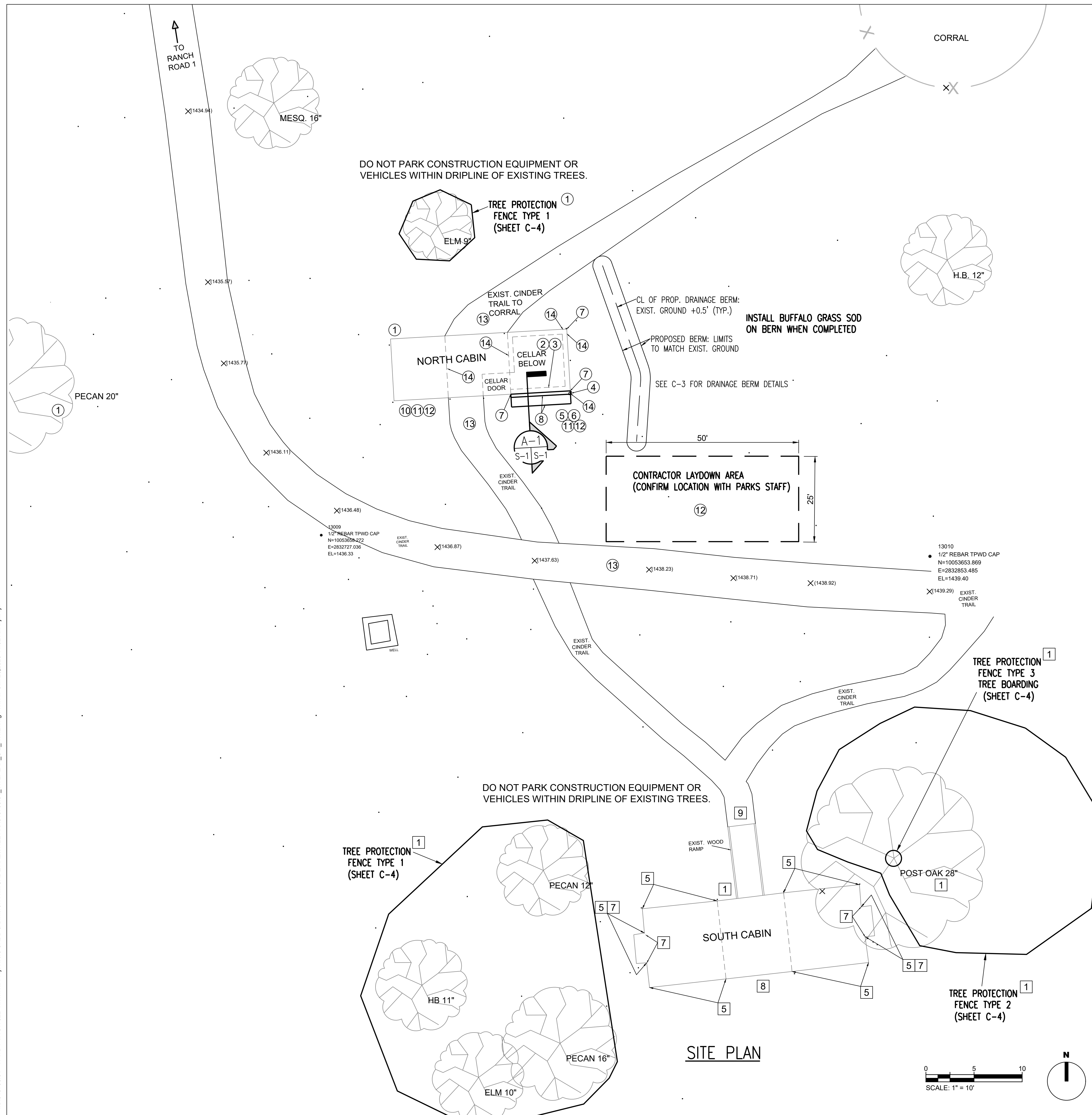

SITE PLAN

I:\R319793.01 - TPWD PSA 817522 - Historical Projects\10 CAD & BIM\10.1 AutoCAD\DWG\SHEET\B\19793.01_SITEPLAN_C-2_New2.dwg Plotted: Jun 20 2023 11:02 AM ljlubaja

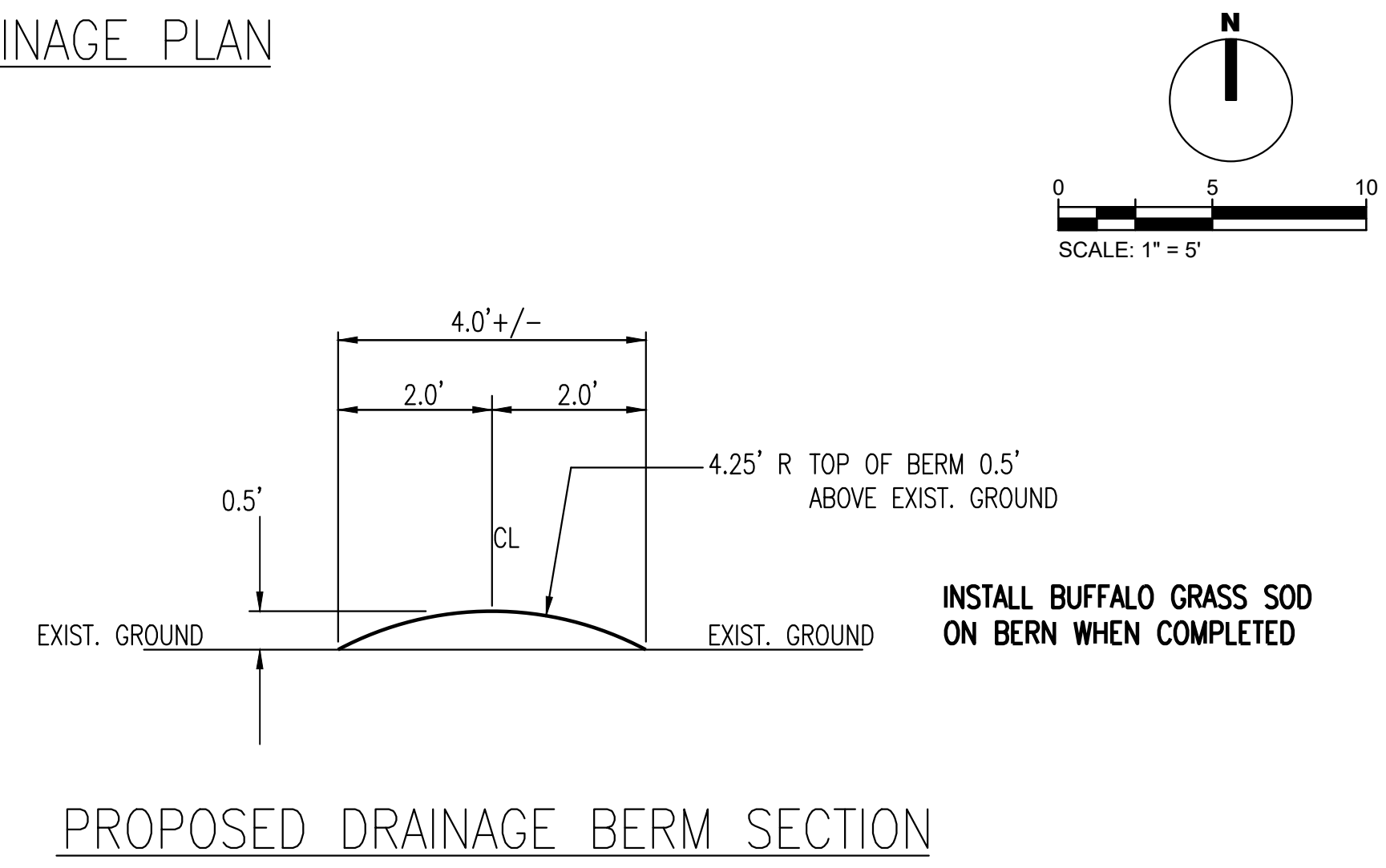
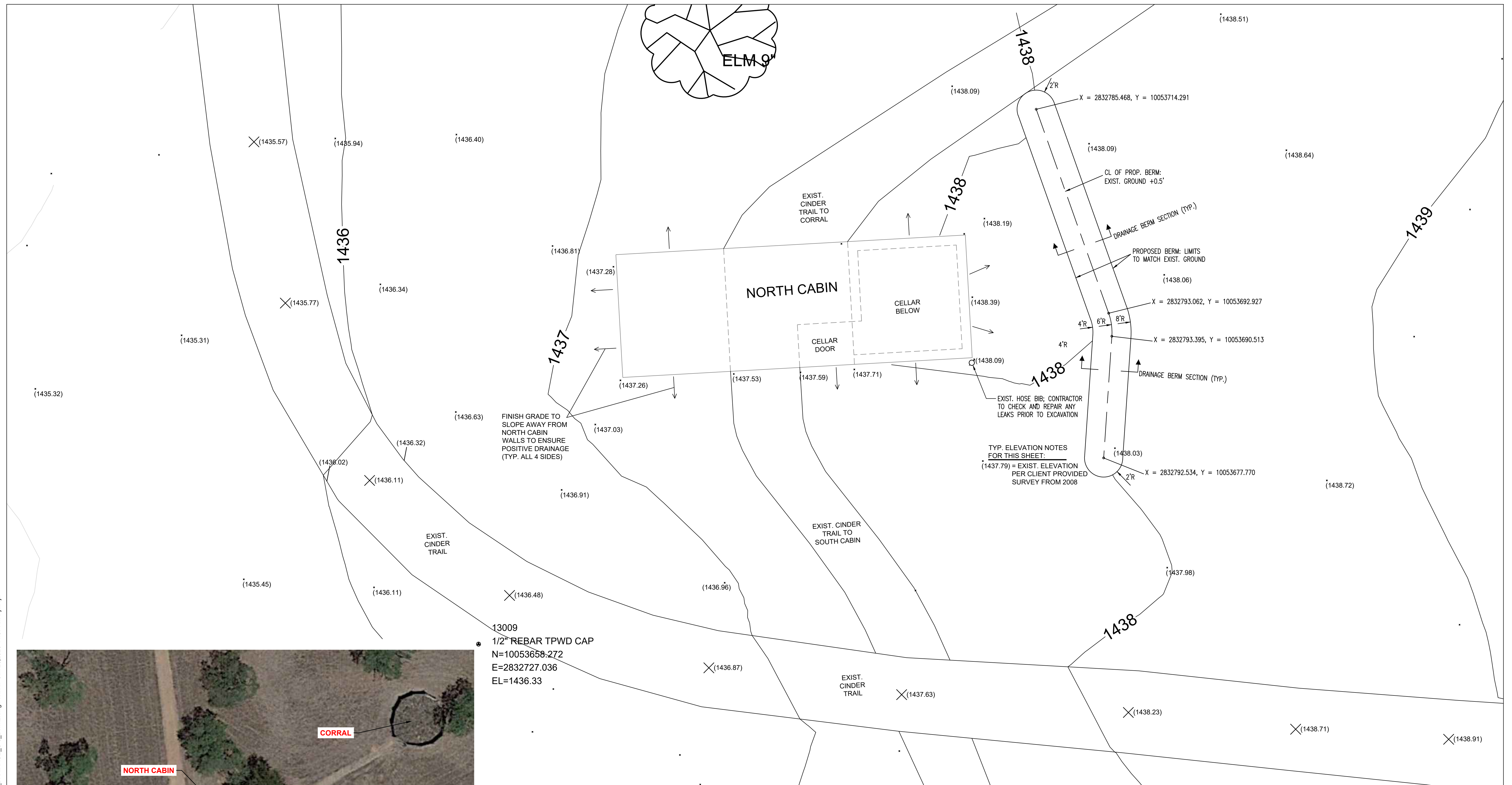
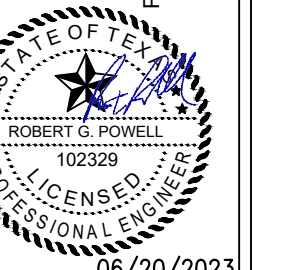

I:\R319793.01 - TPWD PSA 817522 - Historical Projects\10 CAD & BIM\10.1 AutoCAD\DWG\SHEET\B\19319793.01_DRAINAGE_C-3_Berm2.dwg Plotted: Jun 20, 2023 11:37 AM bljubaja

TREE PRESERVATION NOTES:

1. ALL TREES ARE TO REMAIN UNLESS DESIGNATED FOR REMOVAL ON DEMO PLANS. PRIOR TO CONSTRUCTION, PRESERVATION FENCING SHALL BE INSTALLED AT THE DRIP LINE OF ALL TREES OR TREE GROUPS TO REMAIN. TREE PROTECTION FENCE SHALL REMAIN THROUGHOUT CONSTRUCTION.
2. SOME PROPOSED WORK WILL REQUIRE DEMOLITION OR NEW CONSTRUCTION WITHIN LIMITS OF TREE CANOPY DEPICTED ON PLAN. IN THESE CIRCUMSTANCES, CONTRACTOR SHALL STRATEGICALLY LOCATE PRESERVATION FENCE INSIDE THE DRIP LINE BALANCING NEED TO PROVIDE ROOM FOR PERFORMANCE OF PROPOSED WORK WHILE MAINTAINING TREE HEALTH. CONTRACTOR SHALL NOTIFY OWNER OR LANDSCAPE ARCHITECT IF PROPOSED CONSTRUCTION THREATENS THE HEALTH OF A TREE.
3. APPROXIMATE EXTENTS OF TREE PRESERVATION FENCE IS SHOWN ON PLAN. ACTUAL LIMITS MAY VARY ACCORDING TO FIELD CONDITIONS.
4. PARKING OF VEHICLES OR PERFORMING WORK WITHIN PRESERVATION AREAS OTHER THAN WORK SHOWN ON THE PLAN WILL NOT BE ALLOWED.
5. NO FILL OR EXCAVATION OF ANY NATURE SHALL OCCUR WITHIN THE DRIP LINE OF A TREE TO BE PRESERVED, UNLESS THERE IS A SPECIFIED GRADE CHANGE SHOWN ON THE GRADING PLANS.
6. DISPOSAL OF ANY WASTE MATERIAL SUCH AS, BUT NOT LIMITED TO PAINT, ASPHALT, OIL SOLVENTS, CONCRETE, MORTAR, ETC WITHIN THE CANOPY AREA OF EXISTING TREES SHALL NOT BE ALLOWED.
7. NO ATTACHMENTS OR WIRES OF ANY KIND OTHER THAN THOSE OF A PROTECTIVE NATURE SHALL BE ATTACHED TO ANY TREE.
8. NO MATERIALS SHALL BE STORED WITHIN THE DRIP LINE AREA OF A TREE TO BE PRESERVED.

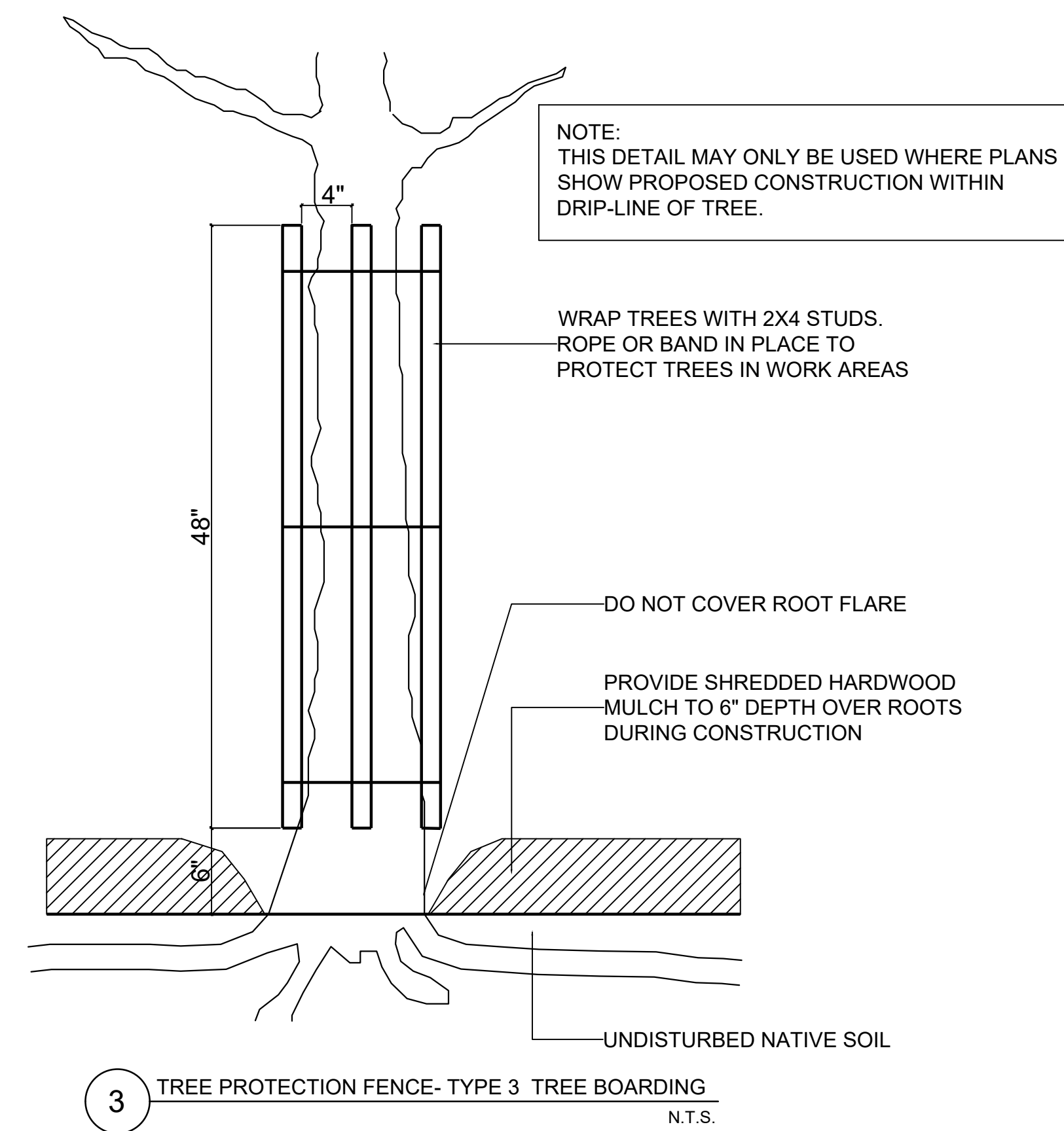
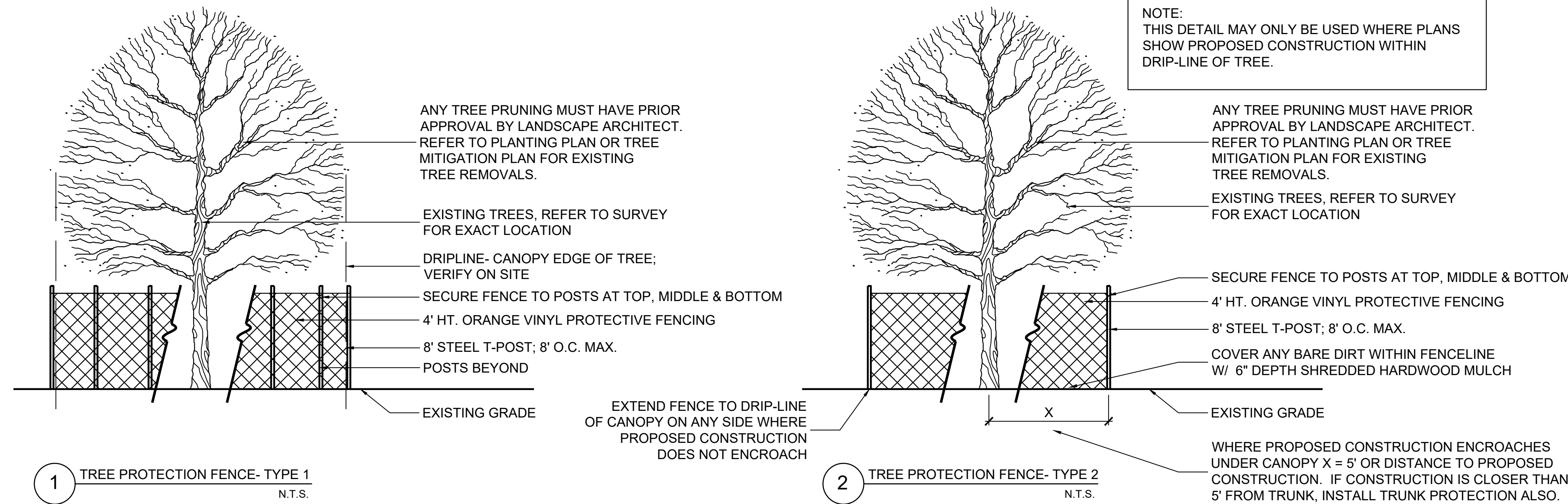



3 NORTH CABIN – NORTH ELEVATION
A-1|A-1 N.T.S.



5 NORTH CABIN – WEST ELEVATION
A-1|A-1 N.T.S.

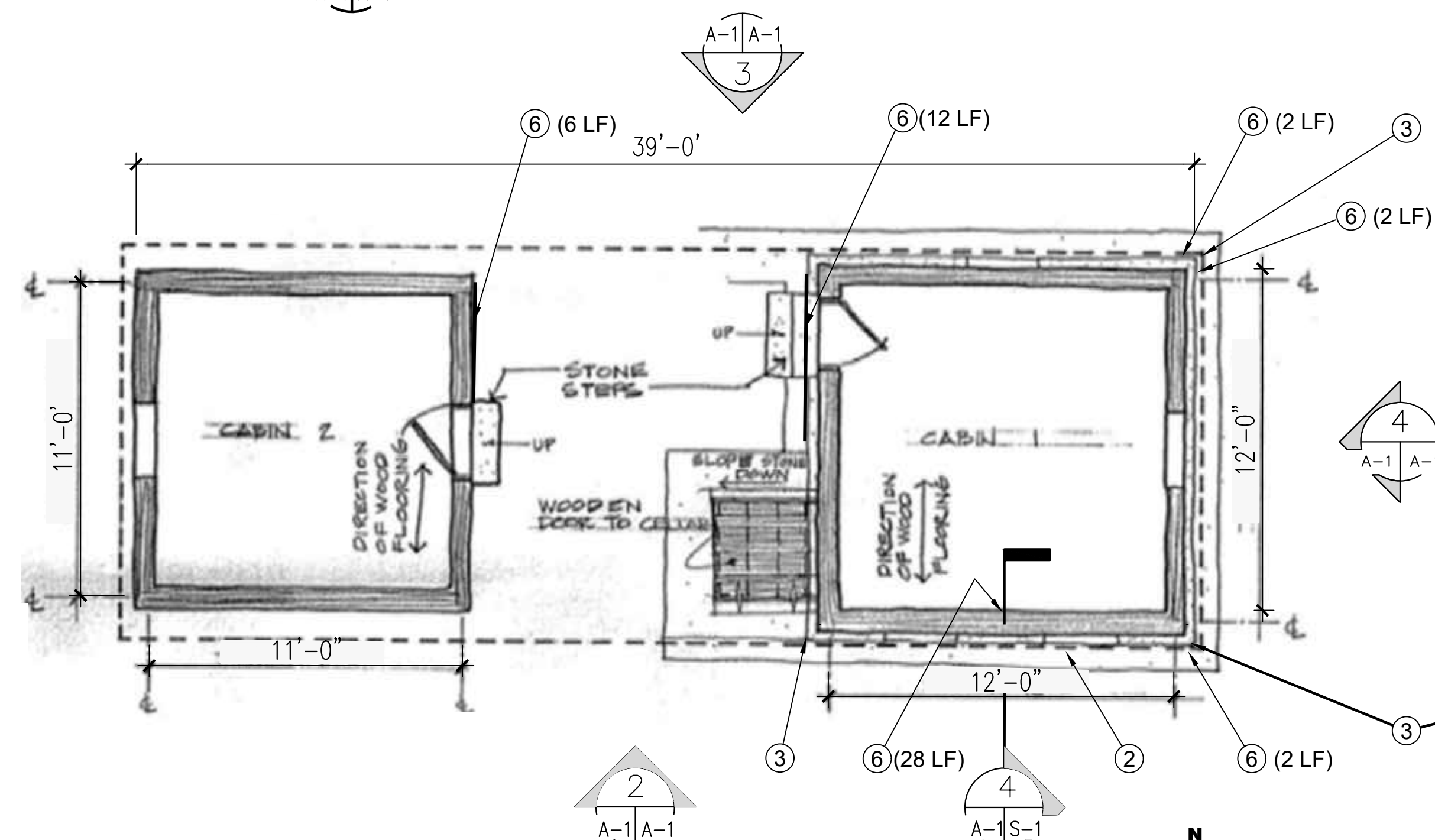

1 NORTH CABIN PLAN
A-1|A-1 N.T.S.



4 NORTH CABIN – EAST ELEVATION
A-1|A-1 N.T.S.



2 NORTH CABIN – SOUTH ELEVATION
A-1|A-1 N.T.S.

NORTH CABIN KEYED NOTES

- 1 SEE SITE PLAN C-2 FOR KEYED NOTES ON SCOPE OF WORK, PROTECTION, AND RESTORATION.
- 2 SEE S-1 FOR PROPOSED CONCRETE BARRIER WALL ON SOUTH SIDE OF EXISTING SOUTH CELLAR WALL.
- 3 SEE S-1 FOR PROPOSED HELICAL PILE LOCATIONS AND DETAILS.
- 4 SEE C-3 KEYED NOTE REGARDING EXIST. HOSE BIB.
- 5 FINAL GRADE TO SLOPE AWAY FROM WALLS TO ENSURE POSITIVE DRAINAGE; INSTALL BUFFALO GRASS SOD AROUND CABIN TO 8-FT OUT FROM ALL 4 WALLS; OMIT SOD AT CINDER TRAILS & RESTORE PRE-CONSTRUCTION ELEVATIONS.
- 6 REPAIR CRACK IN MORTAR AT OR IN FOUNDATION AND STEPS (LENGTH OF REPAIR). PERFORM CRACK REPAIR AFTER COMPLETION OF STRUCTURAL STABILIZATION WORK (SEE S-1).

DATE: 06/20/2023
DESIGNED BY: RGP
DRAWN BY: RGP
REVIEWED BY: GRW
REVISED:
REVISED:

SHEET TITLE
NORTH CABIN
PLAN AND
ELEVATIONS

SHEET NUMBER

A-1
SHEET 7 of 10



3 SOUTH CABIN – NORTH ELEVATION
A-2|A-2 N.T.S.



5 SOUTH CABIN – WEST ELEVATION
A-2|A-1 N.T.S.

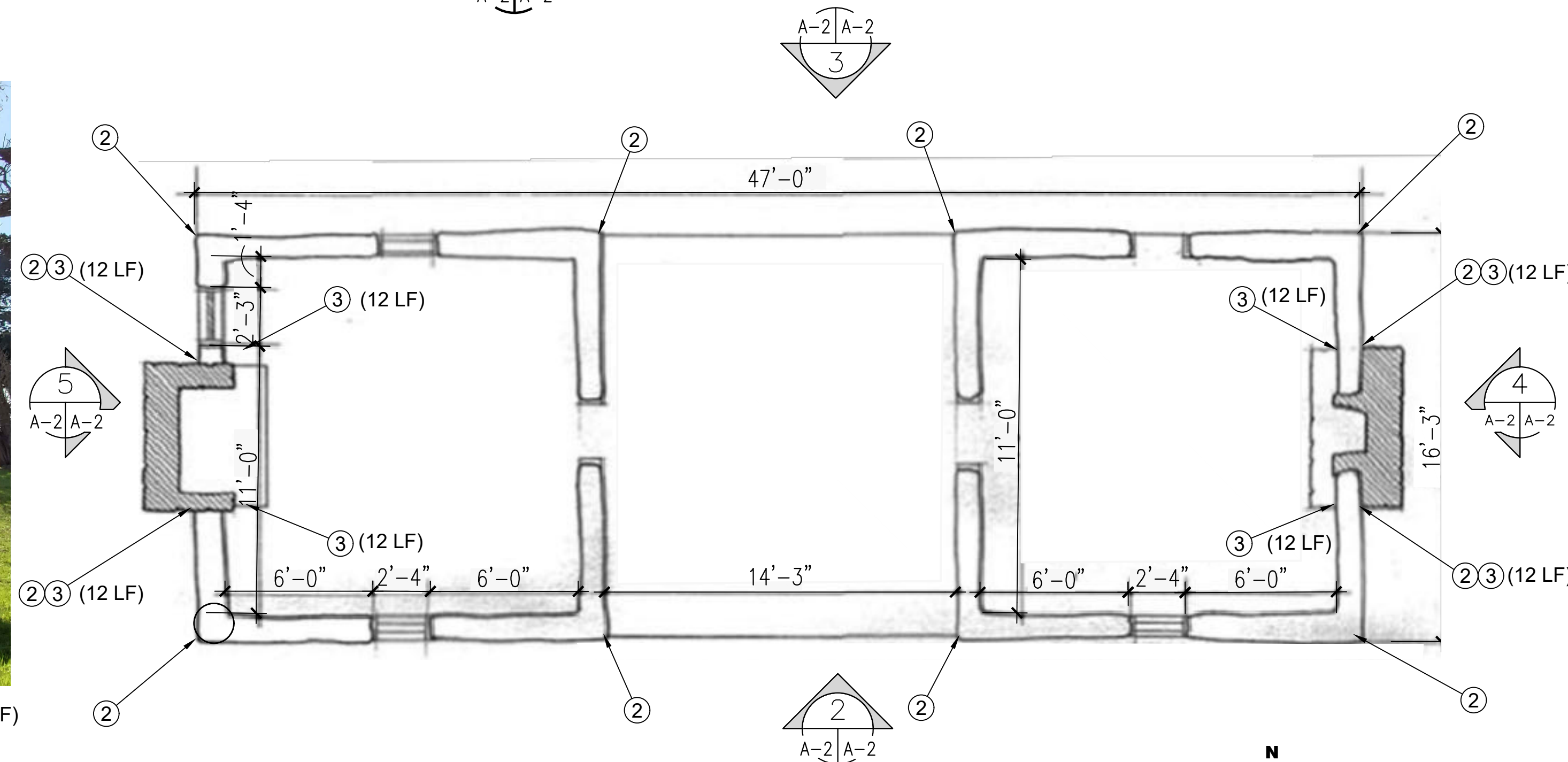

1 SOUTH CABIN PLAN
A-2|A-2 N.T.S.



4 SOUTH CABIN – EAST ELEVATION
A-2|A-2 N.T.S.

3 (12 LF) ALSO ON OPPOSITE (NORTH) SIDE OF CHIMNEY



2 SOUTH CABIN – SOUTH ELEVATION
A-2|A-2 N.T.S.

SOUTH CABIN KEYED NOTES

- ① SEE SITE PLAN C-2 FOR KEYED NOTES ON SCOPE OF WORK, PROTECTION, AND RESTORATION.
- ② SEE S-1 FOR PROPOSED HELICAL PILE LOCATIONS AND DETAILS.
- ③ SOUTH CABIN CRACK REPAIRS: PERFORM REPAIRS BOTH INSIDE AND OUTSIDE THE CABIN AT LOCATIONS NOTED. PERFORM MORTAR/CRACK REPAIRS AFTER COMPLETION OF STRUCTURAL STABILIZATION WORK (SEE S-1). (LENGTH OF REPAIR)

I:\R319793.01 - TPWD PSA 817522 - Historical Projects\10 CADDD & BIM\10.1 AutoCAD\DWG\SHEET\B\19793.01_CABIN PLANS_A-2 SOUTH_LR1.dwg Plotted: Jun 20, 2023 - 11:39 AM bjloja

DATE: 06/20/2023
DESIGNED BY: RGP
DRAWN BY: RGP
REVIEWED BY: GRW
REVISED:
REVISED:

SHEET TITLE
SOUTH CABIN
PLAN AND
ELEVATIONS

SHEET NUMBER

A-2

SHEET 8 of 10

100% CONSTRUCTION DOCUMENTS

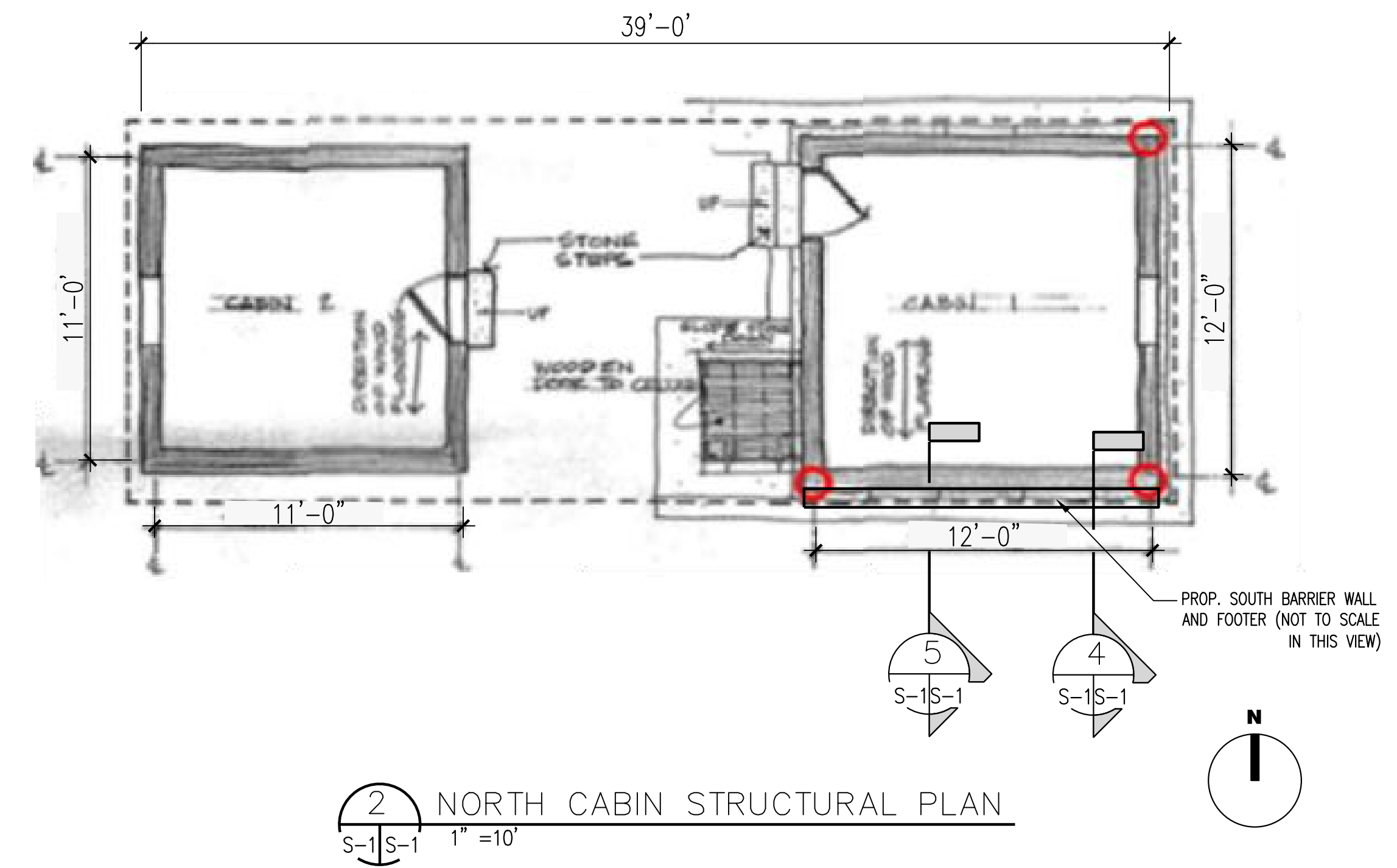
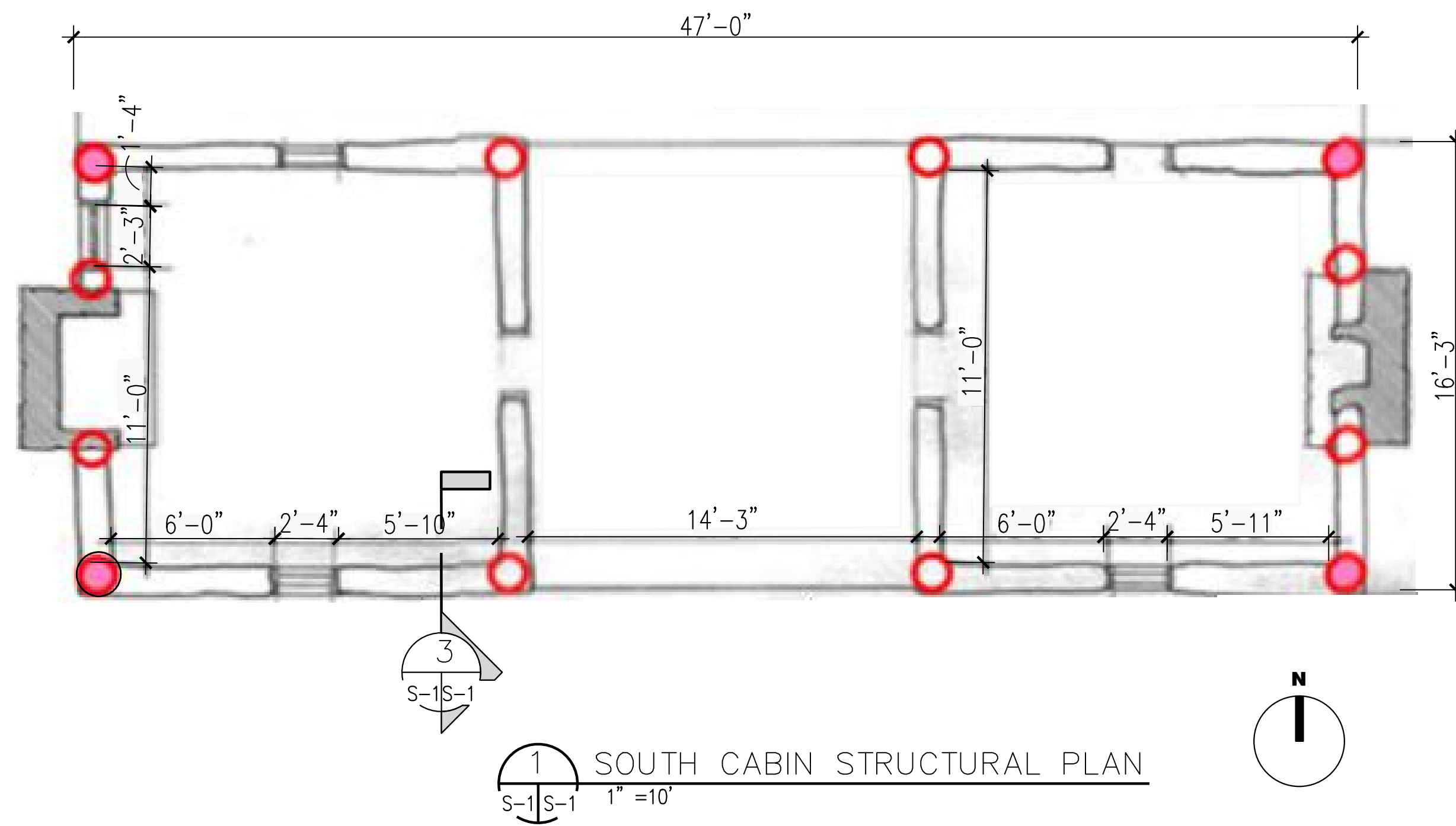

INDICATES LOCATION OF HELICAL PIERS

CRITICAL PIER LOCATIONS AT SOUTH CABIN; INSTALL THESE BEFORE OTHERS

NOTE	DESCRIPTION
1.	HELICAL PILES SHALL BE DESIGNED AND MANUFACTURED IN ACCORDANCE WITH THE CURRENT INTERNATIONAL BUILDING CODE (IBC) ADOPTED BY THE LOCAL JURISDICTION.
2.	HELICAL PILES SHALL BE (BASIS OF DESIGN) CHANCE, RS 2875.203, 2.875", 10X7 FT, GALV. OR APPROVED EQUAL.
3.	HELICAL PILE SHALL BE RECOGNIZED BY ICC AND THE MANUFACTURER SHALL HOLD A CURRENT ICC-ES ESR REPORT SHOWING COMPLIANCE WITH AC308 AND CURRENT INTERNATIONAL BUILDING CODE (IBC) ADOPTED BY THE LOCAL JURISDICTION.
4.	DIMENSIONS OF THE CENTRAL SHAFT AND THE NUMBER, SIZE, SPACING AND THICKNESS OF THE HELICAL BEARING PLATES SHALL BE DESIGNED AND FABRICATED TO SUPPORT THE SPECIFIED DESIGN LOADS.
5.	ONLY ROUND CENTRAL PILE SHAFTS WILL BE ALLOWED.
6.	MINIMUM AND MAXIMUM INSTALLATION TORQUES SHALL BE SPECIFIED BY THE HELICAL PILE MANUFACTURER. THE MINIMUM INSTALLATION TORQUE SHALL BE HIGH ENOUGH TO ACHIEVE THE REQUIRED BEARING CAPACITY, INCLUDING A SAFETY FACTOR OF 2. THE MAXIMUM INSTALLATION TORQUE SHALL NOT EXCEED THE ALLOWABLE TORSIONAL CAPACITY OF THE PILE SHAFTS.
7.	HELICAL PILES SHALL BE DESIGNED AND MANUFACTURED TO RESIST ALL STRESSES INDUCED BY INSTALLATION.
8.	EXISTING CONDITIONS AND UNDERGROUND OBSTRUCTIONS SHALL BE CONFIRMED BY THE PILE INSTALLER. PROBING OR SCANNING MAY BE NECESSARY TO LOCATE UNDERGROUND OBSTRUCTIONS. REPORT ANY UNFORESEEN OBSTRUCTIONS TO THE STRUCTURAL ENGINEER.
9.	LOCATIONS OF PILES SHALL NOT BE CHANGED WITHOUT WRITTEN APPROVAL FROM THE STRUCTURAL ENGINEER.
10.	SPECIAL INSPECTION OF THE HELICAL PILE INSTALLATION SHALL BE PERFORMED IN ACCORDANCE WITH SECTION 1705.9 OF THE 2021 IBC UNLESS EXCEPTIONS NOTED IN SECTION 1704.2 OF IBC ARE MET. THE INSPECTOR SHALL RECORD THE FOLLOWING: A. INSTALLATION DATE. B. PILE MANUFACTURER. C. INSTALLATION CONTRACTOR. D. IDENTIFICATION OF INSTALLATION EQUIPMENT. E. MINIMUM ALLOWABLE INSTALLATION TORQUE. F. MAXIMUM ALLOWABLE INSTALLATION TORQUE. G. CENTRAL SHAFT DIAMETER OF EACH PILE. H. HELIX PLATE CONFIGURATION OF EACH PILE. I. ACTUAL TIP EMBEDMENT OF EACH PILE. J. ACTUAL INSTALLATION TORQUE OF EACH PILE. K. ULTIMATE CAPACITY OF EACH PILE AS SPECIFIED BY MANUFACTURER. L. ALLOWABLE CAPACITY OF EACH PILE AS SPECIFIED BY MANUFACTURER.

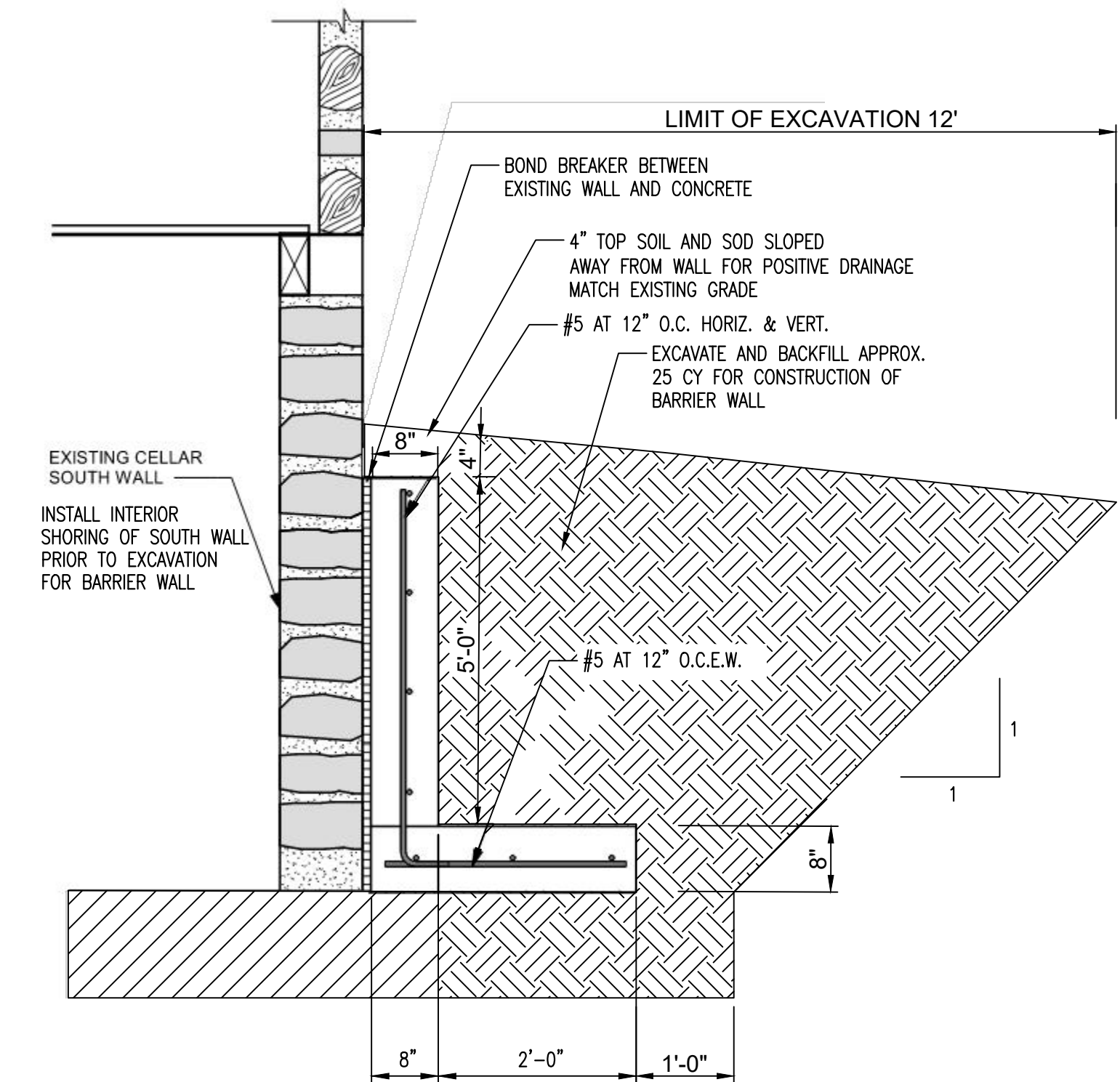
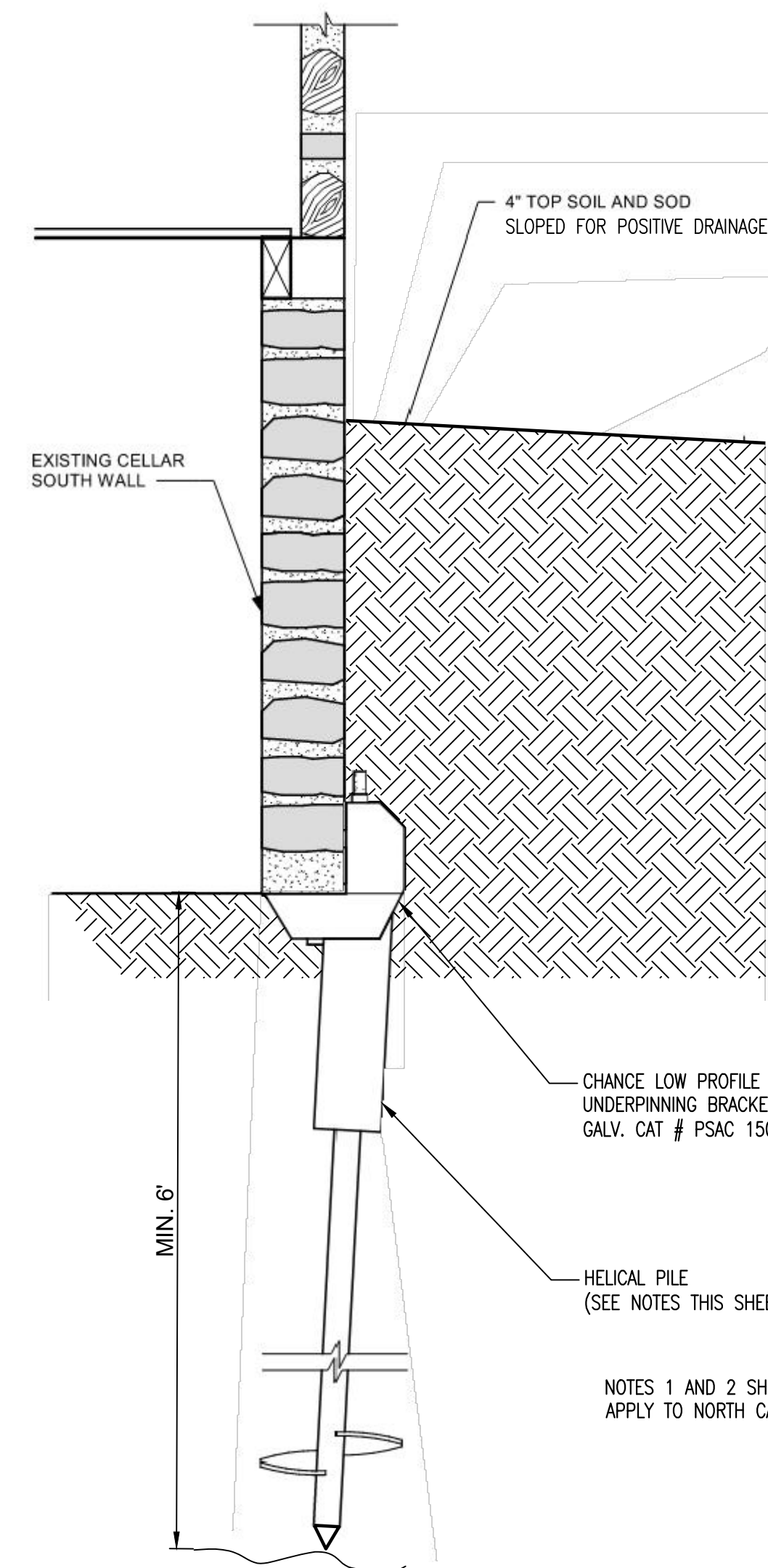
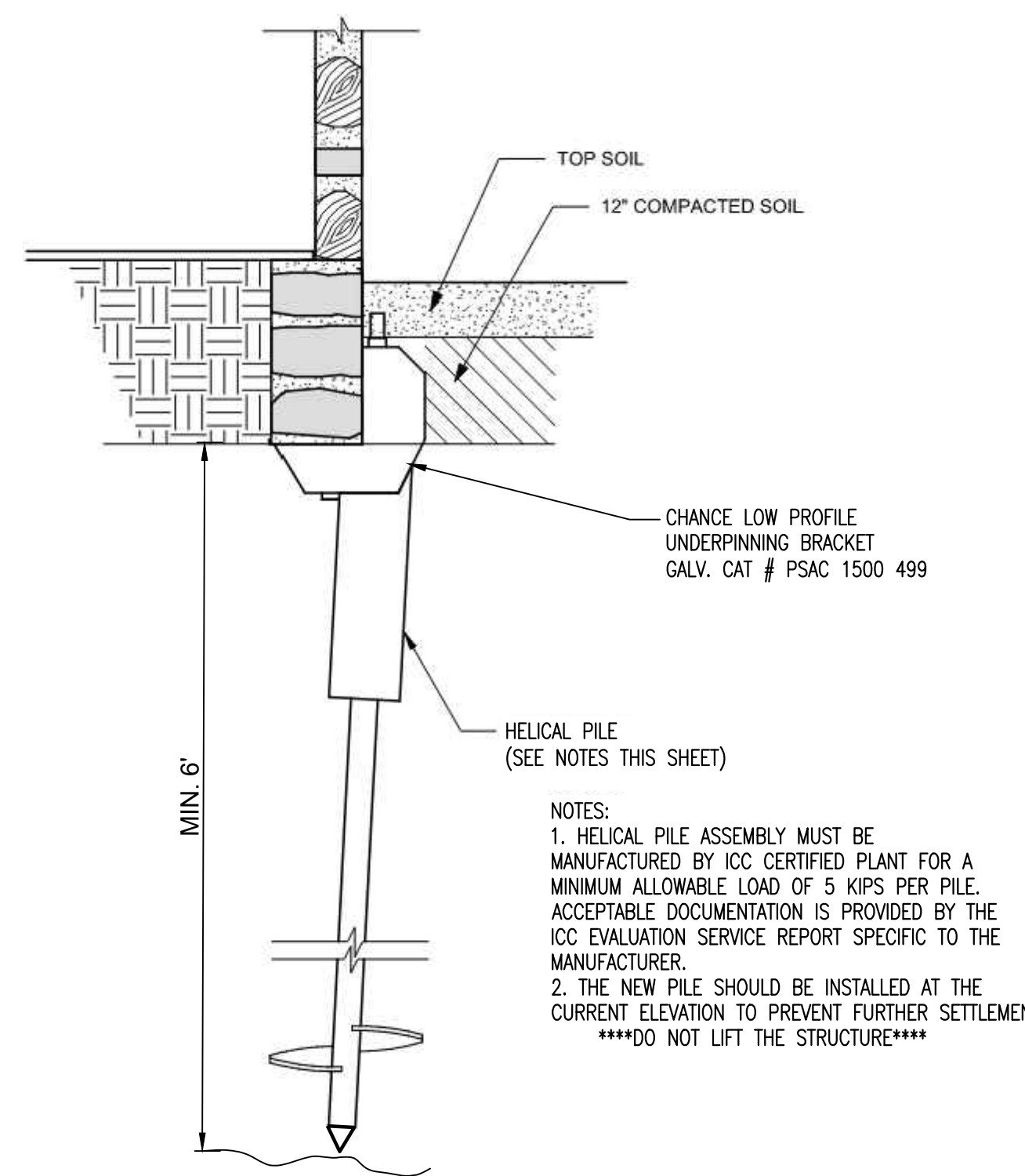

- STRUCTURAL NOTES:
- SUBMIT PRODUCT DATA ON PROPOSED HELICAL PILES AND ACCESSORIES.
 - MATCH EXISTING MORTAR FOR COLOR AND TEXTURE; SUBMIT PRODUCT DATA AND COLOR SAMPLES ON PROPOSED MORTAR FOR REVIEW AND SELECTION.
 - PERFORM MORTAR REPAIRS AFTER COMPLETION OF STRUCTURAL STABILIZATION WORK.
 - CONTRACTOR TO PROVIDE TEMPORARY SUPPORTS FOR EXISTING BUILDING WALLS PRIOR TO EXCAVATING FOR INSTALLATION OF CONCRETE BARRIER WALL AND FOOTER, HELICAL PILES, AND UNDER-FOOTING HELICAL PILE BRACKETS.
 - CONCRETE MIX SHOULD BE TREMIED TO THE BOTTOM OF THE BARRIER WALL FORMS. THE MAXIMUM FREE FALL OF THE PLASTIC CONCRETE SHALL NOT EXCEED 6-FEET.
 - CONTRACTOR SHALL UTILIZE A MATERIALS TESTING LABORATORY TO DETERMINE SUITABILITY OF EXCAVATED MATERIAL FOR RE-USE. BACKFILL SHALL BE ON-SITE CLAYS PROPERLY COMPACTED TO A MINIMUM OF 95 PERCENT OF ASTM D 698 AT A MINIMUM OF 2 PERCENTAGE POINTS ABOVE THE OPTIMUM MOISTURE DETERMINED BY THAT TEST.

NORTH CABIN CELLAR SOUTH WALL DETAIL
LINE1
LINE2



A NORTH CABIN SOUTH WALL



B NORTH CABIN SE CORNER



C NORTH CABIN NE CORNER



D NORTH CABIN CELLAR SOUTH WALL
NO WORK PROPOSED INSIDE CELLAR OTHER THAN TEMP. SHORING IN ACCORANCE WITH KEYED NOTES 2 AND 3 ON DRAWING C-2.

NORTH CABIN KEYED NOTES (SEE DRAWING A-1)

- ① SEE SITE PLAN C-2 FOR KEYED NOTES ON SCOPE OF WORK, PROTECTION, AND RESTORATION.
- ② SEE S-1 FOR PROPOSED CONCRETE BARRIER WALL ON SOUTH SIDE OF EXISTING SOUTH CELLAR WALL.
- ③ SEE S-1 FOR PROPOSED HELICAL PILE LOCATIONS AND DETAILS.
- ④ SEE C-3 KEYED NOTE REGARDING EXIST. HOSE BIB.
- ⑤ FINAL GRADE TO SLOPE AWAY FROM WALLS TO ENSURE POSITIVE DRAINAGE; INSTALL BUFFALO GRASS SOD AROUND CABIN TO 8-FT OUT FROM ALL 4 WALLS; OMIT SOD AT CINDER TRAILS & RESTORE PRE-CONSTRUCTION ELEVATIONS.



E SOUTH CABIN NW CORNER



F SOUTH CABIN SW CORNER

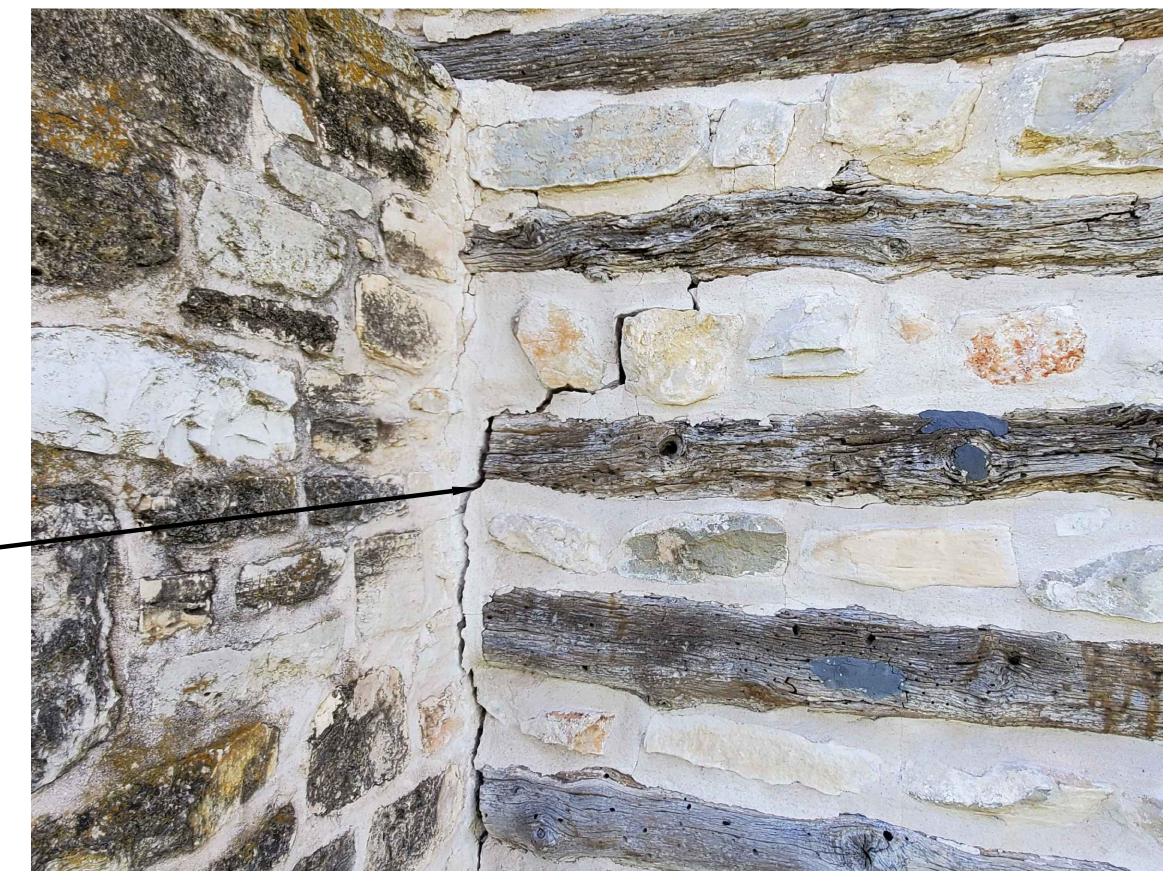

G SOUTH CABIN WEST END CHIMNEY

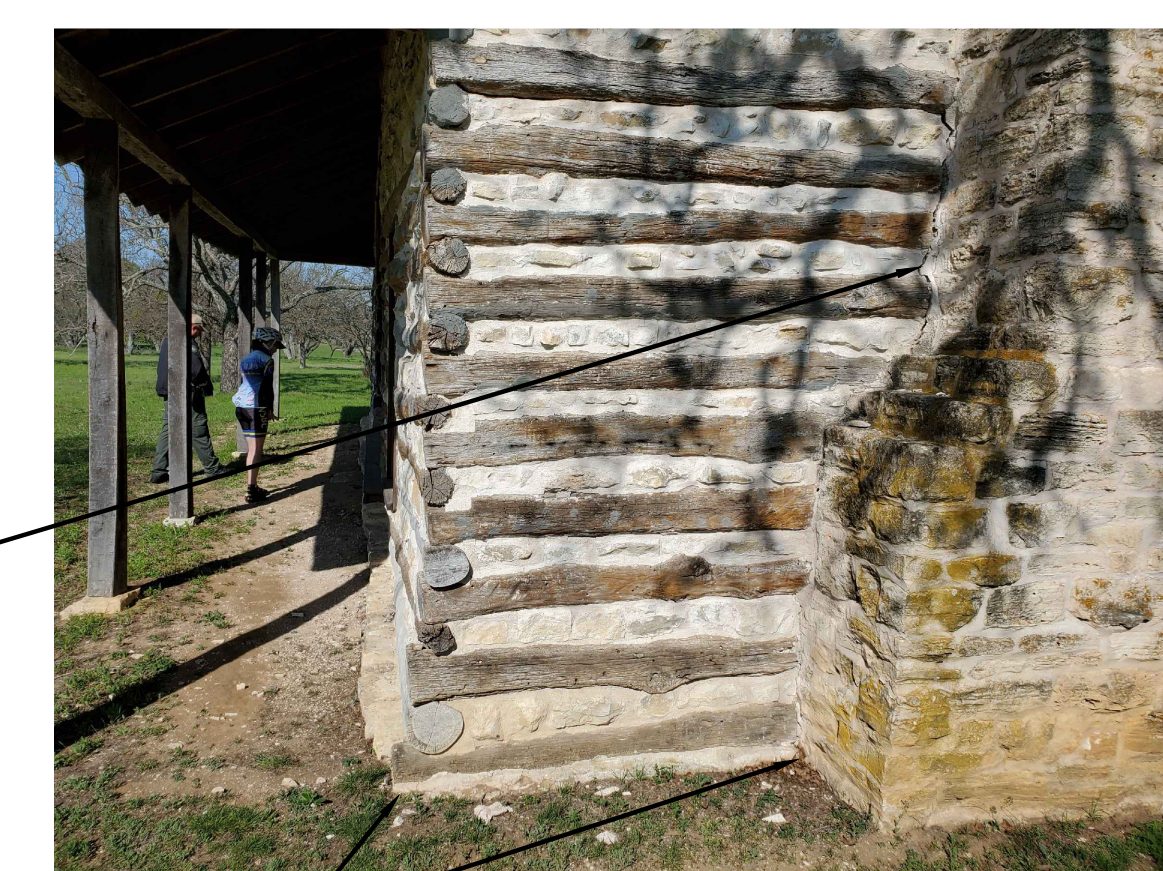

H SOUTH CABIN SE CORNER

SOUTH CABIN KEYED NOTES (SEE DRAWING A-2)

- ⑥ SEE SITE PLAN C-2 FOR KEYED NOTES ON SCOPE OF WORK, PROTECTION, AND RESTORATION.
- ⑦ SEE S-1 FOR PROPOSED HELICAL PILE LOCATIONS AND DETAILS.
- ⑧ SOUTH CABIN CRACK REPAIRS: SUBMIT PROPOSED MORTAR MIX DESIGN FOR REVIEW AND APPROVAL; MATCH COLOR AND TEXTURE OF EXISTING HISTORICAL MORTAR FOR SOUTH CABIN. PERFORM REPAIRS BOTH INSIDE AND OUTSIDE THE CABIN AT LOCATIONS NOTED. PERFORM MORTAR/CRACK REPAIRS AFTER COMPLETION OF STRUCTURAL STABILIZATION WORK (SEE S-1).

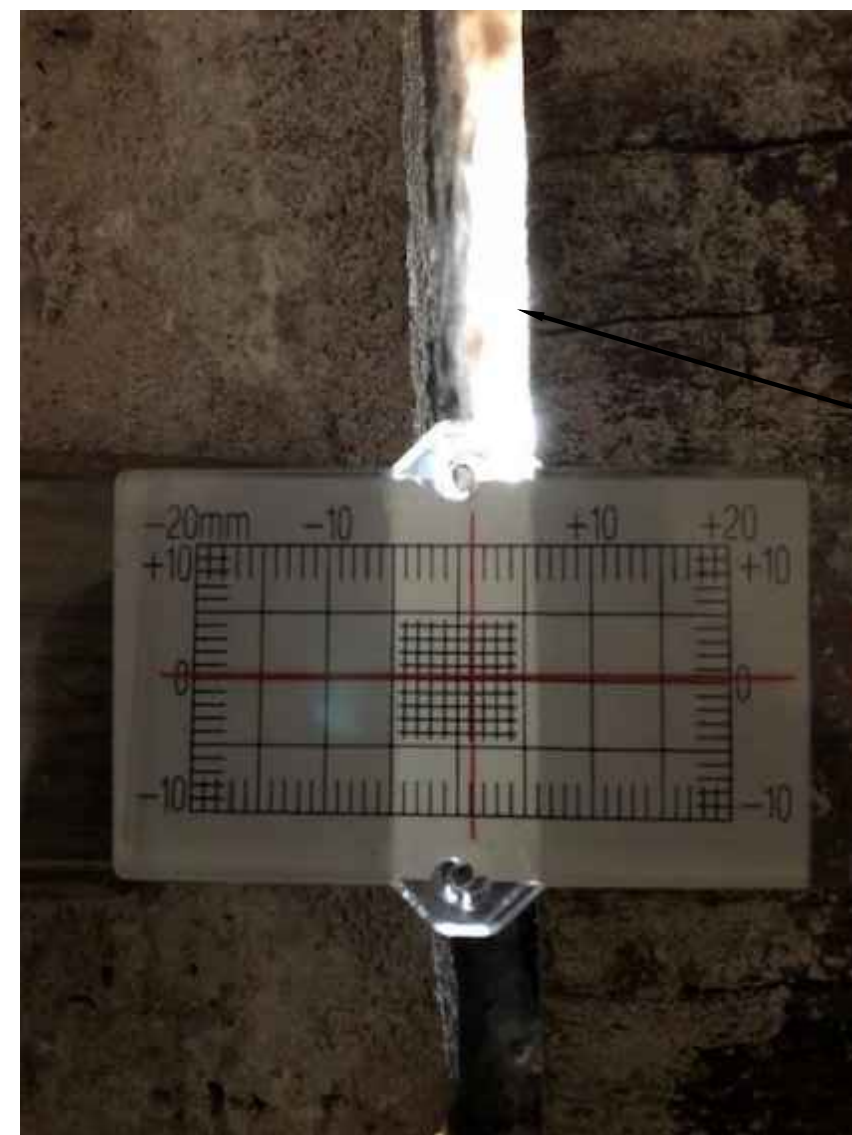

I SOUTH CABIN LOOKING FROM INSIDE
LOOKING OUT THROUGH CRACK AT CHIMNEY

EXHIBITS TO THE CONTRACT

EXHIBIT A

HUB SUBCONTRACTING OPPORTUNITIES (FORM
PWD 0991) & LIST OF HUB CERTIFIED VENDORS
BY STATE CLASS & ITEM CODE



Infrastructure HUB Subcontracting Opportunities

Date of HUB List: 01/18/2024 **Project/Contract Number:** CR11387R

Description: Lyndon B. Johnson State Park Danz Cabins Repairs

In accordance with Texas Administrative Code, Title 34, Part 1, Chapter 20, Subchapter D, Division 1, state agencies shall make a good faith effort to utilize Historically Underutilized Businesses (HUBs) in contracts for Construction, Services (including Professional and Consulting Services), and Commodity procurements. The State of Texas Policy is to contract directly with HUBs or indirectly through subcontracting opportunities. Each Contractor/Vendor shall also make a good faith effort to utilize HUBs in subcontracting opportunities.

TPWD estimates the value of this contract to be \$ 138,530 and further sets the HUB subcontracting goal at 11.2 % of the contract's value.

(Subcontractor - A person who contracts with a vendor to work, to supply commodities, or contribute toward completing work for a governmental entity as defined in Texas Government Code 2251.001.)

NOTE: The following list identifies potential subcontracting opportunities. You could have other opportunities or may self-perform some opportunities. You are not required to subcontract every potential subcontracting opportunity.

Class & Item Code: Trades/Disciplines/Major Supplies:	Class & Item Code: Trades/Disciplines/Major Supplies:
910-51 Masonry, Concrete, and Stucco Maintenance, Finishing, and Repair Services Including Inside Concrete Sawing and Grouting Work	
910-71 Shoring and Reinforcement Services	
912-23 Construction, General: Backfill Services, Digging, Ditching, Road Grading, Rock Stabilization, etc.	
912-44 Excavation Services	
913-48 Construction, Special Foundation	

HUB LIST:

TPWD does not endorse, recommend or attest to the capabilities of any company or individual listed. The list is strictly provided as a convenience to respondents.

Respondents may also access a list of HUB subcontractors by referencing the above Class and Item codes in a Centralized Master Bidders List (CMBL) search at <https://mycpa.cpa.state.tx.us/tpasscmbsearch/index.jsp>.

Comptroller HSP information: <https://www.comptroller.texas.gov/purchasing/vendor/hub/forms.php>.

A few minority and women trade organizations and development centers are listed below. For a more complete list, please visit <https://www.comptroller.texas.gov/purchasing/vendor/hub/resources.php>.

National Association of Minority Contractors, Inc. – Greater Houston 1337 W. 43 rd St., Ste. B165 Houston, TX 77018 (832) 797-1842 phone execufirm1@yahoo.com email www.namctexas.org website	Texas Association of African American Chambers of Commerce 807 Brazos St., Ste. 710 Austin, TX 78701 (512) 535-5610 phone info@taaacc.org email www.taaacc.org website	Texas Association of Mexican American Chambers of Commerce 606 Main St. Buda, TX 78610 (512) 444-5727 phone president@tamacc.org email www.tamacc.org website
Asian Contractor Association 7600 Chevy Chase Dr., Ste. 300 Austin, TX 78752 (512) 926-5400 phone (512) 926-5410 fax asiancontractor@gmail.com email www.acta-austin.com website	Women’s Business Council - Southwest 5605 N. MacArthur Blvd., Ste. 220 Irving, TX 75038 (866) 451-5997 office (toll free) (817) 299-0949 fax info@wbcsouthwest.org email www.wbcsouthwest.org website	Women’s Business Enterprise Alliance 9800 Northwest Freeway, Ste. 120 Houston, TX 77092 (713) 681-9232 office (713) 681-9242 fax bids@wbea-texas.org email www.wbea-texas.org website

For information on the TPWD HUB program, assistance with completing forms, or to obtain HUB lists if web access is not possible, please contact the TPWD HUB staff at (512) 389-4784 or hub@tpwd.texas.gov.

Results for HUBs for 910-51 : Masonry, Concrete, and Stucco Maintenance, Finishing, and Repair Services Including Inside Concrete Sawing and Grouting Work

Vendor ID	Company Name	Contact Person	City	Email	Phone	Business Description	HUB Eligibility	HUB Gender	CMBL Stat	HUB Status
1475357271900	1DZ ENTERPRISE LLC	Debra A. Garcia	ARANSAS PASS	debbiegarc20@gmail.com	361-534-4244	Janitorial Service, Construction Cleanup, Site Preparation, Demolition, Demolition Cleanup,Paving, General Construction, Concrete Work	HI	F	No	Yes
1452593440300	3 FARMER ENTERPRISES, INC.	Darren Farmer	TYLER	farmerenterprise@hotmail.com	903-571-4687	Construction: General Commercial & Remodel Residential,Commercial,Concrete,Roofing, Gutters,Dump truck services,Hauling	BL	M	No	Yes
1461995281600	360 TXC, LLC	Tony LESTER	AUSTIN	dlester@360txc.com	512-229-6440	We provide general contracting and complete project planning and management services. Our vast project portfolio covers everything from 1,000sqft interiors and renovations to 25,000sqft+ ground-up and core-shell buildouts.	BL	F	No	Yes
1842115429700	9 Ether Global Services, LLC	Ariel Mitchell	Houston	9etherglobal@gmail.com	832-236-7497	General contracting services. Also provide the following trade services: drywall, framing, ceiling, painting, flooring, specialties, carpentry, Division 9 & 10, etc.	BL	M	No	Yes
1823604961700	A D WELDING, INC.	arthur B Dirden	HOUSTON	a.dwelding.180llc@gmail.com	832-520-8495	Fabrication welding and fitting of pipes stainless steel and carbon pipes. Oilfield and pipeline fabrication in addition to repairs on water side/pipes.	BL	M	Yes	Yes
1271548520200	A-PLUS SEALANTS, INC.	PRESIDENT/Terrisia Schier	AUSTIN	aplussealants@hotmail.com	512-454-3388	Sealants,waterproofing,firestopping>window cleaning and special coatings.	WO	F	No	Yes
1923355319700	ABH PROS LLP	Allison Lopez	SAN ANTONIO	contact@abhpros.com	866-777-7310	BUILDING CONSTRUCTION SERVICES, NEW (INCL. MAINTENANCE AND REPAIR SERVICES); BUILDING MAINTENANCE, INSTALLATION AND REPAIR SERVICES; CONSTRUCTION SERVICES, GENERAL (INCL. MAINTENANCE AND REPAIR SERVICES); CONSTRUCTION SERVICES, TRADES, NEW CONSTRUCTION;	HI	F	Yes	Yes
1752917422300	ACS CONTRACTORS	PresMary P Gorsage	ROWLETT	marygorsage@acscontractors.com	972-463-8767	Commercial concrete subcontractor specializing in set-up place and finish of paving, foundation, AS flatwork, structural slabs and tilt wall	AS	F	No	Yes
1752966405800	ACUMEN ENTERPRISES, INC.	Wayne Boyter	DESOTO	wayne@acumen-enterprises.com	972-572-0701	Mechanical HVAC & plumbing contractor, mechanical insulation, & general construction	AI	M	Yes	Yes
1752856954800	ADVANCED ROOFING SERVICES, INC.	Cruz Mendez	LONGVIEW	sammie@advancedroofingservices.com	903-759-9298	commercial, residential and industrial roofing. Weatherproofing. Custom sheetmetal. Also do demolition work.	HI	M	Yes	Yes
1833434740000	AGCE CORP	PresAnthony Gutierrez	HORSESHOE BAY	ag@agcecorp.us	512-529-5851	Abatement, Demolition, Concrete and Masonry.	HI	M	No	Yes
1830850762500	ALPC, LLC	J. Americo Rovelo	HOUSTON	alpcx@comcast.net	713-896-0778	Commercial Landscape & irrigation construction, maintenance and services.	HI	M	Yes	Yes
1830401299200	AO GENERAL CONTRACTOR, INC.	ABELARDO OLIVAS	EL PASO	polivas@aogcon.com	915-860-4871	BUILDING CONSTRUCTION SERVICES.	HI	M	No	Yes
1760110237300	AQUATEX WATER CONDITIONING, INC.	NANCY STANDEFORD	ALVIN	nls@aquatexwater.com	281-331-7777	water softening, filtration and purification, sales and service.	WO	F	No	Yes
1461387592200	ARS SPECIALTY CONTRACTORS, LLC	Elizabeth Yetman Chavez	SAN ANTONIO	elizabeth@garrentx.com	210-736-4224	Our company provides high-quality construction services in the areas of general contracting, federal prime contracting as well as subcontracting in the areas of industrial coatings, large scale concrete construction, and gypsum underlayment and lightweight	HI	F	No	Yes
1742723787400	ASD CONSULTANTS INC	Curtis Brown	AUSTIN	curtis2aia@gmail.com	512-836-3329	General Contractors,Cost Estimators,Construction Inspection	BL	M	Yes	Yes

1204458359400	AZTECA DESIGNS, INC	CECILIA A. CASTELLANO	SOMERSET	marketing@aztecadesigns.com	210-375-1900	A General Construction Company that specializes in all in interior and exterior finishes. Flooring, walls, ceiling. Interior demolition and put back. Concrete work, asphalt work, parking lot striping, exterior painting, mowing and landscaping	HI	F	Yes	Yes
1262840040500	Austin Constructors, LLC	Marcos Medrano	Austin	jenny@austinconstructors.com	512-386-8690	To provide concrete, utility, sidewalk and heavy highway construction services. Firm also provide general construction and residential remodeling scopes.	HI	F	No	Yes
1884290552500	BADGER CONSTRUCTION GROUP LLC	Carlos Feliciano	IRVING	badgerconstructiontx@gmail.com	214-636-9581	Millwork, Carpentry, Flooring, Painting and Roofing	HI	M	Yes	Yes
1752686521100	BASECOM, INC.	President / Oscar Oaxaca	FORT WORTH	ooaxaca@basecominc.com	817-589-0050	Building Construction, Including General Contractors And Operative Builders, Electrical Contractor	HI	M	No	Yes
1273088856200	BASIC SDV, INC	Rich Barrick	AUSTIN	bids@basicsdv.com	512-827-6806	Job Order Contracting, JOC, General Contracting, Construction Management, Government Contracting, State Contracting, School Districts, Universities, Medical, Federal, Veterans Administration, IDIQ Contracting	DV	M	Yes	Yes
1464157976900	BBC CONSTRUCTION SERVICES	Veronica Chapa	LAREDO	veronicachp@yahoo.com	210-422-5558	Construction- install,tile,carpet,vct,concrete,sheetrock and metal works.	HI	F	No	Yes
1030503577501	BCL&D Services	Paul McGregor	Stafford	info@bclservicesllc.com	281-986-9656	Full services construction: Drywall, painting, flooring, electrical, plumbing, paving, landscaping, acoustical ceiling, masonry, etc.	BL	M	No	Yes
1920844529600	BRG GROUP LLC	Roger Gonzales	NEW BRAUNFELS	3brg.group@gmail.com	512-653-4340	Repair,ground maintenance,landscaping, fencing, capert, roofing, painting	HI	M	Yes	Yes
1824166801300	Bass Roofing & Restoration, LLC	Shelley Bassinger	Fort Worth	shelley@bassroof.com	888-407-6634		WO	F	No	Yes
1833220550100	Brick Stone Tile LLC		Irving	brickstonetile@gmail.com	469-321-7979		HI	F	No	Yes
1843835932700	C & C RESTORATION SERVICES, INC.	Victor Chaire	HILLSBORO	vchaire@ccrestorationservice.com	254-205-8060	Grouting, patching and restoration of precast concrete buildings	HI	M	No	Yes
1264137812500	C.C. ZAMORA CONSTRUCTION LLC	Pres./Linda Zamora	RIVER OAKS	LUPEZAMORA@ZAMORACONSTRUCTION.COM	817-759-0063	Provides commercial and residential electrical services, both new construction and repair/renovation projects.	HI	M	No	Yes
1263484785400	CAPTAIN CONSTRUCTION COMPANY LLC	Bobby Captain Owner Mgr.	MANSFIELD	Admin@cccbuilders.org	682-518-1448	We are experienced in roofing, plumbing, electrical, landscaping, concrete, flooring, general repair and remodeling to include modular trailer finish out.	BL	M	Yes	Yes
1752918306700	CARCON INDUSTRIES & CONSTRUCTION, LLC	Arcilia Acosta	DALLAS	aacosta@carconindustries.com	214-352-8515	GENERAL CONSTRUCTION SERVICES- CONSTRUCTION PRODUCTS PURCHASING- TELECOMMUNICATIONS SERVICES	HI	F	No	Yes
1823027227200	CASTRO CONTRACTOR SERVICES INC	JOSIAS CASTRO	HUMBLE	joe@castroconstructionservicesinc.com	281-785-1985	Construction Management	HI	M	Yes	Yes
1473191874500	CBMAA, Inc.	Christopher Patton	Forney	chris.patton@wellingtonfs.com	972-853-1455	General Contracting to include Project Management	BL	M	No	Yes
1830851049600	CDM7, LLC	Trey Harris	Spring	trey@cdmseven.com	713-253-2322	Construction Management, Project/Program Management	BL	M	No	Yes
1742919890000	CEDA-TEX SVCS INC	Fred Odanga	CEDAR PARK	contact@cedatex.com	512-339-0155	General construction. New construction, Site, drainage, Interior drywall, plumbing, electrical Painting ,concrete work etc	BL	M	Yes	Yes
1450602159200	CLL Specialists Corporation	Carol Loveless	San Antonio	info@renovatepaint.com	210-403-3232	Residential Remodelers, Addition, alteration and renovation, for-sale builders, commercial and institutional building, Drywall and Insulation Contractors, Painting and Wall Covering Contractors.	WO	F	No	Yes
1743003328600	COBOS DESIGN & CONSTRUCTION, INC.	CAL COBOS	AUSTIN	cdc@cobosinc.com	512-478-1986	INTERIOR & EXTERIOR REMODEL INCLUDING CARPENTRY, ELECTRIC, PLUMBING & FLOORS.	HI	M	Yes	Yes
1203527737000	COPELAND CONTRACTING COMPANY, INC	Tia Statam	UNIVERSAL CITY	tstatam@copeland-inc.com	210-225-4600	Commercial Plumbing, Commercial Electrical and General Commercial Construction	BL	F	No	Yes

1845469017700	CORPORATE CARE HOLDINGS, LLC	Susan Bono	HOUSTON	sbono@corporatecare.com	713-692-6300	We specialize in detailed cleaning including maintenance and restoration of fabrics, flooring and finishes. We are experts in emergency restoration cleaning and application of durable coatings.	WO	F	Yes	Yes
1474614863500	CORZA CONSTRUCTION LLC	Juan Carlos Garza	AUSTIN	juancarlos@corzaconstruction.com	830-703-6846	Construction General Contractor; project management, concrete, masonry, landscaping, carpentry, rest areas, site prep & removal	HI	M	No	Yes
1751991843100	COX CONCRETE CONTRACTORS, INC.	Brenda Jones	NACOGDOCHES	bjones@coxcontractors.com	936-564-6500	Concrete Construction, General Construction, Construction Management, Design-Build, Architecture, Interior Design.	WO	F	Yes	Yes
1752665791500	Carrco Painting Contractors, Inc	Yasmine Huerta	Dallas	jhuerta@carrcopainting.com	214-546-7606	Painting and Wall Covering Contractors	HI	M	No	Yes
1263197260600	Clearview Building Service & Restoration	Juana Gomez	San Antonio	juanygomez1125@gmail.com	210-421-7592	Construction management, single-family building, Construction management, residential remodeling, Addition, alteration and renovation, general contractors, commercial and institutional building, Construction management, commercial and institutional build	HI	F	Yes	Yes
1474390186100	Concrete Staining By Design	Herlinda Guerra	Austin	concretestainingbydesign@gmail.com	512-496-2428	To provide concrete staining and construction services.	HI	F	No	Yes
1205642752400	Corporate Building Services, Inc.	Sarah Boltz Byrne	Dallas	sboltz@ccleaning.com	972-506-7770	Corporate Building Services was established in 1954 in Chicago, and offered a new level of quality janitorial cleaning service. Because our excellent reputation grew and developed through the years, we expanded to Texas in 1982. We employ hundreds of ded	WO	F	Yes	Yes
1200265986500	Creed Construction, Inc.	Chester Reed	Mansfield	ruby@creedci.com	682-518-8835	Green builder and certified installer of AAC (Autoclaved Aerated Concrete). Capable of engineering and building from ground up. Total mason builder, brick, block, stone, stucco, concrete restoration, cleaning, caulking, dampproofing and repair.	BL	M	No	Yes
1853725748900	D & A COMPLETE SERVICES LLC	Dollie Adams	HOUSTON	dacompleteservices@gmail.com	832-655-3834	D&A is a small Full-Service General Contracting company that provides an array of home repairs, business repairs and renovations. We offer landscaping, Roof Repairs, Siding, professional sub-contractors and general contractors.	HI	F	Yes	Yes
1742523918700	D & S S CONSTRUCTION, INC.	Pres./JANNA SCHURY	CORPUS CHRISTI	janna@dssconstruction.com	361-992-3566	GENERAL CONTRACTOR.	WO	F	No	Yes
1203391431300	D.B.M. SERVICES, LP	President / Daniel Mendoza	MESQUITE	mherrera@dbmserviceslp.com	214-275-7930	Drywall, Ceilings, Paint, Patch and Paint, Wall Covering (Vinyl and Fabric), Texture	HI	M	No	Yes
1562589888500	DECENT CONSTRUCTION COMPANY, INC	SYED A HASHMI	PLANO	construction.decent@gmail.com	214-846-5113	General Contracting, Project Management, Site Work, Concrete, Masonry, MEP, Damp Proofing, Caulking, Sealing, Fire Safing and Selective Demolotion	AS	M	No	Yes
1824288646500	DMA CONTRACTORS INC.	Donna Allphin	PLANTERSVILLE	dallphin@sbcglobal.net	936-894-3533	Guardrail installation and repair, underground construction, directional boring, water well drilling, road and driveway building, backhoe and dozer work, mowing, all farm related construction, and concrete work, catering events	WO	F	No	Yes
1273104158300	DORAME GENERAL REPAIR AND LAWN, LLC	Ramon Dorame	CORPUS CHRISTI	do-ra-me@hotmail.com	361-533-6728	Full line of construction services including new construction & remodeling, i.e. drywall, painting, cabinetry, tile, framing, carpentry, siding, impact resistant or standard glass installation & concrete work. Electrical and Plumbing work through sub	HI	M	No	Yes

1300590854900	DRC CONSTRUCTION LLC	Owner/Dawn Cockerill	BEAUMONT	drc.construction@yahoo.com	409-223-1420	DRC Construction is a residential custom home builder with experience in apartments, condos, townhomes, storm restoration, and light commercial. We can fulfill all your needs at an affordable price and in a timely manner with no exception to quality.	WO	F	No	Yes
1201012492800	DURA PIER FACILITIES SERVICES, LTD	Owner - Tammi L Terry	HUMBLE	tammi@facilitiesources.com	713-337-5700	Commercal Renovations	WO	F	Yes	Yes
1824539422800	FAIRMONT PARKING LOT MAINTENANCE	Johnnie V Martinez	CORPUS CHRISTI	johnniemartinez259@gmail.com	361-944-4975	Building construction, new construction, fences, cement, carpentry, door/windows painting, portable building, floor, window, well site clean up pre/post.	HI	M	No	Yes
1751966126200	FALKENBERG CONSTRUCTION COMPANY, INC	John Castro	GRAND PRAIRIE	katy@falkenbergconstruction.com	214-324-4779	COMMERCIAL/INDUSTRIAL GENERAL CONTRACTOR.	HI	M	Yes	Yes
1465188739100	FEC CONSTRUCTION LLC	Erasmus Cantu	EAGLE PASS	erasmocantu6055@gmail.com	361-688-9773	FEC Construction LLC is a small family owned business which works with customers to provide service to construct residential and commercial projects as well as remodeling	HI	M	No	Yes
1271248885200	FELIX SALINAS GROUP, INC.	Felix Salinas	WATAUGA	fsalinas@excelcg.com	817-380-1500	Roofing, interior/exterior remodel, restoration, masonry, painting, drywall, commercial renovations, patios, outdoor kitchens.	HI	M	No	Yes
1922785859400	FITZ ASSOCIATES, LLC	Darla Lowden	HUMBLE	darla@fitzassoc.com	281-904-9280	Woman Owned, General Contractor, Engineering, Job Order Contracting, Design Build, ADA Compliance	WO	F	Yes	Yes
1752496796900	Facilities Consulting Group, Inc.	EDWIN MENDENHALL	DALLAS	ed.mendenhall@facilitiesconsulting.biz	469-628-6517	Janitorial Services	BL	M	No	Yes
1752205887800	G. L. MORRIS ENTERPRISES, INC.	Pres./Marla K. Murphy	CARROLLTON	marla@sun-belt.com	817-877-0866	Environmental Contractors, Excavation, Tank Removal, Drum Transportation, Soil Transportation & Disposal, Demolition, Hazardous Materials Handling, Treatment System Installation, Environmental and Geotechnical Drilling	WO	F	No	Yes
1752305253200	G.P. Waterproofing & Restoration	Luis Rosiles	Dallas	Irosiles@aol.com	972-642-4335	WATERPROOFING AND RESTORATION.	HI	M	No	Yes
1270296441700	G2 CONTRACTORS, LLC	Heather McGlasson	Mason	heather@g2contractors.com	817-739-6560	General Contractor / Certified Construction Manager (CCM) who primarily works with land management and historical government agencies in all Regions within the State of Texas. Performs any type and size of project in Texas.	WO	F	Yes	Yes
1834050961300	G2 Construction Services, Inc.	Jyl Gibson	Georgetown	jyl@g2csinc.com	512-688-5725	Commercial general contractor specializing in General Contracting, Design Build, Construction Management, Planning & Development, Pre-Construction Consulting. TIPS JOC awarded contractor.	WO	F	Yes	Yes
1208869458800	GARY MCGUIRE DEVELOPMENT INC	Gary McGuire	HOUSTON	gm@garymcguire51.com	713-539-2409	Concrete finishing, patching, grouting, concrete rebar, rod busting and form setting. Architectural patching and materials supply.	BL	M	Yes	Yes
1208450971500	GHR CONCRETE, INC.	Paul Gonzales	DALLAS	paul@ghrconcrete.com	214-325-7457	Full Service Paving Contractor, Offering Concrete Sawing, Removal and Replacement, Pourback	HI	M	Yes	Yes
1842521576300	GMR DRYWALL	MIRANDA CIRLOS	CORPUS CHRISTI	GMRCTX@GMAIL.COM	361-695-1803	Drywall	HI	F	No	Yes
1742713725600	GOETTING CONSTRUCTION COMPANY	Ed Kennedy	DALLAS	edheadk@sbcglobal.net	214-559-0862	GENERAL CONSTRUCTION, Commercial construction-specialty in interior finish-out, new structures, light comercial.	WO	F	Yes	Yes
1270105975500	GOLDEN CONCRETE L.L.C.	NORMA CANTU	SAN JUAN	CONCRETEGOLDEN@YAHOO.COM	956-781-4250	Concrete foundations.	HI	F	No	Yes
1742801036100	GOMEZ FLOOR COVERING, INC.	Robert Nocito	SAN ANTONIO	aescontrias@gomezfc.com	214-905-1901	Building remodeling and renovation; sales; flooring contractor	HI	F	Yes	Yes

1452149776900	GSI AMERICA INC.	Maria Florenica Schnicer	spring	info@gsi-america.com	832-948-4995	GSI America provides Janitorial, Cleaning and Sanitization Services including Night Cleaning, Day Maid, Day Porter, Carpet washing, Tile Wax, Strip and Scrub services.	HI	F	Yes	Yes
1453794796300	Galindo & Boyd Wall Systems, LLC	Manuel A Galindo	MESQUITE	mgalindo@galindoboyd.com	214-647-1528	Drywall and Insulation Contractors	HI	M	No	Yes
1711038225000	Globe Builders Inc.	Angelina Rodriguez Chavez	EL PASO	angierodriguez@globebuilders.com	915-533-8700	Building Construction, including General Contractors, and Operative Builders	HI	F	No	Yes
1260439585000	H3 CONSTRUCTION, LLC	Roxanne Hunt	ROANOKE	linda@h3-construction.com	940-295-4488	Concrete Work, Concrete Cutting/Coring, Wall Sawing, Electric Sawing, Flat Sawing, Selective Soft Demolition, Concrete Repair/Paving/Removal, Excavation, Hydro Excavation, Dirt Work, Ground Penetrating Radar, Roll Off Dumpster Rentals,	HI	M	No	Yes
1843981149000	HALLCON CONSTRUCTION, L.L.C.	Shayne Hall	AUSTIN	shayne@hallconconstruction.com	512-633-4980	Commercial Construction	WO	F	Yes	Yes
1464025568400	HAVOC SERVICES	JACOB URIAS	MIDLAND	urias_jacob80@yahoo.com	432-556-3221	General Contractor	HI	M	Yes	Yes
1412233395900	HEPCO DRYWALL & PAINTING CONTRACTORS INC	Nick Hernandez	HOUSTON	Nick@hepcodrywall.com	713-433-6135	Metal stud framing, drywall, texturing, painting, acoustical ceiling, insulation, interior light demolition,	HI	M	No	Yes
1261580419700	ICON DIVERSIFIED, LLC	Julie Ingram	WEATHERFORD	julie.ingram@icondiversified.com	817-913-2644	General Contractor, Construction Management, Risk Management, Quality Control, Field Supervision, Scheduling, Safety, Contract Management	WO	F	Yes	Yes
1742947118200	Ideal Finishes, Inc.	Deidre Morris	Rosenberg	deidre.morris@idealfinishes.com	713-988-8811	Painting & Wall Coverings Of Commercial Buildings	WO	F	No	Yes
1262544677300	Innovative Commercial Interiors, L.L.C.	Mary Cessna	Baytown	mcessna71@yahoo.com	832-572-7824	Remodel and lease space work, including: demolition, drywall, metal framing, acoustical ceilings, doors frames and hardware, and finishing	WO	F	No	Yes
1161664460200	Ivy Enterprise	Irene Villarreal	San Antonio	iv08lv@gmail.com	210-336-8035	Construction management, single-family building, Construction management, residential remodeling, Landscape Architectural Services, Administrative Management and General Management Consulting Services, Tree services (e.g., bracing, planting, pruning, rem	HI	F	No	Yes
1300410297900	J.R.O. Electrical Services L.L.C.	Joe R. Orcasitas	Adkins	orcasitas_j@yahoo.com	210-360-0377	Masonry Contractors; Electrical Contractors and Other Wiring Installation Contractors; Drywall installation; Painting (except roof) contractors	HI	M	No	Yes
1208904089800	JACKSON HILL INTEREST, LLC.	John Farrar	HOUSTON	John@fullmoonbuilders.com	713-504-4411	Super subcontractor, general contractor, project management, drywall, metal framing, paint, concrete foundations, paving retaining walls.	HI	M	No	Yes
1452991305600	JRJ ENTERPRISE LLC	OwnerDenise Anderson	AQUILLA	rdandersonus@windstream.net	254-694-3891	General contractor, subcontractor, custodial maintenance contractor	WO	F	Yes	Yes
1204721086400	Jeans Waterproofing Of Texas, L.P.	Lynda De Pippo	New Braunfels	info@jwtxas.com	830-557-4240	Painting, spraying, or coating, roof, Waterproofing contractors, All Other Specialty Trade Contractors.	WO	F	No	Yes
1760416259800	KA-TEX CONSTRUCTORS INC	RENE GRIFFITH	HOUSTON	rene@katexconstructors.com	713-692-0707	GENERAL CONTRACTOR. COMMERCIAL CONSTRUCTION/OFFICE BUILDOUT, ETC.	WO	F	No	Yes
1760369219900	KENNEDY CONTRACTING, INC.	Rebecca S. Kennedy	MAGNOLIA	rjskennedy@yahoo.com	281-356-8555	Commercial (non-residential) remodeling/ renovation/ building maintenance/ repair.	WO	F	No	Yes
1742479057800	Kegley, inc.	Anita Kegley	San Antonio	anitakegley44@gmail.com	210-857-4994	Construction Inspections, Client Representation on apartments, manufacturing buildings and commercial spaces. We represent our clients who need general contracting, project management, and design build construction.	WO	F	No	Yes
1264453891500	LARGIN CONSTRUCTION SERVICES, LLC	Jerry Jo Largin - President	CORPUS CHRISTI	jerryjo@larginconstruction.com	361-723-1573	General Contractor - Commercial construction	WO	F	Yes	Yes
1300837884900	LONE STAR TRS, LLC		CORPUS CHRISTI	lonestartsr@gmail.com	361-992-9448		HI	M	No	Yes

1863237234000	LONESTAR CONCRETE TECHNOLOGIES LLC	Garrett Williamson	KILGORE	garrett.williamson@lonestarconcrete.net	903-746-4771	Decorative concrete overlay/stamping, concrete resurfacing and sealing, decorative epoxy flooring, industrial/commercial epoxy flooring, concrete staining, concrete crack repair	WO	F	No	Yes
1992206113000	LOVES GENERAL MANAGEMENT SERVICES LLC	Jesse Love	FORT WORTH	Jesse@lovesmanagement.com	336-669-3661	General contractor, Roofing Contractor, Remediation Contractor, concrete Contractor, Asphalt Contractor, Epoxy contractor,	DV	M	Yes	Yes
1820775416100	LOYOLA CONSTRUCTION, LLC	Jessica Loyola	NEW BRAUNFELS	loyolaconstructionllc@gmail.com	830-743-5336	We offer all concrete related jobs weather it be New foundations, sidewalks, curbs , parking lots. We also do repairs to buildings like roof repairs, floors, walls etc.	HI	F	No	Yes
1752355275400	LUBBOCK MASONRY, INC.	SHERI SISSON	LUBBOCK	dandlmasonry@yahoo.com	806-795-2954	Commercial Masonry construction- new & existing.	WO	F	No	Yes
1113686628900	Longoria Masonry	JESUS LONGORIA	Lockhart	longoriamasonryinc@gmail.com	512-398-3188	MASONRY & Stucco sub-contracting CONSTRUCTION.	HI	M	No	Yes
1473382694600	Lozcon Masonry Company, LLC	Carlos Lozano	McAllen	carlos@lozconmasonry.com	956-458-0813		HI	M	No	Yes
1815103763900	MAKENOSH CONCRETE & CONSTRUCTION, LLC	Kenneth Harmon	LUMBERTON	kennethh@makenosh.com	409-434-0675	Set up forms, pour out concrete, and finish concrete. Concrete labor.	BL	F	No	Yes
1841978311500	MARQUEE PROPERTY SERVICES LLC	Brittany Brown	CYPRESS	accounting@marqueepropertyservicesllc.com	832-372-9304	Construction Management/Maintenance, General Construction, Powerwashing, Striping, Concrete	BL	M	No	Yes
1825053318100	MARRS PATRIOT CONSTRUCTION, LLC	Lance B Marrs	WICHITA FALLS	marrspatriotconstruction@gmail.com	940-500-5718	Residential and commercial remodeling	DV	M	Yes	Yes
1263930450500	MEDEL PAINTING, INC.	Rafael Medel	BUDA	rmedel@medelpaintinginc.com	512-312-4508	Commercial Painting Contractor. We tape, float, paint, and install wallcovering. We do interior and exterior projects.	HI	M	Yes	Yes
1861934354600	MID-TEX CONTRACTING LLC	BRENNA SIMS	WHITNEY	brenna@mid-texcon.com	254-495-5665	General constructions services including MEP.	WO	F	No	Yes
1821212282600	MIGHTY SERVICES CONSTRUCTION, LLC	Monica Atterberry	DALLAS	monica@mightysconstruction.com	469-471-4519	Mighty Service Construction, LLC provides Construction, General Contracting Subcontracting Services in various areas of construction. HVAC, electrical, life saving systems,etc	BL	F	No	Yes
1813186284100	MIKOCORP, LLC	Pres./Matthew Lindsey	WEATHERFORD	matt@mikocorp.com	817-458-4425	Carpentry/framing metal & wood, electrical, painting, suspended acoustical ceilings, demolition services, maintenance and repair of existing buildings and new building construction.	AI	M	Yes	Yes
1760586361600	MILLENNIUM PROJECT SOLUTIONS, INC.	Vice President/Luke Morgan	CROSBY	mmorgan@mps-team.com	281-328-2200	Building construction, infection/dust control, asbestos abatement, mold remediation in the commercial, healthcare and educational facilities.	WO	F	No	Yes
1742890583400	MLP Ventures Inc.	Liborio Perez	Von Ormy	mip@att.net	210-623-8172	General Contractors specializing in remodeling and new construction. Scope of work includes any and all phases of construction including design/build, project management, quality control, and specific trade construction (arch, mech, elect work).	HI	M	Yes	Yes
1470957150000	Madero Engineers & Architects, LLC	Frank Madero	Houston	frank@madero.net	281-610-0367	Engineering Consulting; Program/Project/ Construction Mgmt; Rehab & Improvement of Infrastructures/Engineering Services, General Management Consulting Services & Project Management/Repair of Metal and Concrete Structures/Coating/ FRP Design Calculations	HI	M	No	Yes

1751431896700	Mobile Enterprises, Inc.	John Pierce	Fort Worth	Lpierce@mei.global	817-921-1444	49 Year Old Specialty Commercial Construction Company specializing in: Epoxy/Urethane Injection, Composite Strengthening, Joint Sealants, Expansion Joint Assemblies, Waterproofing, Architectural & Structural Restoration, Polymer Floors;(TX, LA, AR, OK)	WO	F	Yes	Yes
1461758020500	NERIE CONSTRUCTION LIMITED LIABILITY COM	Joseph Nerie	Houston	Joe@nerieconst.com	281-996-5551	Service Repair, Concrete/Asphalt Services	HI	M	No	Yes
1205826125100	NETI CONSTRUCTION ENTERPRISES, LLC	Pres./Subbu Neti	SUGAR LAND	subbu@theconstrcorp.com	832-237-5588	General Contractor involved in building (ground-up & Build-out) of office, medical, educational & retail facilities.	AS	M	No	Yes
1473035911500	NOBLE TEXAS BUILDERS, LLC	Christine Blouch	La Feria	juan.delgado@nobletx.net	956-520-8183	General Contractor, Construction Manager, Design Build, Building Maintenance	HI	M	No	Yes
1202089172200	NORTH AMERICAN COMMERCIAL	Partner / Lynn Dunlap	DALLAS	lynn@naccolp.com	972-620-9975	General contracting specializing in interior finishout and all related trades	WO	F	No	Yes
1384116297000	NORTHERN LIGHTS GROUP LLC	Rhone Raymond	AUSTIN	rraymond@spauldingdecon.com	512-651-1067	Bio hazard, viral disinfection, trauma scene, mold, water, fire hoarding and crime scene clean up and remediation services. We also offer construction and build back including demolition, paint, drywall and flooring installation.	WO	F	Yes	Yes
1841931681700	NORTHSTAR SOLUTIONS LLC	TONY BEAMON	THE COLONY	tony@northstarfsi.com	972-333-6502	We are a complete janitorial service provider and landscape maintenance	BL	M	Yes	Yes
1262453708500	New Community Construction LLC	Marlon Barabin	Houston	mbara48792@aol.com	281-608-2420	Residential - general contracting - framing, roofing, cornice, plumbing, electrical, leading, concrete, fencing, flooring, renovation.	BL	M	No	Yes
1851098045300	OLARICHE' CONSTRUCTION SERVICES LLC	Chiaka Ogechi Akarichi	RICHARDSON	ocs@contractor.net	914-255-2654	Concrete flatwork, foundation, Plumbing and HVAC system installations and maintenance. We also offer Project management and construction management services.	BL	F	Yes	Yes
1760018324200	PAYLESS INSULATION, INC.	VP/ELISA DIAS	HOUSTON	lmk@paylessinsulation.com	713-868-1021	INSTALLATION OF INSULATION, FIREPROOFING & ACOUSTICAL-DISTRIBUTORS OF COTTON INSULATION & DUCTS	WO	F	No	Yes
1331135164000	PIATRA INC.	Mirela Glass	Austin	mglass@piatrainc.com	512-299-0404	Company offering general construction services with a focus on concrete, masonry, welding and structural metal structures and fencing projects.	WO	F	No	Yes
1760660283100	PILGRIM CONTRACTORS, INC.	Pres./Elise Carranza	PINEHURST	elise.carranza@pilgrimcontractorsinc.com	281-356-7647	Commercial and Residential construction.	HI	F	No	Yes
1872456613000	PINION 91 CONTRACTING, LLC	John Gusti	ROANOKE	pinioncontracting@gmail.com	817-600-8069	General Contractor, construction, construction management, remodel, roofing, restoration, painting, drywall, framing, mold remediation, concrete, multiple division contractor	WO	F	Yes	Yes
1271892553500	PLAN B DSGN, LLC	Raul Wong	GRAND PRAIRIE	raul@planbdsgn.com	972-572-2527	Commercial Interiors, Interior Finish-Out, Cleanrooms/Data Centers, Ceiling Systems, Wall Systems, HEPA Filters, Residential Remodel, Renovation, CAD, Environmental Design, BIM Drafting.	HI	M	No	Yes
1743017107800	PMG CUSTOM HOMES, INC.	Phillip Garcia	COLUMBUS	pgarcia@five-oak.com	979-732-5001	General contractor that also subcontracts interior finishings of flooring, cabinets, countertops, hardware, etc.	HI	M	No	Yes
1760405744200	PRIMIS CORPORATION	Louis Carranza	HOUSTON	primiscorp@peoplepc.com	713-906-7466	WOODEN PALLET/LUMBER SUPPLIER/EXCAVATION WORK/CONCRETE, DRYWALL AND INSULATION, PAINTING AND DRYWALL COVERINGS, FLOORING CONTRACTOR, TILE, CABINETS, CA	HI	M	No	Yes
1822675567800	Pena Custom Masonry		Orange Grove	penacustommasonry@yahoo.com	361-510-7044		HI	M	No	Yes

1352614736100	Post Oak Construction, LLC	Christopher Esparza	Santa Fe	esparza716@gmail.com	281-501-0332	Painting, Flooring, Drywall, Framing, Demolition, Concrete Sidewalk, Pressure Washing, Cabinetry, ADA Ramps, & Carport	HI	M	No	Yes
1203109350800	Prestique, Inc.	Lisa Cunningham	Dayton	lisa@rangerroof.com	281-328-3678	General Construction for commercial, industrial and residential customers	WO	F	No	Yes
1271459490500	Proficient Constructors, LLC	Iris Luna	San Antonio	proficientconstructors@gmail.com	210-764-9095	We are a full service commercial general contractor that self performs masonry and concrete.	HI	F	No	Yes
1742462996600	Pronto Sandblasting & Coating Inc.	George Garcia	San Antonio	pronto_accounting@satx.rr.com	210-633-2030	Concrete paving (i.e., highway, road, street, public sidewalk), Curbs and street gutters, highway, road and street, construction.	HI	M	No	Yes
1020555210100	Q. A. Construction Services, Inc.	LILY GUTIERREZ	Austin	lily@qacsi.com	512-637-6120	Full service general contracting construction services.	HI	M	Yes	Yes
1863387196900	QLTY CONCRETE LLC		Amarillo	perlayosoy1@yahoo.com	806-236-6477		HI	F	No	Yes
1020720408100	QUALITY INNOVATIONS, INC.	President / Michele L. Morgan	BOERNE	Michele@QI2LLC.com	281-705-8709	GENERAL CONTRACTOR AND MATERIAL SUPPLIER FOR CONSTRUCTION PROJECTS	WO	F	No	Yes
1461207653000	R G RENOVATIONS & CONSTRUCTION LLC	Rodolfo G Gonzalez	LAREDO	rgrenovations100@gmail.com	956-795-0028	Paint,carpentry,dry wall,electrical,repairs,trimming, mill work and any repairs or add ons for residential and commercial buildings.	HI	M	Yes	Yes
1931359448300	RED CREEK, LLC	John Aviles	UVALDE	contact@redcreekco.com	830-275-2727	General Freight Transportation, General Consulting, General Contracting, General Services	HI	M	Yes	Yes
1803164114700	REID'S ESTIMATING AND CONTRACTING LLC	Reid's Estimating and Contracting LLC	SUGAR LAND	breid@reidsestimatingllc.com	303-261-2089	Reid's Estimating and Contracting performs and bids on: Waterproofing applications to commercial and residential builds, Remote Project management services, and single family home construction	BL	M	No	Yes
1201229286300	RESTORATION SPECIALISTS LLC	Sheri DeMattia	DALLAS	sheri.demattia@rs1967.com	972-342-5584	Emergency Service and Commercial Construction	WO	F	Yes	Yes
1453832678700	REYES-TAYLOR CONSTRUCTION LLC	Carissa Reyes	HOUSTON	reyestaylorconstruction@gmail.com	281-300-6919	General Contractor, Interior Build out (Paint, floor, Sheetrock, MEP, Elevator)	BL	F	No	Yes
1752643958700	RICHARDSON AND SON ROOFING AND	President / Reginald Richardson	ROWLETT	reggie@richardsonandsonconstruction.com	972-780-3720	GENERAL REMODELING AND CONSTRUCTION: CONCRETE, ASPHALT, PAINTING, MASONRY, ROOFING, SIDING, WINDOWS. Residential/commercial roofing, roofing repairs, exterior/interior painting, seamless gutters.	BL	M	No	Yes
1814439770200	RIGHT CHOICE DEVELOPMENT AND CONSTRUCTIO	Danielle Wright	KATY	danielle@rightchoicedev.com	832-567-9648	Right Choice Development & Construction is a female-owned, Houston based commercial general contractor that specializes in corporate interior and exterior remodels and build-outs, retail spaces, shopping centers, industrial spaces and office buildings.	WO	F	Yes	Yes
1752491456500	ROC Construction, Inc.	Romeo Collazo	DALLAS	romeo@rocdallas.com	214-349-1704	Masonry and Stone Sub-Contractors	HI	M	Yes	Yes
1921474268600	ROVICON CONTRACTING SERVICES LLC	Victor Davies	HOUSTON	vdavies@roviconenergys.com	832-407-5522	Residential Construction Management	BL	M	Yes	Yes
1465218100000	RUCOBA & MAYA CONSTRUCTION, LLC	Rodolfo Rucoba	KYLE	florencio@rmconstructiongroup.com	832-867-6673	Special Trade Construction	HI	M	No	Yes
1751835481000	RUDD-PALMER CO., INC.	Victor Aranda	AMARILLO	jerry@ruddpalmer.com	806-374-8581	Joint sealants, waterproofing, concrete structural repair, firestopping, deck coatings, joint stabilization, bridge joints, consulting.	HI	M	No	Yes
1743061738500	RYCON E&C, LLC	Rey C Ybarra, P.E.	KINGSVILLE	ryconec@gmail.com	361-455-7651	General Contractor: Areas of expertise include Design & Build Projects (Registered Professional Engineer),Commercial Building Construction including Labs, Underground Utilities (water, sewer, gas, lift stations, etc), Plumbing, Electrical,& Foundations.	HI	M	No	Yes
1834189431100	RYMARH CORPORATION	Maria Hobbs	LEANDER	rymarhcorporation@gmail.com	512-986-9625	Construction General Contractor Construction Management	HI	F	Yes	Yes

1870887959000	Reign Construction	John Cruz	San Antonio	Reign.Construction@outlook.com	210-672-9683	Renovations, Rehabs, interior Finishes, Exterior Finishes, Concrete and Masonry construction, Asphalt and road pavement, striping and road markings, ADA construction, Plumbing, HVAC, Electrical, Demolition	HI	M	No	Yes
1831424454400	S-CON CONSTRUCTION, LLC	Ashley Villalobos	CORPUS CHRISTI	ashley@s-conconstruction.com	361-299-5161	General Construction, site work, trenching, building renovations.	HI	M	No	Yes
1815055958300	S.KELLY HOME RENOVATIONS, LLC	Alex Siminski	AUSTIN	diana@skellyhome.com	512-971-1188	Skelly Home is a full service residential and commercial renovation firm. We are the general contractors on commercial / residential / industrial projects throughout the Austin area.	WO	F	No	Yes
1812000678000	SHARK BRITE LLC	Claudia Ferguson	ARLINGTON	Sharkbritellc@gmail.com	817-941-4412	We are a commercial cleaning company and building maintenance. We offer construction, tile and grout cleaning, construction cleaning. We clean office, provide window and carpet cleaning. We provide quality customer service.	BL	F	No	Yes
1850910549200	SHIELDER VENTURES, LLC DBA D&G QUALITY	Vice President - Mike Kowalski	BURLESON	mike@dgroofing.com	713-724-2480	Light Construction, Roofing and Waterproofing. Metal Canopy, Truss Screens, & Wind Screens.	WO	F	No	Yes
1881014561700	SKO Elite Repair LLC	Aldo Davila	San Juan	hector@skoelite.org	956-739-0810	General Contracting, Building Construction & Facility Maintenance	HI	M	Yes	Yes
1203194307400	SMB GROUP LLC	Burhan Ali	CYPRESS	burhan@smbgroup.net	281-272-0786	We are a Design Build Company. Services include Architectural and Structural Drawings, Permits, Full ground up construction and Interior Build outs. We also have a Design showroom for flooring, cabinets, countertops, lighting, plumbing and windows.	AS	M	Yes	Yes
1825489573500	STERLING FACILITY SOLUTIONS, LLC	Juan G Romero	Corpus Christi	sterlingfacilitiesolutions3@gmail.com	361-425-5498	Full Service Facilities Maintenance provider offering on-going maintenance and repair of equipment (i.e....HVAC, electrical and plumbing). Construction services include renovation, painting, roofing, siding and fencing. Ground maintenance and locksmith	HI	M	No	Yes
1800675903100	STIFFS 5 STAR ENERGY CONSERVATION SERVIC	MICHAEL STIFF	ARLINGTON	mrstiff1_mikestiff@yahoo.com	817-223-0909	General Contractor	BL	M	No	Yes
1412095040800	STRAIGHT LINE SAWING & SEALING, INC.	Eric Johnson	GRAND PRAIRIE	ejohnson@silstexas.com	972-590-8922	pavement sawing and sealing, concrete construction, concrete repairs and maintenance	BL	M	No	Yes
1760700482100	STRUCTURAL CONCRETE SYSTEMS, LLC	Michele DiBassie	HOUSTON	scs-michele@swbell.net	281-583-7776	Concrete Structural Repair	WO	F	No	Yes
1452850105000	SYNERGY PROJECT CONTRACTORS, INC.	Luis Luna	EL PASO	LLUNA@SPC-PM.COM	915-487-4347	Heavy Highway Construction and Maintenance, General Contractors; IT Infrastructure/Cabling; Physical Security Systems (CCTV/Access Control) TX License B17681	HI	M	Yes	Yes
1260331391200	Seneca Construction Management, LLC	GWENDOLYN MAUPIN	KILLEEN	gmaupin@seneca-construction.com	254-394-9303	I am a women owned and operated business. In June of this year I have successfully operated this construction company. I'm very proud of what I have built. It has not been easy to run a women ran company in this man dominated industry. I also have mostly	AI	F	No	Yes
1752786301700	Sigma Polishing & Restoration, LP	Karen Kanaan	Dallas	kkanaan@sigmapolishing.com	214-631-5500	Natural stone, tile, Terrazzo and concrete contractors: Refinishing, restoring, polishing, care and maintenance of terrazzo, marble, granite, travertine, limestone, porcelain and concrete. Clean, re-grout and repair tile. Repair and patch terrazzo, natur	WO	F	Yes	Yes

1820841062300	Sir Charles Investments Inc.	Brittney Charles	Spring	sircharlesinv@gmail.com	832-992-9012	Real Estate Agent, Property Management, Residential Remodelers, Janitorial Services, and Construction Management	BL	F	No	Yes
1760392985600	Smith - Mobley, Inc.	Lavon Smith	Houston	info@smithmobleyinc.com	713-831-6817	Carpentry, Concrete Work, Construction Management And Underground Utilities; Stadium & Auditorium Seat Installation, And Demolition Work; Stadium & Auditorium Seat Installation Debris Removal and Demolition Work	BL	M	No	Yes
1813845935100	Stiles General Contractors LLC	Adeliz Stiles	El Paso	stilescontractors@gmail.com	915-320-3399	Grounds Maintenance, Maintenance and Construction, Mowing, Trimming, Edging, Tree Removal, Pesticide/Herbicide application, Construction, Painting, Electrical, Plumbing, Roofing, Flooring, Demolition, Debris Removal, Maintenance, Janitorial Services.	HI	F	No	Yes
1760393668700	TEXAS LIQUA TECH SERVICES, INC.	Charles Small	HOUSTON	charles@liquatech.com	713-225-5325	Waterproofing, Roofing & Sheetmetal(caulking,glazing, repellents, deck coatings,elastomeric coatings,concrete & masonry repair, leak repairs, pressure washing, reroofs, roof repairs, roof coatings	WO	F	Yes	Yes
1271634122200	THE BUTLER ENTERPRISES	Cass Butler	RED OAK	cass@TheButlerEnterprises.com	469-554-9654	The Butler Enterprises is an African American Woman Owned Business consisting of Event Planning, Government Contracts and Procurement, Project Management, Social Media Marketing & Development, Recruiting & Staffing, and E-Commerce Businesses.	BL	F	Yes	Yes
1743210863100	TMG CONTRACTING, LLC	Owner Tony Gutierrez	HUTTO	tmgcontracting.info@gmail.com	512-801-2595	General construction services, concrete, fencing, finish out, flooring, framing, drywall, painting and all types of roofing, welding, power washing, paving, demolition, re-model, build out, striping	HI	M	No	Yes
1841956886200	TONY PUGA CONSTRUCTION LLC	Tony Puga	SAN ANTONIO	Office@tcp-tx.com	210-475-1902	Addition, alteration and renovation, residential building, general contractors, Painting and Wall Covering Contractors, Flooring Contractors and Door and window, prefabricated, installation.	HI	M	No	Yes
1611624827500	TP&R CONSTRUCTION, LLC	Nephtali Lucero	DESOTO	info@tpr-construction.com	972-814-3697	DRYWALL,FRAMING, ACOUSTIC CEILING,PAINTING,FLOORING,TEXTURES, ROOFING, NEW CONSTRUCTION, DEMO	HI	M	Yes	Yes
1760775331000	TRINI CONSTRUCTION BUILDER LLC	Reginald Worlds	AUSTIN	INFO@TRINICONSTRUCTIONBUILDER.COM	512-506-1310	Subcontracting & General Construction opportunities	BL	M	No	Yes
1273712941600	Texas Velocity Enterprises LLC	Darren Richardson	San Antonio	drichardson@poweredbyvelocity.com	210-251-3466	General contractor. Construction projects to include roofing, roads and interior/exterior work.	DV	M	No	Yes
1270962229900	VCI BUILDERS, INC.	Jose Luis Arredondo, Jr	MISSION	joe@vcibuilders.com	956-627-3101	General contractor with experience in break ground, excavation, foundation, utilities, framing, roofing, electrical, insulation, drywall, flooring/tile, painting, cabinetry, finish outs,repair/remodeling work to existing structures.	HI	M	No	Yes
1760541820500	W. A. Robbins Construction Co., Inc.	Wendell A. Robbins III	Houston	wendell3@warobbinsconstruction.com	713-644-5823	Interior & Exterior Renovations, Concrete Construction, and Underground Utilities (cabling & fiber optics)	BL	M	No	Yes
1825329568900	W. Houston Restoration	WAYNE HOUSTON	WAXAHACHIE	wayne@whoustonrestoration.com	844-662-3478		BL	M	No	Yes
1743139271500	WEATHERPROOFING SERVICES LLC	Dianne Whitfield	CROSS ROADS	dianne@wstexas.com	972-731-8222	Commercial, Industrial and Governmental Roofing, Gutters & Downspout Maintenance and Repair Services; Weather and Waterproofing Maintenance & Repair Services; Metal Roof Specialist; Thru-Wall Flashing Specialist; Concrete Patching and Specialty Coating	WO	F	Yes	Yes
1752659366400	WHITE CONSTRUCTION COMPANY	President, Glinn H. White, Jr.	KERRVILLE	glinn@whiteconstructioncompany.com	830-257-7477	General Contractor serving the Texas Hill Country.	AI	M	Yes	Yes

1263917760400	WILSON BUILDING SERVICES, INC.	Wendell A. Wilson	STAFFORD	info@wilsonbuildingservice.com	281-780-0700	Construction maintenance for the private and public sector. Provide support medium-sized commercial building, municipal, transportation infrastructure, industrial building projects and maintenance services for master planned communities.	BL	M	Yes	Yes
1455404258100	WITHERSPOON CONSTRUCTION, LLC	Ray L Witherspoon	ODEM	witherspoonconstructionllc@gmail.com	361-533-6651	Framing, siding, painting, drywall installation, tape, float and texture, finish carpentry/cabinetry and trim, epoxy to tile flooring, room additions, and fences, porches and decks.	WO	F	Yes	Yes
1823904941600	West Texas Mowing LLC	Rocio Ramos	Plainview	rocio_ramos12@hotmail.com	806-729-3164	Mowing Service.	HI	F	No	Yes
1454044771200	YUCCA CONTRACTING	Maggie Vaquera	EL PASO	israel@yuccaconstruction.com	915-525-7135	Painting, insulation, plumbing, electrical, demolitions, flooring, roofing, suspending ceilings, door/window frames all types,concrete slabs, sidewalks,footings asphalt excavation, field and shop welding, field and shop steel fabrication	HI	M	Yes	Yes
1742991135100	Z & L CONCRETE CONTRACTORS, INC.	George Zurita	SAN ANTONIO	zlconcrete@yahoo.com	210-825-1548	Concrete Contractor	HI	M	No	Yes
1831791482000	ZAMCO DIRECTIONAL DRILLING LLC	Josue zamarron Josue zamarron	HOUSTON	josue@zam-construction.com	832-306-0400	Underground utilities Storm Sewer Duct bank	HI	M	No	Yes

Date : 2024/01/18 09:19:13

CMBL SUMMARY

Search Found 177 Vendors ,177 are Hubs , Includes 0 Inactive Vendors

Search Condition : SearchType=HUB's Only,Section1 Class Code=910,Section1 Item(s)=(51)

Results for HUBs for 910-71 : Shoring and Reinforcement Services

Vendor ID	Company Name	Contact Person	City	Email	Phone	Business Description	HUB Eligibility	HUB Gender	CMBL Stat	HUB Status
1475357271900	1DZ ENTERPRISE LLC	Debra A. Garcia	ARANSAS PASS	debbiegarc20@gmail.com	361-534-4244	Janitorial Service, Construction Cleanup, Site Preparation, Demolition, Demolition Cleanup,Paving, General Construction, Concrete Work	HI	F	No	Yes
1461995281600	360 TXC, LLC	Tony LESTER	AUSTIN	dlester@360txc.com	512-229-6440	We provide general contracting and complete project planning and management services. Our vast project portfolio covers everything from 1,000sqft interiors and renovations to 25,000sqft+ ground-up and core-shell buildouts.	BL	F	No	Yes
1752966405800	ACUMEN ENTERPRISES, INC.	Wayne Boyter	DESOTO	wayne@acumen-enterprises.com	972-572-0701	Mechanical HVAC & plumbing contractor, mechanical insulation, & general construction	AI	M	Yes	Yes
1200334965600	ALAMO ENVIRONMENTAL, INC. DBA ALAMO 1	President / J. Alex Salas	SAN ANTONIO	jsoto@alamo1.com	210-404-1220	Full service contractor providing general construction, special trade construction, demolition, remediation, abatement, hazardous material disposal, emergency response HI services, spill response services, and commercial waste services.	HI	M	Yes	Yes
1841904274400	AMERICAN TRU SOURCE LLC	Jose Salinas	FRIENDSWOOD	americantrusource@gmail.com	713-430-6217	American Tru Source LLC specialize in excavation and turning directional boring for public utilities and general construction.	HI	M	No	Yes
1760110237300	AQUATEX WATER CONDITIONING, INC.	NANCY STANDEFORD	ALVIN	nls@aquatexwater.com	281-331-7777	water softening, filtration and purification, sales and service.	WO	F	No	Yes
1742939960700	BORDER DEMOLITION & ENVIRONMENTAL INC	BONNIE SOLIS	EL PASO	bonniesol@borderdemo-enviro.com	915-860-8855	Demolition and Asbestos, Lead and Mold Abatement Contractor.	HI	F	Yes	Yes
1752918306700	CARCON INDUSTRIES & CONSTRUCTION, LLC	Arcilia Acosta	DALLAS	aacosta@carconindustries.com	214-352-8515	GENERAL CONSTRUCTION SERVICES-CONSTRUCTION PRODUCTS PURCHASING- TELECOMMUNICATIONS SERVICES	HI	F	No	Yes
1473191874500	CBMAA, Inc.	Christopher Patton	Forney	chris.patton@wellingtonfs.com	972-853-1455	General Contracting to include Project Management	BL	M	No	Yes
1830851049600	CDM7, LLC	Trey Harris	Spring	trey@cdmseven.com	713-253-2322	Construction Management, Project/Program Management	BL	M	No	Yes
1822756317000	COASTAL BEND ROOFING, LLC.	Matt Jensen	PEARLAND	info@cbrcs.com	281-407-0023	CBRCs is experienced in small and large scale renovations, additions, new construction, and demolition in both the public and private sectors. We provide disaster relief to include complete restoration, roofing, and property recovery.	WO	F	Yes	Yes
1742523918700	D & S S CONSTRUCTION, INC.	Pres./JANNA SCHURY	CORPUS CHRISTI	janna@dssconstruction.com	361-992-3566	GENERAL CONTRACTOR.	WO	F	No	Yes
1562589888500	DECENT CONSTRUCTION COMPANY, INC	SYED A HASHMI	PLANO	construction.decent@gmail.com	214-846-5113	General Contracting, Project Management, Site Work, Concrete, Masonry, MEP, Damp Proofing, Caulking, Sealing, Fire Safing and Selective Demolition	AS	M	No	Yes
1273104158300	DORAME GENERAL REPAIR AND LAWN, LLC	Ramon Dorame	CORPUS CHRISTI	do-ra-me@hotmail.com	361-533-6728	Full line of construction services including new construction & remodeling, i.e. drywall, painting, cabinetry, tile, framing, carpentry, siding, impact resistant or standard glass installation & concrete work. Electrical and Plumbing work through sub	HI	M	No	Yes
1201012492800	DURA PIER FACILITIES SERVICES, LTD	Owner - Tammi L Terry	HUMBLE	tammi@facilitiesources.com	713-337-5700	Commerical Renovations	WO	F	Yes	Yes
1752305253200	G.P. Waterproofing & Restoration	Luis Rosiles	Dallas	lrosiles@aol.com	972-642-4335	WATERPROOFING AND RESTORATION.	HI	M	No	Yes
1270296441700	G2 CONTRACTORS, LLC	Heather McGlasson	Mason	heather@g2contractors.com	817-739-6560	General Contractor / Certified Construction Manager (CCM) who primarily works with land management and historical government agencies in all Regions within the State of Texas. Performs any type and size of project in Texas.	WO	F	Yes	Yes
1742138792300	GAINCO, INC.	Theresa Nix	PORTLAND	t.nix@gaincoinc.com	361-643-4378	Full service environmental remediation company providing environmental drilling, waste management, remediation and remediation systems, tank cleaning, demolition, UST removal and emergency response	WO	F	Yes	Yes
1464025568400	HAVOC SERVICES	JACOB URIAS	MIDLAND	urias_jacob80@yahoo.com	432-556-3221	General Contractor	HI	M	Yes	Yes
1812290651600	Ibarra Underground, LLC	Juan Ibarra	Rockwall	ibarraunderground.juan@gmail.com	214-864-0383		HI	M	No	Yes
1760416259800	KA-TEX CONSTRUCTORS INC	RENE GRIFFITH	HOUSTON	rene@katexconstructors.com	713-692-0707	GENERAL CONTRACTOR. COMMERCIAL CONSTRUCTION/OFFICE BUILDOUT, ETC.	WO	F	No	Yes
1264453891500	LARGIN CONSTRUCTION SERVICES, LLC	Jerry Jo Largin - President	CORPUS CHRISTI	jerryjo@larginconstruction.com	361-723-1573	General Contractor - Commercial construction	WO	F	Yes	Yes
1742490361900	MALTBY BUILDERS, INC.	SANDRA MALTBY	KINGSVILLE	maltbybuilders@sbcglobal.net	361-592-8426	COMMERCIAL & RESIDENTIAL-NEW & REMODELING	WO	F	No	Yes
1861934354600	MID-TEX CONTRACTING LLC	BRENNA SIMS	WHITNEY	brenna@mid-texcon.com	254-495-5665	General constructions services including MEP.	WO	F	No	Yes
1742890583400	MLP Ventures Inc.	Liborio Perez	Von Ormy	mlp@att.net	210-623-8172	General Contractors specializing in remodeling and new construction. Scope of work includes any and all phases of construction including design/build, project management, quality control, and specific trade construction (arch, mech, elect work).	HI	M	Yes	Yes
1751431896700	Mobile Enterprises, Inc.	John Pierce	Fort Worth	lpierce@mei.global	817-921-1444	49 Year Old Specialty Commercial Construction Company specializing in: Epoxy/Urethane Injection, Composite Strengthening, Joint Sealants, Expansion Joint Assemblies, Waterproofing, Architectural & Structural Restoration, Polymer Floors;(TX, LA, AR, OK)	WO	F	Yes	Yes
1760018324200	PAYLESS INSULATION, INC.	VP/ELISA DIAS	HOUSTON	lmk@paylessinsulation.com	713-868-1021	INSTALLATION OF INSULATION, FIREPROOFING & ACOUSTICAL-DISTRIBUTORS OF COTTON INSULATION & DUCTS	WO	F	No	Yes
1760660283100	PILGRIM CONTRACTORS, INC.	Pres./Elise Carranza	PINEHURST	elise.carranza@pilgrimcontractorsinc.com	281-356-7647	Commercial and Residential construction.	HI	F	No	Yes
1833198919600	PRICKLY PEAR CONTRACTING LLC	Benjamin Rodriguez	CANYON	pricklypearcontracting@gmail.com	443-721-4980	We provide any construction type services. We Excell in areas that are specialty repairs installs or maintenance.	HI	M	Yes	Yes
1814439770200	RIGHT CHOICE DEVELOPMENT AND CONSTRUCTIO	Danielle Wright	KATY	danielle@rightchoicedev.com	832-567-9648	Right Choice Development & Construction is a female-owned, Houston based commercial general contractor that specializes in corporate interior and exterior remodels and build-outs, retail spaces, shopping centers, industrial spaces and office buildings.	WO	F	Yes	Yes
1881014561700	SKO Elite Repair LLC	Aldo Davila	San Juan	hector@skoelite.org	956-739-0810	General Contracting, Building Construction & Facility Maintenance	HI	M	Yes	Yes

1760700482100	STRUCTURAL CONCRETE SYSTEMS, LLC	Michele DiBassie	HOUSTON	scs-michele@swbell.net	281-583-7776	Concrete Structural Repair	WO	F	No	Yes
1760392985600	Smith - Mobley, Inc.	Lavon Smith	Houston	info@smithmobleyinc.com	713-831-6817	Carpentry, Concrete Work, Construction Management And Underground Utilities; Stadium & Auditorium Seat Installation, And Demolition Work; Stadium & Auditorium Seat installation Debris Removal and Demolition Work	BL	M	No	Yes
1271634122200	THE BUTLER ENTERPRISES	Cass Butler	RED OAK	cass@TheButlerEnterprises.com	469-554-9654	The Butler Enterprises is an African American Woman Owned Business consisting of Event Planning, Government Contracts and Procurement, Project Management, Social Media Marketing & Development, Recruiting & Staffing, and E-Commerce Businesses.	BL	F	Yes	Yes
1760541820500	W. A. Robbins Construction Co., Inc.	Wendell A. Robbins III	Houston	wendell3@warobbinsconstruction.com	713-644-5823	Interior & Exterior Renovations, Concrete Construction, and Underground Utilities (cabling & fiber optics)	BL	M	No	Yes

Date : 2024/01/18 09:23:11

CMBL SUMMARY

Search Found 35 Vendors ,35 are Hubs , Includes 0 Inactive Vendors

Search Condition : SearchType=HUB's Only,Section1 Class Code=910,Section1 Item(s)=(71)

Results for HUBs for 912-23 : Construction, General: Backfill Services, Digging, Ditching, Road Grading, Rock Stabilization, etc										
Vendor ID	Company Name	Contact Person	City	Email	Phone	Business Description	HUB Eligibility	HUB Gender	CMBL Stat	HUB Status
1475357271900	1DZ ENTERPRISE LLC	Debra A. Garcia	ARANSAS PASS	debbiegarc20@gmail.com	361-534-4244	Janitorial Service, Construction Cleanup, Site Preparation, Demolition, Demolition Cleanup,Paving, General Construction, Concrete Work	HI	F	No	Yes
1825390959400	22 CONTRACTING, LLC	Erin Clapp	McKinney	erinclapp@22contracting.com	214-663-9185	General construction contracting	WO	F	No	Yes
1454338911900	2GS, LLC	HUMBERTO GARCIA JR	PENITAS	bgarcia@2gslc.com	956-424-3414	2GS, LLC specializes in the construction of paving and underground utility lines. This includes new and existing street work and all related appurtenances for the installation of water, sewer and storm sewer lines.	HI	M	No	Yes
1461995281600	360 TXC, LLC	Tony LESTER	AUSTIN	dlester@360txc.com	512-229-6440	We provide general contracting and complete project planning and management services. Our vast project portfolio covers everything from 1,000sqft interiors and renovations to 25,000sqft+ ground-up and core-shell buildouts.	BL	F	No	Yes
1842115429700	9 Ether Global Services, LLC	Ariel Mitchell	Houston	9etherglobal@gmail.com	832-236-7497	General contracting services. Also provide the following trade services: drywall, framing, ceiling, painting, flooring, specialties, carpentry, Division 9 & 10, etc.	BL	M	No	Yes
1474951661400	A STATUS CONSTRUCTION	Marisa Rodriguez	FRIENDSWOOD	mr@indicstruction.com	713-859-4658	General Contractor	HI	F	Yes	Yes
1832288563500	A&B EXCAVATION, LLC	Sravan Eadara	FORT WORTH	estimating@abexcavation.com	469-543-7151	Land Clearing, Excavation, Site Preparation, Grading and sloping, Trenching, Demolition, Storm drainage, Pond and lake development and dredging, Driveways and parking lots, Disaster clean up	WO	F	Yes	Yes
1272012151100	A&I Custom Manufacturing, LLC	Ismael Herrera	Brownsville	araceli.ai@hotmail.com	956-592-6527	PLATE AND METAL WORK, MANUFACTURING OF INDUSTRIAL MARINE WORK WITH METAL AND ALUMINUM AND STAINLESS STEEL. BENDING, CUTTING, PUNCHING, SHAPING, WELDIN	HI	M	No	Yes
1742971115700	A.C. CONTRACTING SERVICE, L.L.C.	Ptnr/ARMANDO CONTRERAS	MISSION	lou@rgv.rr.com	956-683-5115	EXCAVATION FOR UNDERGROUND buried CABLE and other UTILITIES.	HI	F	No	Yes
1593827267900	ACE CO CONSTRUCTION, LLC	Eric Gebhart	San Antonio	bettydrennan@acecosa.com	210-494-2338	Parking lot marking and line painting, Parking lot paving and sealing and Parking lot cleaning (e.g., power sweeping, washing) services.	HI	F	No	Yes
1752579021200	ACE CONTRACTORS, INC	ROYALENE MCEACHERN	SAN AUGUSTINE	acecontractors44@gmail.com	936-275-9450	mowing, guardrail,culverts,repair work, dirt hauling,equipment hauling,excavation,track-hoe, bulldozer work, fence install/repair,quardrail insulation and repair,portable potty rentals, small tree trimming and stump grinding	WO	F	No	Yes
1460532886400	ACG Contractors LLC	Victor Alvarez	Houston	monica@acggc.com	281-416-4333	Whether a small or a large scale project, ACG's construction services are delivered within our culture of integrity and projects completed on time and within budget.	HI	F	No	Yes
1752966405800	ACUMEN ENTERPRISES, INC.	Wayne Boyter	DESOTO	wayne@acumen-enterprises.com	972-572-0701	Mechanical HVAC & plumbing contractor, mechanical insulation, & general construction	AI	M	Yes	Yes
1931788048200	ADCOM Enterprises LLC	Carlos Montfort	Brownsville	carlosmontfort95@gmail.com	956-525-3756	Construction and contracting services	HI	M	Yes	Yes
1465359949900	AGGIELAND CONSTRUCTION, LTD.	Britt Jones	WELLBORN	britt.jones@aggielandconstruction.com	979-393-0080	Any general contracting that involves new, old, and remodeling construction.	WO	F	Yes	Yes
1742899224600	AJ Commercial Services, Inc.	Rafalita Avalos	San Antonio	ravalos@ajcommserv.com	210-658-6113	Administration of Contracts: Summary of Work, Quality Control, Project Closeout, etc.; Airport Facility Construction; Airport Facility Maintenance and Repair; Athletic Facility Construction; Athletic Facility Maintenance and Repair; Building Construction	HI	F	Yes	Yes
1200334965600	ALAMO ENVIRONMENTAL, INC. DBA ALAMO 1	President / J. Alex Salas	SAN ANTONIO	jsoto@alamo1.com	210-404-1220	Full service contractor providing general construction, special trade construction, demolition, remediation, abatement, hazardous material disposal, emergency response services, spill response services, and commercial waste services.	HI	M	Yes	Yes
1872687474800	ALAS LLC	Raul Alatorre	DEL RIO	alas.llc@yahoo.com	830-765-7285	General Contracting, Maintenance Commercial/Residential, New Construction, General Services	HI	M	Yes	Yes
1462061957800	ALL MATERIALS CONSTRUCTION, LLC	Lakeisha Brown	NEW BRAUNFELS	allmaterialsconstruction@gmail.com	830-515-6623	we are a general contractor in building also roads and bridges.Lawn maintenance and Janitorial Cleaning, striping paving,painting fencing,concrete,roofing,floors	BL	F	No	Yes
1455294324400	ALPHA ASPHALT AND PARKING LOT CONTRACTOR	Ilina Chavez	EL PASO	iliana@alphapavingep.com	915-667-8303	Alpha Asphalt provides all types of parking lot repairs from start to end. We do Seal Coating, Striping, Crack Fill, and Paving. We also do concrete sidewalks, curb and gutters, and concrete pads.	HI	M	Yes	Yes
1824590952000	AMERICHoiceCONSTRUCTION LLC	PATRICIA FAVELLA	EL PASO	americhoiceconstruction@gmail.com	915-317-5152	Building Construction, General, heavy and trades.	HI	F	Yes	Yes
1463084640100	AMP CONSTRUCTORS, LLC	Amy Morales	AUSTIN	amy@moralesdevelopment.com	512-709-9610	Building Construction, including General Contractors and Operative Builders, Civil construction to include water & waste water utilities, site prep, silt fence	HI	F	No	Yes

1742740609900	AMSTAR, INC.	Mary Flores	San Antonio	tflores@amstarincgc.com	210-927-5705	Multifamily building construction general contractors, Construction management, industrial building (except warehouses), Addition, alteration and renovation general contractors, commercial and institutional building and Roofing contractors.	HI	M	No	Yes
1471528294400	ANGELINA FLOORS & MORE, LP	Kevin Brown	LUFKIN	floorsmorelufkin@outlook.com	936-699-4530	Carpet/Flooring Installation and Removal, Construction, Electrical	HI	M	Yes	Yes
1853004000700	ANVIL ENTERPRISES INC.	DONNA NAYLOR	BOERNE	DONNAN.ANVIL@GMAIL.COM	210-727-3987	CONSTRUCTION, REPAIRS AND MISCELLANEOUS JOB REQUESTS	WO	F	No	Yes
1752902529200	AOC ENVIRONMENTAL, INC.	Matt Birkhead	WICHITA FALLS	customerservice@aocenviro.net	940-692-8989	Asbestos Abatement/Special Construction/Civil Construction. General Contractor.	HI	F	Yes	Yes
1461387592200	ARS SPECIALTY CONTRACTORS, LLC	Elizabeth Yetman Chavez	SAN ANTONIO	elizabeth@garrentx.com	210-736-4224	Our company provides high-quality construction services in the areas of general contracting, federal prime contracting as well as subcontracting in the areas of industrial coatings, large scale concrete construction, and gypsum underlayment and lightweig	HI	F	No	Yes
1833506441800	ASA Elite Logistics		San Antonio	Alfredo@ASAEliteLogistics.com	210-279-2410		HI	M	No	Yes
1262197773000	ASSOCIATED CONSTRUCTION PARTNERS, LTD.	Jillian R. Simpson	BOERNE	jill@acpartners.org	210-698-8714	Heavy, Water & Wastewater Plant Construction, Utility, Electrical, General Construction	WO	F	Yes	Yes
1844445643000	ATX COMMERCIAL, LLC	KRISTIN ASHWORTH	NORTHLAKE	OFFICEATXCO@GMAIL.COM	940-390-6919	EXCAVATION COMPANY - EROSION CONTROL, EXCAVATION, EARTHWORK, DEMO. , MOWING, HERBICIDE, DRAINAGE,	WO	F	Yes	Yes
1871784463500	AXE Industrial, LLC		Lakeway	karenowens.axe@outlook.com	512-970-4146		HI	F	No	Yes
1203122915100	All In One Services	Tammy Britton	desoto	ap.ch@hotmail.com	972-639-0684	Residential Repair Services has over 25 years of combined experience in the home repair & improvement industry. We are a family owned and operated business that started in the late 1990's.	BL	F	No	Yes
1463120331300	All Works Construction Corporation	Jose Saul Cantu	ALAMO	allianceconstructionworks@aol.com	956-702-8700	Bull dozer Services, Root Plow Works, Root Rack and Stacker; Disc Work; Demolition Services; Chain Works; Back hole service; Brush Clearing; Land clearing; Pond Building and Dams.	HI	M	No	Yes
1050632857300	Alonso Excavation & Construction Co., In	justin hayes	San Antonio	info@alonsoserviceco.com	210-637-5287	Poured Concrete Foundation and Structure Contractors, Plumbing, Heating, and Air-Conditioning Contractors and Excavation contractors.	HI	M	Yes	Yes
1542074052200	Armor Construction Co. Inc.	Hector LOYA	EL PASO	hector@armorconstruction.com	915-478-7744	GENERAL CONTRACTOR - REMODEL RESIDENTIAL & COMMERCIAL, FRAMING, DRYWALL, RENOVATIONS, ROOFING, ADDITIONS, PLUMBING, DEMOLITION, WELDING, CONCRETE, PAINTING, ETC.	HI	M	No	Yes
1262840040500	Austin Constructors, LLC	Marcos Medrano	Austin	jenny@austinconstructors.com	512-386-8690	To provide concrete, utility, sidewalk and heavy highway construction services. Firm also provide general construction and residential remodeling scopes.	HI	F	No	Yes
1752686521100	BASECOM, INC.	President / Oscar Oaxaca	FORT WORTH	ooaxaca@basecominc.com	817-589-0050	Building Construction, Including General Contractors And Operative Builders, Electrical Contractor	HI	M	No	Yes
1273088856200	BASIC SDV, INC	Rich Barrick	AUSTIN	bids@basicsdv.com	512-827-6806	Job Order Contracting, JOC, General Contracting, Construction Management, Government Contracting, State Contracting, School Districts, Universities, Medical, Federal, Veterans Administration, IDIQ Contracting	DV	M	Yes	Yes
1464157976900	BBC CONSTRUCTION SERVICES	Veronica Chapa	LAREDO	veronicachp@yahoo.com	210-422-5558	Construction-install;tile,carpet,vct,concrete,sheetrock and metal works.	HI	F	No	Yes
1262358804800	BCC GENERAL CONTRACTOR, LLC	Holly Byrd	TEMPLE	holly@bccgeneralcontractor.com	254-563-6633	BCC is a full service commercial general contractor offering well organized, complete construction services. Services include: New Construction; Tenant Improvements; Construction Management and Pre-construction consultation	WO	F	No	Yes
1030503577500	BCL&D Services	Paul McGregor	Stafford	info@bclservicesllc.com	281-986-9656	Parking Lot Paving & Construction Remodeling (Excluding HVAC, Plumbing, & Electrical)	BL	M	No	Yes
1862301257400	BEL-GRA CONSTRUCTION LLC	Jeanie James	MAGNOLIA	belgraconstruction@gmail.com	281-850-2158	General Contractor for commercial and government construction projects and developments. We can also do metal fabrication work	WO	F	No	Yes
1810966336100	BELLA LUNA ENGINEERING AND BUILDING MAIN	Lorenzo Luna	EL PASO	lorenzo@bellalunaengineering.net	915-888-1777	Bella Luna Engineering is a general contractor that specializes in construction, electrical services, building maintenance for municipalities, large buildings (> 5 Floors), and shopping centers	HI	M	Yes	Yes
1741940175100	BFJ CONSTRUCTION	Sandee Land Fairey	TEXAS CITY	sfairy@bfjconstruction.com	409-948-4388	Renovation and Build-out of Medical Facilities and Hospitals including MRIs, Cath Labs, ICU's, Gama Knives,Linear Accelatorators, Emergency Rooms, Outpatient Diagnostic Facilites, CT Scanners, & Dr. Offices.	WO	F	No	Yes
1320812093400	BL3 Construction Services LLC	Angela Long	Lampasas	angela@bl3texas.com	361-443-0440	Provide dirt work, excavation, grading and land services.	WO	F	No	Yes
1320507295500	BLACKSTONE CONSTRUCTION INC	Junaid Noor	HOUSTON	jn@blackstoneconstruct.com	832-804-8135	General Contractors focusing on site work, development and construction of commercial properties as well as concrete paving	AS	M	No	Yes

1861613957400	BMC LOGOPS, LLC	Michael Breito	ALEDO	mbreito@yahoo.com	817-966-0130	Erosion Control, culverts, grading, concrete demo, new concrete mowing, water transportation, large land maintenance, earth moving DV equipment	HI	M	No	Yes
1742939960700	BORDER DEMOLITION & ENVIRONMENTAL INC	BONNIE SOLIS	EL PASO	bonniesol@borderdemo-enviro.com	915-860-8855	Demolition and Asbestos, Lead and Mold Abatement Contractor.	HI	F	Yes	Yes
1760299430700	BURTS CONSTRUCTION, INC.	Pres./KATHERINE BURTS	TOMBALL	kburts@burtsconstruction.com	281-351-0020	Site and storm	WO	F	No	Yes
1460808938000	BXB GROUP INCORPORATION	Pres.KATHRYN BLAKE	DECATUR	kathryn@bxbgroup.net	817-527-1292	Specialty Construction Contracting	WO	F	No	Yes
1742752904900	Barraza Code Electric, Inc.	Rick Barraza	EL PASO	paulina@codeelectric.us	915-581-6979	ELECTRICAL SERVICES. POWER AND COMMUNICATION LINE AND RELATED STRUCTURE.	HI	M	No	Yes
1760484072200	Baseline Paving & Construction, Inc.	Tanya White	Magnolia	baselineinc@msn.com	281-356-2833	Break Out & Replace Concrete, Ada Modifications	WO	F	No	Yes
1202681085800	C3 ENVIRONMENTAL SPECIALTIES, LP	Dustin Pratt	SCHERTZ	dpratt@c3environmental.com	210-653-7801	Erosion Control/ Land Clearing Services.	HI	M	Yes	Yes
1260368802400	CAPPS-CAPCO CONSTRUCTION, INC.	PresRobyn E Capps	TYLER	robyn@capps-capco.com	903-531-9670	Roadway Construction.	WO	F	Yes	Yes
1752918306700	CARCON INDUSTRIES & CONSTRUCTION, LLC	Arcilia Acosta	DALLAS	aacosta@carconindustries.com	214-352-8515	GENERAL CONSTRUCTION SERVICES-CONSTRUCTION PRODUCTS PURCHASING-TELECOMMUNICATIONS SERVICES	HI	F	No	Yes
1844410207500	CARRILLO STEEL FABRICATION & ERECTORS	Pedro Carrillo	SEGUIN	pedro@carrillosteel.com	512-644-8569	Steel Fabrication and Erectors	HI	M	No	Yes
1752850965000	CARTER CONSTRUCTION	President/CYNTHIA CARTER	FT WORTH	christina@carterconstructioncompany.com	817-244-3622	GENERAL CONTRACTING,EXCAVATION,GRADING, UTILITIES,AND CONCRETE	WO	F	No	Yes
1200547573100	CASIAS CONSTRUCTION, LLC	Frank D. Casias	SAN ANTONIO	frank@casiasconstructionllc.com	210-308-1067	General Contractor Specializing in Commercial Construction	HI	M	Yes	Yes
1473191874500	CBMAA, Inc.	Christopher Patton	Forney	chris.patton@wellingtonfs.com	972-853-1455	General Contracting to include Project Management	BL	M	No	Yes
1742919890000	CEDA-TEX SVCS INC	Fred Odanga	CEDAR PARK	contact@cedatex.com	512-339-0155	General construction. New construction, Site, drainage, Interior drywall, plumbing, electrical Painting ,concrete work etc	BL	M	Yes	Yes
1261341513700	CEDAR BEETLE, LLC dba BADER CONSTRUCTION	KATY BADER	HONDO	trey@cedarbeetle.com	830-426-6453	Right of way services including clerling, environmental work, gates, roads and culverts. All types of land clearing including dozing, mulching, tub grinding, hand cutting, etc. Excavation services including lake and pond construction	WO	F	No	Yes
1851648613300	CHAPA'S CUSTOM SERVICES LLC	Erick Chapa	ALVIN	chapascustomservices@gmail.com	281-716-7968	site preparation, demolition, grading, grubbing, land clearing, excavating, welding, fabrication	HI	M	No	Yes
1428192886200	COLEMAN GLOBAL ENTERPRISES-CGE	Jermaine Lamont Coleman	UNIVERSAL CITY	cge242008@outlook.com	210-884-2563	Coleman Global Enterprises is a verified Service-Disabled Veteran-Owned Small Business (SDVOSB) that provides our clients with medical products along with Educational Professional Development, marketing, advertising, and theatrical performances.	BL	M	Yes	Yes
1852359466300	COLLABORATE CONSTRUCTION COMPANY, LLC	Deborah Campbell	MISSOURI CITY	ccc@houston@gmail.com	713-539-3522	Commercial construction, streets, buildings, bridges, concrete, marine construction, commercial diving.	HI	F	No	Yes
1454970992200	COLSTON CONSTRUCTION INC.	Jacob Colston	FORT WORTH	amanda@colstoninc.com	817-487-6672	General Construction Services, in addition to self performance of general construction work	DV	M	No	Yes
1861328327600	CONFORMANCE LLC	MIRZA FARJAD BAIG	RICHARDSON	Farjadbaig@gmail.com	214-430-8492	Engineering Consultant and Contractor	AS	F	No	Yes
1200074905600	CONSTRUCTION ZONE OF TEXAS, LLC.	Tamra K Crosson	AUBREY	sandyb@cziglobal.com	940-365-1366	COMMERCIAL GENERAL CONTRACTOR - REMODEL/NEW CONSTRUCTION	WO	F	No	Yes
1272293470500	COPPERA, LLC	Rhonda Dowdy	TAYLOR	office@copperaco.com	512-365-1838	New Plumbing Construction & Remodel Plumbing Construction	WO	F	No	Yes
1751991843100	COX CONCRETE CONTRACTORS, INC.	Brenda Jones	NACOGDOCHES	bjones@coxcontractors.com	936-564-6500	Concrete Construction, General Construction, Construction Management, Design-Build, Architecture, Interior Design.	WO	F	Yes	Yes
1300402089000	CRAIGS DIRT SERVICE, LLC	Brittany Brown	LINDALE	brittany@craigsdirtservice.com	903-882-5096	Trucking, hauling, construction, dirt excavation, demolition	WO	F	Yes	Yes
1862576645800	CRC CONTRACTING INC	Christopher Harris	WHITEWRITE	crcinfo@crccontracting.com	817-235-1781	General contractor, can handle any modern commercial construction technique. Partner with experienced reliable subs. Buildings, commercial properties, commercial electric, structural steel, restoration, upgrading existing building, commercial plumbing.	DV	M	No	Yes
1462706182400	CT WALKER, LLC	CASSANDRA WALKER	AUSTIN	ct.walker@austin.rr.com	512-300-3080	General contractor, site work, concrete, utilities, fencing, landscaping, demolition, drywall, roofing, painting, construction management, material and equipment suppliers	BL	F	Yes	Yes
1874826807700	CT4 CONSTRUCTION LLC	Christopher Trevino	BEDFORD	ctrevino@trevinorealtygroup.com	817-808-8144	General and Civil Construction and Engineering	HI	M	Yes	Yes
1851538144200	CULTURED PEARLS, LLC	Marsha Dorsey-Outlaw	HOUSTON	info@marshadorseyoutlaw.com	832-893-7447	Cultured Pearls specializes in Custom Art Solutions including Civic and Functional Art Design, Installation and Management. We specialize in Streetscape, Landscape and Interior Enhancement. We facilitate Multi-Cultural Training Programs and Events.	BL	F	No	Yes
1800547507600	CVI DEVELOPMENT, LLC.	Karl Daniels	AUSTIN	karldaniels.mac@me.com	512-944-0280	Building Construction, including General Contractors and Operative Builders	BL	M	No	Yes
1460640097700	CWA FEDERAL CONSTRUCTION	Marcee Thomas	WACO	mthomas@cwaconstruction.com	254-772-9977	We provide design/build, construction management, and general construction services.	WO	F	No	Yes
1800920788900	Calvo Construction, Inc.	Juan CALVO	Grapevine	jcalvo@calvoconstruction.com	817-394-3912	Underground Utilities Construction	HI	M	No	Yes

1742973892900	Campos Utilities, Inc.	Campos Richard	New Braunfels	rcamposutilitiesinc@msn.com	830-643-0015	Construction, General: Backfill Services, Digging, Ditching, Road Grading, Rock Stabilization, etc.; Construction, Sewer and Storm Drain; Construction, Utility and Underground Projects; Maintenance and Repair, Sewer and Storm Drain, Including Removal; Ma	HI	M	No	Yes
1742471700100	Con-Cor Inc.	Cy Canales-Jary	San Antonio	cyjary@con-corinc.com	210-375-8484	Building construction, general contractor, remodeling contractor	HI	M	No	Yes
1300505867500	Consolidated Installation Support, LLC	Joseph Monroe	SAN ANTONIO	joe@vetcis.com	210-387-0097	General Contracting construction company, concrete, sidewalks, framing, curb and gutters, forming, site cleanup, park renovations, hospital labs renovations.	BL	M	Yes	Yes
1201621237000	Crain Group, LLC	President Phillip B Crain	PEARLAND	brad@craingroup.com	713-436-8727	Commercial General Contracting, construction and program management, and consulting.	HI	M	No	Yes
1200265986500	Creed Construction, Inc.	Chester Reed	Mansfield	ruby@creedci.com	682-518-8835	Green builder and certified installer of AAC (Autoclaved Aerated Concrete). Capable of engineering and building from ground up. Total mason builder, brick, block, stone, stucco, concrete restoration, cleaning, caulking, dampproofing and repair.	BL	M	No	Yes
1742523918700	D & S S CONSTRUCTION, INC.	Pres./JANNA SCHURY	CORPUS CHRISTI	janna@dssconstruction.com	361-992-3566	GENERAL CONTRACTOR.	WO	F	No	Yes
1752888256000	D. Grimm, Inc.	Dawn Harvey	PLANTERSVILLE	dawn@dgrimminc.com	936-228-7802	Site preparation, earth work, foundation installation, erosion control, Right of Way Clearing and Maintenance, foundation installation, pad installation, clearing and grubbing	WO	F	No	Yes
1814894430100	D4 LAND SERVICES LLC	Clinton Dempsey	KURTEN	d4landservices@gmail.com	979-676-1985	Land Clearing, Excavation, Forestry Mulching, ROW, General Contracting, Project Management, Site Work, Concrete, Masonry, MEP, Damp Proofing, Caulking, Sealing, Fire Safing and Selective Demolition	DV	M	Yes	Yes
1562589888500	DECENT CONSTRUCTION COMPANY, INC	SYED A HASHMI	PLANO	construction.decent@gmail.com	214-846-5113		AS	M	No	Yes
1843513615700	DIESEL UNITED LLC	Cornell Knight	COMANCHE	cornell@dieselunited.org	888-437-5177	We heal the world by managing farms & ranches that house livestock and poultry & provide administration & consulting services to those who improve the making, care, & use of renewable energy along with advancing affordable accommodations to all.	BL	M	No	Yes
1205092380900	DLC CONSTRUCTION, INC.	Cysel Acosta de la Cueva	EL PASO	delacu@live.com	915-771-7580	Earthworks, Concrete and Asphalt Paving	HI	F	Yes	Yes
1824288646500	DMA CONTRACTORS INC.	Donna Allphin	PLANTERSVILLE	dallphin@sbcglobal.net	936-894-3533	Guardrail installation and repair, underground construction, directional boring, water well drilling, road and driveway building, backhoe and dozer work, mowing, all farm related construction, and concrete work, catering events	WO	F	No	Yes
1261672970800	DNA Trucking, Inc.	Arthur Pena	RICHMOND	dnatrucking@yahoo.com	281-650-5518	Dump Truck Hauling Service; Supplier of Sand, Rock, Gravel and Other Earth Materials	HI	M	No	Yes
1921001449400	DORSETT CONTRACTING, LLC	Brandy Dorsett	BUDA	accounting@dorsettcontracting.com	512-395-5003	Civil Construction, Excavation, Site Work, Concrete, Underground Utilities	WO	F	Yes	Yes
1883737586600	DRB RECON SERVICES, LLC	Dillon R Burran	KENNARD	drbrecon@outlook.com	936-204-1913	Land/Forest/Road maintenance mulching, mowing, boring, clearing - right away, easement, forest thinning, dirt work etc	DV	M	Yes	Yes
1300590854900	DRC CONSTRUCTION LLC	Owner/Dawn Cockerill	BEAUMONT	drc.construction@yahoo.com	409-223-1420	DRC Construction is a residential custom home builder with experience in apartments, condos, townhomes, storm restoration, and light commercial. We can fulfill all your needs at an affordable price and in a timely manner with no exception to quality.	WO	F	No	Yes
1464469415100	DYNAMIC BASE CONSTRUCTION, LLC	Lisa Thoma	BURLESON	l.thoma@tarkettsports.co	817-303-3484	Sports field and supportive athletic structures, natural grass, synthetic and artificial surfaces	HI	M	Yes	Yes
1844336908900	Demotik Construction Services, Co.	FELIX ROIGUEZ	HOUSTON	felix@develotik.com	305-956-6009	Construction remodel, demo, build back, commercial retail, high rise office tower, ground up, and signage.	HI	M	No	Yes
1800610617500	Diamond Eight Industries, LLC	Alissa Perez	SANTA ROSA	diamond8industries@yahoo.com	956-636-1429	Asphalt Paving, Site Work, Demolition, Excavation, Underground Utilities, Grading and Concrete, Ready Mix Concrete	HI	F	No	Yes
1862420681100	DuPre Site Services, LLC	Karen Owens	Buda	dupresiteservices@gmail.com	512-529-8096	land management and land clearing	WO	F	No	Yes
1901025179100	EARTHCO LANDSCAPE CONSTRUCTION, LLC	Earthco Landscape Construction llc	GEORGETOWN	earthcolc@aol.com	512-818-7015	landscape/irrigation/design/drainage/erosion control supply & install/dirt work/ excavation/trenching/hauling /concrete supply/concrete installation/demolition/ retaining walls/tree trimming/tree removal/clearing/ heavy equipment & operators/pipe supply	BL	M	Yes	Yes
1820571726900	EAS CONTRACTING, L.P.	LAWRENCE PINZEL	PRINCETON	info@easlp.com	972-590-5576	Electrical Utility Contractor	BL	M	Yes	Yes
1742702517000	ENVIRONMENTAL RECONSTRUCTION SERVICES,	Kelly Brisco	FARMERSVILLE	kelly@ersfuelinstallation.com	972-524-2946	INSTALLATION & REMOVAL of underground and above ground fuel storage tanks, vehicle service equipment, underground piping, and dispensers.	WO	F	Yes	Yes
1923074620800	EP GEM ENTERPRISES LLC	George Cepeda	El Paso	gcepeda@valor-gc.com	915-740-6917	SDVOSB GENERAL CONTRACTOR WITH 20 YEARS IN UNDERGROUND UTILITIES, PAVING, CONCRETE AND PIPELINE WORK.	HI	M	Yes	Yes

1810698979300	ESCOS CONSTRUCTION SERVICES, LLC	Jaime Escobar	FORT WORTH	escoscs@yahoo.com	817-707-1128	We are a statewide licensed growing company in the DFW metroplex and surrounding areas. Escos Construction Services offers Construction project cleaning, material delivery, dirt and haul off services as well as excavation and demolition.	HI	M	No	Yes
1881184212100	EXECUTIVE SEARCH PARTNERS OF TEXAS LLC	Brandon Woods	BULLARD	brandonw@executivesearchpartn.com	903-279-7930	We are a SDVOSB specialized organization utilizing a wide array of products and services to bring value government agencies.	HI	M	No	Yes
1820969765700	Eischen's General Contracting, LLC	Ava Sharifian	Austin	ava@egcatx.com	512-445-0128	To provide general contracting services that focuses on remodeling residential properties and buildings. Also firm maintains trails and bridges. The firm mainly provides landscaping services.	WO	F	No	Yes
1371623274200	El Dorado Services, Inc	Frank Lopez	Houston	eldoconstruction@gmail.com	713-530-6204	General Construction and Repairs, Concrete Construction, Dirt Work, and Underground Utilities (Storm Line and Sanitary Sewer Lines) Erosion Control, Rip Rap, concrete sidewalks driveways streets,	HI	M	No	Yes
1832535932300	FACILITY MANAGEMENT CONSULTING, LLC	OMAR MONT-LOUIS	FRESNO	montlouis@fmexpert.com	281-995-1111	Consulting and construction Management	BL	M	No	Yes
1832540617300	FIRSTSTOP, LLC	Sara Aranda	SAN ANTONIO	sara@the1ststop.com	210-455-1505	General Contracting; AC and vent systems test, balance pre/post new system demo/install windows, doors, floors, fixtures, electrical, plumbing, according to contract. Esthetically prepare product presentable to client, while staying on budget and time.	HI	F	Yes	Yes
1821152199400	FORREST INDUSTRIAL GROUP LLC	Jeffery Forrest	TOMBALL	forrestindustrial.llc@gmail.com	832-620-2321	Forrest Construction specializes in residential and commercial remodeling and construction services including carpentry, mill-work, flooring, and also provides project management services including estimation.	BL	M	No	Yes
1742784213700	FOSTER CM GROUP, INC.	Paul Foster	SAN ANTONIO	satirahf@fostercmgrou.com	210-804-1004	Program / Construction Management	BL	M	Yes	Yes
1882298753500	FRAUSTO - CASTILLO CONSTRUCTION GROUP, L	Alfredo Frausto	SAN ANTONIO	info@fconstructiontx.com	210-737-4791	Construction management, commercial and institutional building, Poured Concrete Foundation and Structure Contractors, Framing contractors, Masonry Contractor	HI	M	No	Yes
1824334572700	FREEDOM CS, LLC	Clint Hobbs	TYLER	freedomconstruction97@gmail.com	903-360-1158	Excavating, paving, demolition, site work, land clearing, aggregate hauling.	WO	F	No	Yes
1272425295700	FRONTLINE SUPPORT SOLUTIONS, LLC	Jose Perez	SAN ANTONIO	todhiambo@frontline1.com	210-630-6750	Frontline Support Solutions, LLC is a general contractor specializing in commercial and industrial construction. Additionally, we provide facility support services to large commercial and industrial parks, and military installations.	HI	M	No	Yes
1834676727200	FULCRUM CONTRACTING GROUP LLC	ALEJANDRA JARAMILLO	EL PASO	projectmanager@fulcrumcontracting.net	915-892-9937	Concrete, Rockwall, Earthwork	HI	F	No	Yes
1743002047300	Five B's Construction & Utilities, Inc.	PresidentBrenda K Lackey	SPRING BRANCH	fivebsconstruction@gvtc.com	830-980-2714	Site work, utilities, land clearing, backhoe work, concrete, bobcat services.	WO	F	No	Yes
1743003047200	Five B's Construction & Utilities, Inc.	PresidentBrenda K Lackey	SPRING BRANCH	fivebsconstruction@gvtc.com	830-980-2714		WO	F	No	Yes
1870744174900	Five Woods LLC	Laolu Yemitan	Houston	laolu@5woods.net	832-202-2233	Real Estate & Integrated Facilities Maintenance Services (Janitorial & Landscape)	BL	M	No	Yes
1743002355000	G & E ESCOBEDO CONSTRUCTION, INC.	Geronimo Escobedo	MISSION	gescobedo@aol.com	956-585-1429	Excavation, Bores, Bury Telephone Cable	HI	M	Yes	Yes
1752205887800	G. L. MORRIS ENTERPRISES, INC.	Pres./Marla K. Murphy	CARROLLTON	marla@sun-belt.com	817-877-0866	Environmental Contractors, Excavation, Tank Removal, Drum Transportation, Soil Transportation & Disposal, Demolition, Hazardous Materials Handling, Treatment System Installation, Environmental and Geotechnical Drilling	WO	F	No	Yes
1270296441700	G2 CONTRACTORS, LLC	Heather McGlasson	Mason	heather@g2contractors.com	817-739-6560	General Contractor / Certified Construction Manager (CCM) who primarily works with land management and historical government agencies in all Regions within the State of Texas. Performs any type and size of project in Texas.	WO	F	Yes	Yes
1834050961300	G2 Construction Services, Inc.	Jyl Gibson	Georgetown	jyl@g2csinc.com	512-688-5725	Commercial general contractor specializing in General Contracting, Design Build, Construction Management, Planning & Development, Pre-Construction Consulting. TIPS JOC awarded contractor.	WO	F	Yes	Yes
1810633810800	GARCO INDUSTRIES, INC.	Blanca Garza	MCALLEN	garcoutilities@yahoo.com	956-783-1695	Utilities and paving	HI	M	No	Yes
1741819567700	GAYLE ASSOCIATES	OWNERRAYMOND GAYLE	HOUSTON	jrgaylessoc@aol.com	713-256-5506	GENERAL CONTRATOR, CONCRETE SPECIALIST, INTERIOR BUILDING RENOVATIONS.	BL	M	No	Yes
1464815031700	GLOBALIZE AMERICAN SAFETY, LLC	Margaret Johnson	RICHMOND	GlobalizeAmerican@gmail.com	713-301-4336	Demolition, Drywall & Insulation Installation, Door, Windows, & Cabinet Installation, Finishing Work, Flooring, & Framing/Hauling/Debris Removal via Pickup Truck & Janitorial Services	BL	F	No	Yes
1465571461700	GMC CONSTRUCTION MANAGEMENT SERVICES,	Gregory M Crain	ATHENS	gmccms@yahoo.com	214-605-0609	Commercial build outs. Framing, Drywall, Store Front Glass, Flooring, Lighting (Electrical), Painting, Plumbing, Video and Security Systems, and Land Clearing.	BL	M	Yes	Yes

1853479887300	GRANCHELLI CIVIL CONSTRUCTION, LLC	James Granchelli	MCALLEN	jim@granchelliconstruction.com	956-928-1122	Heavy civil, earthwork, utilities, concrete structures, roads, streets, bridges	WO	F	Yes	Yes
1830634866700	GREAT LIFE ASSET MANAGEMENT	Dione Newman	DALLAS	greatlife.management@gmail.com	214-732-2449	We do all repairs and renovations to both residential and commercial properties. We also specialize in insurance consulting, adjusting and claim services. We write auto and home policies & review coverage with any entities in search of proper coverage.	BL	F	Yes	Yes
1264438537400	GREENWORLD CONSTRUCTION	Michael Torres	AUSTIN	admin@gwmaterials.com	512-797-9876	Framing, Sheathing, Decking, Roofing, Exterior Siding, Insulation, Concrete Foundations, Drywall, Patios, Decks, Fences, multifamily, student housing, single family, industrial	HI	M	No	Yes
1200797158800	Gap Engineering, Inc.	Mike Homma	Katy	mhomma@gap-eng.com	281-578-0500	Gap Engineering is a full service general contractor specializing in quickly mobilizing and executing projects for state and local government	AS	M	No	Yes
1711038225000	Globe Builders Inc.	Angelina Rodriguez Chavez	EL PASO	angierodriguez@globebuilders.com	915-533-8700	Building Construction, including General Contractors, and Operative Builders	HI	F	No	Yes
1472318149200	Gutier LLC	Michael Gutierrez	Missouri City	Michael.gutierrez@gutier.com	832-830-8292	Roofing & Concrete Services (Demolition & Repair)/ Construction Management	HI	M	No	Yes
1260439585000	H3 CONSTRUCTION, LLC	Roxanne Hunt	ROANOKE	linda@h3-construction.com	940-295-4488	Concrete Work, Concrete Cutting/Coring, Wall Sawing, Electric Sawing, Flat Sawing, Selective Soft Demolition, Concrete Repair/Paving/Removal, Excavation, Hydro Excavation, Dirt Work, Ground Penetrating Radar, Roll Off Dumpster Rentals,	HI	M	No	Yes
1271774963900	HAMPSHIRE CONSTRUCTION & HAVOC SERVICES	BOBBY HAMPSHIRE	BUNA	colean@hampshireconst.com	409-751-6826	General Contractor	WO	F	No	Yes
1464025568400		JACOB URIAS	MIDLAND	urias_jacob80@yahoo.com	432-556-3221	General Contractor	HI	M	Yes	Yes
1464228019300	HAWKEYE ENTERPRISES LLC	William B Hendricks III	DRIFTWOOD	Highway124@gmail.com	512-627-4866	General construction, remodeling and maintenance services.	DV	M	Yes	Yes
1461752546500	HCE CONSTRUCTION GROUP, HEAVY ROADWAY CONSTRUCTION SERVICES, LLC	CEO Chris Rowland	GRAND PRAIRIE	chris@hceconstructiongroup.com	214-398-7448	interior finish-out, general construction	BL	M	Yes	Yes
1383884246900		Mario Alcantara Cano	CEDAR PARK	mario@heavyroadway.com	512-567-8710	Firm provides highway construction services. Excavation and demolition services, and site clean-up.	HI	M	No	Yes
1475308100000	HERR METALS AND FABRICATION	Irma Herrera	BROWNSVILLE	herr1metal@yahoo.com	956-504-9450	Welding and Fabrication. Sale of Steel, Metals and Industrial Plastics.	HI	F	No	Yes
1900386225700	Horns Crew Trucking LLC	Alvin Horn	Longview	hornscrowhornscrew@yahoo.com	903-387-2059	Hello! We provide Freight transport,cleans up Construction, Waste disposal hauling,Mowing, Landscaping, Disaster remedies,Towing,Hot Shot Service,and Heavy civil engineering work.	BL	M	Yes	Yes
1205902011000	IMANI QUALITY CONCEPTS, LLC	Hardy Jones III	BEAUMONT	imaniqualityconcepts@gmail.com	409-842-4700	New construction, remodeling, janitorial services and debris removal provided for residential and commercial.	BL	M	Yes	Yes
1883991989300	IMPERIAL TOTAL SOLUTIONS LLC	Ben Adeleke	Arlington	info@imperialtotalsolutions.com	469-412-5788	The company specializes on small to medium size projects, Project planning, application design, consultancy and general contracts.	BL	M	Yes	Yes
1821302910300	J&E SIFUENTES LLC	Javier Sifuentes	HOUSTON	j.esifuentesconstruction@gmail.com	832-690-7872	We offer Concrete such as Parking lot, Driveways, Sidewalks, Curbs, Building Slabs.etc.- Another Trade we offer is Flooring Services such as wood, vinyl, stone, brick pavers, stamped concrete, polish floor..etc.	HI	M	No	Yes
1383808023500	J. RIVAS CONSTRUCTION LLC	Jorge A. Rivas	Houston	j.rivasconst@yahoo.com	346-401-7105	We perform many waterline underground utilities, concrete paving and repair, sanitary and storm sewer new and existing, excavation and earth work, drainage and erosion control	HI	M	No	Yes
1760386492100	J. W. GARRETT & SON, INC.	Pres/Colin Garrett	BEAUMONT	natasha@gandenterprises.com	409-883-5465	This company is a general contractor that specializes in commercial and industrial construction. This includes new construction, remodel, design build, etc. We also provide maintenance contracts.	WO	F	No	Yes
1742527948000	JACQUEZ CONSTRUCTION AND TRUCKING LLC	Billy Jacquez	TOMBALL	billy.jac@outlook.com	832-526-8763	Construction Services, Concrete Structures, Dirt Work, Sand Blasting and Painting, Underground Utilities, Bulkheads, Boat Ramps, Pier Building, Tank Leak Repairs, Tank Building General Contracting	HI	M	Yes	Yes
1201931167400	JAMCO Ventures, LLC	Joe Muniz	San Antonio	joe.muniz@jamcoventures.com	210-270-7609	General Contractor, Construction, Sewer, Concrete, Utilities, HVAC, Electrical, Communications, Computer Cabling, Fire Alarm & Protection, Cooling Tow	HI	M	No	Yes
1262401128900	JANES PAVEMENT SERVICES, INC.	Ella L JanesPresident	HUNTSVILLE	annm.janes@sbcglobal.net	936-293-8581	We are a Small Business Specializing in Concrete and Asphalt Paving. (Commercial & Residential).	WO	F	Yes	Yes
1113657737300	JERRY DALE, INC.	Jerry Dale	DALLAS	office@bluesteelgc.com	972-890-3681	Blue Steel General Contracting provides complete construction and remodel for Commercial & Residential.	BL	M	No	Yes
1821331961100	JERSON'S CONCRETE LLC	Jerson's Concrete LLC	HOUSTON	jersonsconcrete@yahoo.com	832-873-9997	Ready Mix Delivery Services Build foundations, sidewalks, driveways, parking lots , etc	HI	F	Yes	Yes
1383841081200	JF Construction Management Group	CEO JEAN FREEMAN	EULESS	msjfreeman1@gmail.com	817-707-9126	Scope of work driveways, curbs cutter, parking lots, sidewalks repair and install guardrail construction management	BL	F	No	Yes
1262258446900	JLG STRUCTURES, INC.	Pres./JESUS LOPEZ	HOUSTON	jesse@jlgstructures.com	281-741-8808	Concrete Construction, Site Work	HI	M	No	Yes

1833400394600	JM Transport LLC	Jeffrey Martinez	Buda	jmtransport2019@gmail.com	512-995-6288	JMT Provides Transportation Services, Site Preparation Contractors, Demolition Services, Construction, Sand and Gravel Mining, Specialized Freight and General Freight Trucking to State & Federal Government, Private Companies & General Customers.	HI	M	Yes	Yes
1201628628300	JMR DEMOLITION, LTD.	Martha Robles	EL PASO	jesse.robles@jmr-demolition.com	915-858-0376	Demolition of Commercial and Residential Properties; Interior and Exterior, For Private Owners and/or General Contractors.	HI	M	No	Yes
1204274008900	JON TUCKER CONSTRUCTION, LTD.	ALLISON TUCKER	BRYAN	office@jontuckerconstruction.com	979-589-3471	Demolition, earthwork, concrete foundations, structural concrete, curb & gutters, site concrete, concrete sawcutting	WO	F	No	Yes
1760416259800	KA-TEX CONSTRUCTORS INC	RENE GRIFFITH	HOUSTON	rene@katexconstructors.com	713-692-0707	GENERAL CONTRACTOR. COMMERCIAL CONSTRUCTION/OFFICE BUILDOUT, ETC.	WO	F	No	Yes
1742520857000	KELLY BURT DOZER, INC.	Sharon Burt	BRYAN	burtdozer@gmail.com	979-778-1902	Sitework Contractor Resident & Commercial. Sand, Gravel & other materials.	WO	F	Yes	Yes
1202112296000	KIESCHNICK GENERAL CONTRACTORS, INC.	DANA KIESCHNICK	WELLBORN	dana@kieschnickgc.com	979-690-0710	COMMERCIAL GENERAL CONTRACTOR SPECIALIZING IN SITEWORK & UNDERGROUND UTILITIES	WO	F	No	Yes
1264437690200	KRKONOS & CEPHI, LLC	Willis Hunt	DALLAS	bid@krkonos.com	469-772-0056	Oversee the planning, design, construction and/or maintenance of projects, buildings or facilities.	BL	M	Yes	Yes
1260653287200	Keystone GC, LLC	Francisco Guillen	EL PASO	Fguillen@Keystone-ce.net	915-562-4159	CONCRETE PAVING & INCIDENTALS; FENCING; MINOR STRUCTURES; REST AREAS TX23412	HI	M	No	Yes
1208072757600	Kocurek Land Improvement, Inc	Amanda Kocurek	Banquete	Amanda@Klearthmovers.com	361-500-2663	Heavy construction.	WO	F	Yes	Yes
1742939910200	L & G CONCRETE CONSTRUCTION, INC.	President/Erasmio Lopez	MERCEDES	bids@lgconcrete.com	956-565-6334	Concrete construction specializing in Title walls, foundations and concrete paving.	HI	M	No	Yes
1271753727300	L&M Aerial & Underground, LLC	Melanie Cornish	Midlothian	melanie@landm-utility.com	214-912-1282	We are currently involved in trenching, boring, aerial, splicing, pole placement, line locating and management services in the Utility Industry.	WO	F	Yes	Yes
1823476685700	LA Services LLC	Chad Simpkins	Granbury	af.laservices@yahoo.com	940-521-2534		WO	F	No	Yes
1852789510800	LAFORTE CONSTRUCTION, LLC.	Orlando Carrillo Maffei	DALLAS	orlando@laforteconstruction.com	305-316-2277	Concrete Roads, Parking Lots, Driveways, Sidewalks, Curbs, Gutters, Residential Leadwalks, Ramps, Retaining Walls, Floors, Columns, Walls, Stairways, Patios, Slabs, Pavers, Roofs, Kitchens, Bathrooms	HI	M	No	Yes
1742945219000	LASALLE AFFORDABLE BUILDERS LLC	Maribel Morales	Castroville	maribel@lasalleab.com	210-415-7912	Addition, alteration and renovation general contractors, commercial and institutional building, Concrete finishing, Concrete product (e.g., structural precast, structural prestressed) installation	HI	F	No	Yes
1270740505100	LDC PAVING INCORPORATED	Chawauí Davis	HOUSTON	estimates@LDCpaving.com	832-640-7296	Provides complete pavement maintenance, marking, concrete wheel stop installation, and signage services for commercial parking lots and roadways.	BL	M	Yes	Yes
1451729429500	LEVIS CONSULTING GROUP, LLC	Monica Bailey Jackson	ARLINGTON	monica@leviscg.com	817-946-7827	General Contractor- Construction Management and Program Management	BL	F	No	Yes
1813219819500	LOCKE CONSTRUCTION SERVICES, LLC.	Angie Harrison	N RICH HILLS	angie@lockecstx.com	214-549-1717	General Commercial Construction Services and Equipment Acquisition.	WO	F	No	Yes
1261821531800	LOPEZ UTILITIES CONTRACTOR, LLC	Ricardo M Lopez	SOUTH HOUSTON	Rm.lopez@sbcglobal.net	713-987-9719	We focus on the reconstruction and new construction of underground utilities.	HI	M	No	Yes
1473293087100	LOUIS & WHITNEY MANAGEMENT, LLC	Brady Mont-Louis	FRESNO	omar@valuecmgmt.com	832-340-3641	Construction, Construction Management	BL	M	No	Yes
1820775416100	LOYOLA CONSTRUCTION, LLC	Jessica Loyola	NEW BRAUNFELS	loyolaconstructionllc@gmail.com	830-743-5336	We offer all concrete related jobs weather it be New foundations, sidewalks, curbs , parking lots. We also do repairs to buildings like roof repairs, floors, walls etc.	HI	F	No	Yes
1364554184100	LSJ TRUCKING, INC.	Lesley J Juman	BEAUMONT	lsjtrucking@att.net	917-709-7160	Trucking of goods for groundwork projects. Example of materials is sand, gravel asphalt, aggregate and excavation. We do haul off and haul in of materials.	AS	M	No	Yes
1742503615300	Lozano Construction Co., Inc.	Pete Lozano	San Antonio	rosanloza@aol.com	210-626-2880	BUILDING AND CONSTRUCTION	HI	F	No	Yes
1742490361900	MALTBY BUILDERS, INC.	SANDRA MALTBY	KINGSVILLE	maltbybuilders@sbcglobal.net	361-592-8426	COMMERCIAL & RESIDENTIAL-NEW & REMODELING	WO	F	No	Yes
1823660718200	MAMMOTH FOUNDATION REPAIR, LLC	Edgar Aguilera	CORPUS CHRISTI	mammothfoundationrepair@gmail.com	361-876-2722	General Contractor- residential & commercial construction-framing, concrete, roofing, electrical, plumbing, painting, renovations, new construction, design build	HI	M	Yes	Yes
1261404837400	MARIO L CARLIN MANAGEMENT, LLC	Mario Carlin	ROUND ROCK	MARIOCARLIN@AOL.COM	512-417-7495	Heavy Construction other than Building Contracts	HI	M	No	Yes
1752570370200	MARTIN GONZALES, INCORPORATED	VP/ Adrian Gonzales	ANDREWS	adrian@martinsinc.com	432-523-6522	OIL FIELD SERVICES, CONSTRUCTION, Environmental Remediation, Concrete, Cement, dozer, excavator, mower, shredder, backhoe, roustabout, haul truck, pipe, vacuum, backhoe, road construction, road maintenance	HI	M	No	Yes
1832800982600	MAXIMUS CONSTRUCTION, LLC	Elizabeth Sturgill	CYPRESS	liz@maximustexas.com	832-557-7972	Our services include residential renovations, remodels, and new construction. We also conduct commercial construction services.	HI	F	Yes	Yes
1871881659000	MC4 Land Development, LLC	Melinda Pollard	Bryan	mc4land@gmail.com	512-789-3275		WO	F	No	Yes
1462780616000	MCCARTHY WILD SERVICES, INC	Tammy McCarthy	FORT WORTH	tammy@mwitx.com	817-781-0769	Construction & Insulation	WO	F	Yes	Yes

1843832603700	ME CONTRACTING LLC	Mickela Esquivel	DALLAS	ME.Contracting.TX@gmail.com	214-699-1378	Provider of contracting network for commercial and industrial external and interior construction, highway and street construction.	HI	F	No	Yes
1823354733200	MEL Properties	Ermilo Elizondo	Houston	melproperties@sbcglobal.net	832-971-5100	Commercial Construction, Demolition, Railroad Construction, Civil Work, Land Clearing, Dirt Work, Excavation, Contracting, Preservation of Residential and Commercial Properties, Remodeling Homes, Marine Sheet Piling	HI	M	No	Yes
1205250740200	MELA CONTRACTING, INC.	President / Leopoldo R. Mendoza	RHOME	paul@melacontracting.com	972-347-5260	Construction of Municipal Projects including Water/Wastewater Treatment Facilities, Utilities, Pump Stations and Lift Stations.	AS	M	No	Yes
1453783615800	MFS SYSTEMS, LLC	Melissa Smith	Pearland	melissasmithpm54@gmail.com	502-322-5635	construction project management services, supply chain, business development	BL	F	No	Yes
1861934354600	MID-TEX CONTRACTING LLC	BRENNA SIMS	WHITNEY	brenna@mid-texcon.com	254-495-5665	General constructions services including MEP.	WO	F	No	Yes
1263344612000	MILCON CONSTRUCTION, LLC	Armando Aranda	SAN ANTONIO	rocky@milconco.com	726-202-3950	Addition, alteration and renovation, general contractors, industrial building (except warehouses) , Construction management, commercial and institutional building, All Other Specialty Trade Contractors	HI	M	No	Yes
1522381883000	MIRADOR ENTERPRISES, INC	Contact Person	EL PASO	ydiaz@miradorenterprises.com	915-546-4111	Facilities Maintenance and Management, construction management and Environmental Services	HI	F	Yes	Yes
1742741319400	MISSION PLUMBING COMPANY	Larry Mendoza Jr	EL PASO	missionplumbing@elp.rr.com	915-630-6791	All PLUMBING SERVICES,REMODELS,TI'S, NEW CONSTRUCTION,INSTALLATIONS,ADA,SMOKE TESTING water heaters, water,sewer,gas,air lines,sand ,grease traps,slab leaks,cancellations,pipe diagnosis,air dryers,sewer pumps,lift stations,custom bathrooms,re-routing	HI	M	No	Yes
1833050304800	MIZA OILFIELD LOGISTICS, INC.	UCHENNA OKWULEHIE	HOUSTON	JAMAIL@MIZALOGISTICS.COM	832-667-8401	Construction services.	BL	M	No	Yes
1742890583400	MLP Ventures Inc.	Liborio Perez	Von Ormy	mlp@att.net	210-623-8172	General Contractors specializing in remodeling and new construction. Scope of work includes any and all phases of construction including design/build, project management, quality control, and specific trade construction (arch, mech, elect work).	HI	M	Yes	Yes
1205466382300	MSU Industries, LLC	Sheila Page	FORT WORTH	sheila@msuindustries.com	817-797-6280	MSU Industries, LLC is a Certified WBE that provides concrete work like curbs and gutters, driveways, sidewalks, slabs, ADA ramps, etc.	WO	F	No	Yes
1832684578300	MUDDY BOOT CATTLE COMPANY LLC	Victoria Fletcher	HUBBARD	victoria.fletcher@muddybootcontracting.com	254-229-7524	Land management, clearing, mulching, excavation, grading, mowing and shredding, hay baling, dirt work, foundation drainage, and metal buildings.	WO	F	Yes	Yes
1464856048100	MUNIZ & RODRIGUEZ INVESTMENTS LLC DBA	Robert Muniz	BRYAN	rmuniz@bigsolutionsconcrete.com	979-595-5820	Foundation Slabs, Sidewalks, Concrete Paving, Retaining Walls, & Tilt Walls.	HI	M	No	Yes
1470957150000	Madero Engineers & Architects, LLC	Frank Madero	Houston	frank@madero.net	281-610-0367	Engineering Consulting; Program/Project/ Construction Mgmt; Rehab & Improvement of Infrastructures/Engineering Services, General Management Consulting Services & Project Management/Repair of Metal and Concrete Structures/Coating/ FRP Design Calculations	HI	M	No	Yes
1834023697700	Meyson, LLC	Randall Thompson	Terrell	randall@meysonllc.com	940-442-3919	We install and repair water, sewer, storm main, and manholes. Demolition, and concrete installation	BL	M	No	Yes
1204596978400	N.A.E. ENTERPRISES, INC.	Pres Chantal Dauenhauer	FT WORTH	ce.dauen@naecontracting.com	817-220-2200	General Contracting	WO	F	No	Yes
1383806059100	NECHEMYA CONSTRUCTION	Principal - Daleth Johnson	NORTH RICHLAND HIL	daleth@nechemyasolutions.com	214-274-0750	Design/Build - collaborative architectural services - construction administration - General Contracting	BL	M	Yes	Yes
1474493752600	NEXLEGACY LLC	Kendrick Whittington	HUTTO	kendrick@nexlegacyconstruction.com	512-426-9688	We are a general construction and technology solutions company. We offer residential and commercial building construction services along with technolo	BL	M	No	Yes
1473302832900	NFA ENVIRONMENTAL, LLC	chris haugstad	BULVERDE	chris.haugstad@nfaenvironmental.com	702-353-5729	environmental consulting, soil and groundwater remediation, environmental site assessments and impact studies, waste management, emergency spill response and abatement, mobile onsite water treatment with activated carbon, skimming of oil/water separators	DV	M	No	Yes
1473035911500	NOBLE TEXAS BUILDERS, LLC	Christine Blouch	La Feria	juan.delgado@nobletx.net	956-520-8183	General Contractor, Construction Manager, Design Build, Building Maintenance	HI	M	No	Yes
1202089172200	NORTH AMERICAN COMMERCIAL	Partner / Lynn Dunlap	DALLAS	lynn@naccolp.com	972-620-9975	General contracting specializing in interior finishout and all related trades	WO	F	No	Yes
1752692487700	NOUVEAU TECHNOLOGY SERVICES, LP.	Brian Beiling	CARROLLTON	bbeiling@ntslp.com	972-484-5077	Voice & data cabling, fiber optic cabling, Job Order Contracting	WO	F	Yes	Yes
1452910724600	NOVIUM GROUP LLC	Managing Mbr/Tyler Walbridge	AUSTIN	tylerw@noviumgroup.net	512-767-2478	General contractor, commercial building remodels, exterior site work, interior remodel, HVAC, Electrical, Sheetrock, framing, texture and paint, flooring, ceiling, roofing	HI	M	No	Yes
1833032565700	Native Consolidated Management LLC	John Lee	Richardson	admin@native-construction.com	832-469-5579	Consulting Services, General Contracting, Trade Construction, Security, Electrical, Painting, Framing, Demolitions, Landscaping, Drywall, Flooring	AI	M	Yes	Yes

1465498237100	Occupational Safety Solutions	Bradford Holman	Elgin	ossolutions@outlook.com	512-686-1381	OSS provides safety management consulting in the areas (1) OSHA 10/30 hour Training and safety awareness i.e. Flagger, CPR, Development of written safety programs, conducting site safety audits, air monitoring and sale of safety supplies.	BL	M	No	Yes
1270963759400	OnSite Contracting, LLC	Benny Ximenez	San Antonio	lois@onsite-contracting.com	210-472-2345	Building Construction, Site Construction, Rehab, Concrete, Steel, Renovations	HI	M	No	Yes
1831112304800	Oppie's Topsoil, LLC.	Megan Cortinas	Bryan	megan.cortinas310@gmail.com	979-822-5570		HI	M	No	Yes
1273358266700	PANDO CONSTRUCTION, LLC	Robert Pando	MIDLAND	pando432@gmail.com	432-425-5566	Oilfield Construction, Commercial Construction, Excavation, Pads, Roads, Demolition, Custom Material Crushing TXDOT approved, Concrete & Asphalt Paving, Concrete Tear Out, Material Hauling, Site work, Earthwork, All Heavy Machinery Construction	HI	F	Yes	Yes
1465065270500	PARK CONSTRUCTION & BUILDING MAINTENANCE	Nathan Park	ROYSE CITY	megan@parkcbm.com	972-636-2260	We are a general contractor and all around commercial building maintenance contractor. We do but are not limited to concrete, masonry, erosion control, remodels, plumbing, electrical, cleaning, grading, debris removal and clean up, demolition.	AI	M	No	Yes
1852234724600	PARKER CONCRETE	Lance Marrs	WICHITA FALLS	parkerconcrete3@gmail.com	940-267-0063		DV	M	No	Yes
1833063256500	PBS CONSTRUCTION, LLC.	Paula Salvaggio	FARMERSVILLE	info@pbs-construction.com	972-775-0897	PBS provides a wide array of construction needs. Turn-key new construction, renovations, specialty construction, demolition, planning, flatwork, landscape and hardscape, environmental.	WO	F	Yes	Yes
1710966286000	PERPETUAL DEVELOPMENT, LLC	Ahmad R. Drumgo	HOUSTON	admin@perpetualhomes.com	713-742-3336	General Contracting Firm ,Specializing in Demolition project,Buildout Building maintenance, management and consulting.	BL	M	Yes	Yes
1331135164000	PIATRA INC.	Mirela Glass	Austin	mglass@piatrinc.com	512-299-0404	Company offering general construction services with a focus on concrete, masonry, welding and structural metal structures and fencing projects.	WO	F	No	Yes
1760660283100	PILGRIM CONTRACTORS, INC.	Pres./Elise Carranza	PINEHURST	elise.carranza@pilgrimcontractorsinc.com	281-356-7647	Commercial and Residential construction.	HI	F	No	Yes
1201111385400	PILLAR AND STRONG INC.	OwnerLee Olawale	HOUSTON	lee@pillarandstrong.com	713-780-3100	Construction.	BL	M	No	Yes
1752404077500	PINTO CONSTRUCTION CO., INC.	Theresa Ann Ainsworth	NACOGDOCHES	chinton0810@yahoo.com	936-569-6155	HEAVY HWY CONSTRUCTION	WO	F	Yes	Yes
1742513704300	PITTS CONSTRUCTION, INC.	PresMary Schneider Pitts	AUSTIN	pittsconstructioninc@gmail.com	512-327-4040	Underground Utilities - wet and dry.	WO	F	No	Yes
1205845549900	POST L GROUP, LLC.	Jeff Postell	FORT WORTH	jeff@postlgroup.com	682-312-7888	Comprehensive construction company providing General Contracting, Building Design, Construction Management and pre-construction services.	BL	M	Yes	Yes
1203013918700	POTERE CONSTRUCTION LLC	OLGA SHARON DOUGLAS	FORT WORTH	sdouglas@potereconstruction.com	817-429-2443	CONCRETE COMMERCIAL, HEAVY HWY, Wall CONSTRUCTION	BL	F	Yes	Yes
1202900979700	PRECISION SITE SERVICES, LLC	Delaina Lewis	SPRING	dlewis@precisionsiteservices.com	281-580-1432	Dirt, Utility, Concrete, Drywall Subcontractor	WO	F	No	Yes
1811449434900	PRIME M&C INC	Marcus Cruz	ALICE	ccruz@pmc303.com	361-664-5551	General Construction services and building maintenance.	HI	F	No	Yes
1455204194000	PROTECT TRANSPORTATION, LLC	A. Kirsten Cameron	HALTOM CITY	akcameron@protectusa.net	817-589-9005	Transportation of hazardous and non hazardous material	WO	F	Yes	Yes
1473553089200	Packard Building Services, LLC	Keenan Packard	Grand Prairie	kpackard@packardservice.com	682-401-7705	General Contracting; Construction Management	BL	M	No	Yes
1473869632800	Precision Power Solutions	Cesar Ramirez	Houston	cesar.ramirez@precisionpower.solutions	832-860-8067	Electrical Contractors Including Data Communication, Cabling, Electrical Signage Installation, & Energy Management Systems Services	HI	M	No	Yes
1203109350800	Prestique, Inc.	Lisa Cunningham	Dayton	lisa@rangerroof.com	281-328-3678	General Construction for commercial, industrial and residential customers	WO	F	No	Yes
1208203273600	Prim Construction, LLC	Elizabeth Prim	FORT WORTH	bprim@primconstruction.com	817-885-7851	PRIM is a full-service construction management firm that builds on rock solid relationships with both clients and partners to ensure every piece of your project falls perfectly into place. PRIM is transforming how people view the construction management	WO	F	No	Yes
1461542641900	Q Recycling & Construction Services, Inc	Murtaza Badri	Cypress	info@qrecycling.com	832-263-0152	Q Recycling & Construction Services is a demolition and earth work contractor.	AS	M	Yes	Yes
1020720408100	QUALITY INNOVATIONS, INC.	President / Michele L Morgan	BOERNE	Michele@QJ2LLC.com	281-705-8709	GENERAL CONTRACTOR AND MATERIAL SUPPLIER FOR CONSTRUCTION PROJECTS	WO	F	No	Yes
1742905554800	QUEST CONTRACTING, INC.	PRESIDENT/JOSE GALLEGOS	EL PASO	j.gallegos@questcontracting.net	915-857-2733	DIRT & PAVING CONTRACTOR	HI	M	No	Yes
1474017716800	R & D DIRT WORKS AND CONSTRUCTION	Patrick Ferrand	PASADENA	rddirtworkspatrick@gmail.com	281-891-0496	Land Development,Site Development,Lime Stabilization,Concrete Flat Work, Site Grading, Demolition,Commercial Building Pads, Residential Building Pads,Parking Lots,Lime Slurry Distribution,Fly-Ash Distribution,Storm Water Drainage	HI	M	No	Yes
1453833434400	R.T. CONSTRUCTION	Arnoldo Gomez	HUMBLE	gomezrtconstruction@gmail.com	713-298-2989	Commercial and Residential New Developments, Remodeling, Renovations, Sidewalks, Driveways, Roofing, Flooring, Walls, Painting, Bathrooms, Kitchens, Carpentry	BL	M	No	Yes
1815028277200	R3 RESOURCES, LLC	Rachelle Webster	CYPRESS	shelly.r3texas@gmail.com	832-439-1232	Construction and Remediation Consulting Services with an Environmental Focus	WO	F	Yes	Yes
1262775390301	RACHEL BYRANT CO	Rachel Rawlings	GALVESTON	rachelbryantco@gmail.com	855-504-5500	Our Commercial division offers innovative solutions for public & private sectors- Interior build- out & Alterations as general contractor and/or Subcontractor.	WO	F	No	Yes

1843866436100	RAM TELECOM LLC	layal Assi	HOUSTON	layal@Ramtelecomandconstruction.com	832-620-0087	residential commercial and industrial maintenance & repair.	AS	F	Yes	Yes
1852247494100	RAVA Construction, LLC	Jaclyn Ladewski	Houston	atul@ravausa.com	832-304-0060	Building construction general contracting construction management and consulting	AS	M	No	Yes
1461506604100	REBAR REINFORCEMENT PLACERS, LLC	Maria Lomeli	HOUSTON	andresp@rrplacers.com	281-484-3265	We specialize in the installation of concrete, reinforcing steel, and post-tension cables in Texas.	HI	M	No	Yes
1803164114700	REID'S ESTIMATING AND CONTRACTING LLC	Reid's Estimating and Contracting LLC	SUGAR LAND	breid@reidsestimatingllc.com	303-261-2089	Reid's Estimating and Contracting performs and bids on: Waterproofing applications to commercial and residential builds, Remote Project management services, and single family home construction	BL	M	No	Yes
1800345488300	REMOLINO, INC.	OwnerJoel L Garcia	Mustang Ridge	Joel@bcstustin.com	512-454-9090	Commercial Turn-key Concrete Structures Including Multi-Story, Schools, Banks, Retail Stores , Medical Facilities, Site Improvements	HI	M	No	Yes
1475120744100	RGON CORPORATION	Roger Gonzales Jr	BUDA	rgon0622@gmail.com	316-443-4467	General Construction, Fencing, landscaping	HI	M	Yes	Yes
1854004124300	RIGHT ACRES, LLC	Christine Weishuhn	HOCKLEY	cweishuhn@therightacres.com	281-505-5175	Services include, but are not limited to, right of way maintenance, large acreage mowing, vegetation management, grounds maintenance, and landscaping services.	WO	F	No	Yes
1814439770200	RIGHT CHOICE DEVELOPMENT AND CONSTRUCTIO	Danielle Wright	KATY	danielle@rightchoicedev.com	832-567-9648	Right Choice Development & Construction is a female-owned, Houston based commercial general contractor that specializes in corporate interior and exterior remodels and build-outs, retail spaces, shopping centers, industrial spaces and office buildings.	WO	F	Yes	Yes
1432014240000	RISE RESIDENTIAL CONSTRUCTION, LP	Melissa Fisher	DALLAS	Mfisher@rise-residential.com	972-701-5558	Our principal line of business includes multifamily residential rehabilitation construction projects. We have been in business since 2003, and our principals have over 35 years of experience and 9,000 units on the ground.	WO	F	No	Yes
1742731913600	RML HAULING & MILLING, INC.	MINERVA G. JUAREZ	BROWNSVILLE	rmllinc3293@gmail.com	956-546-3750	Site Preparation Contractors, Storm sewer construction, Boring, drilling, and milling machine combinations, Hauling	WO	F	No	Yes
1742819524600	RODRIGUEZ BARR INC.	Maricela Rodriguez Barr	AUSTIN	office@thebarrcompany.com	512-474-4222	CONSTRUCTION/PROGRAM MANAGEMENT; ARCHITECT 054075	HI	F	No	Yes
1202134818500	ROGERS CONSTRUCTION, LLC	RODNEY B. ROGERS	WINONA	rogersconstruct@aol.com	903-877-2054	NEW HOME CONSTRUCTION & REPAIR	BL	M	No	Yes
1862247423900	RS&G PROPERTIES LLC	Maria A. Rosado Lightfoot	SAN ANTONIO	maria.a.lightfoot@gmail.com	706-617-7459	Real Estate and construction	BL	F	Yes	Yes
1465218100000	RUCOBA & MAYA CONSTRUCTION, LLC	Rodolfo Rucoba	KYLE	florencio@rmconstructiongroup.com	832-867-6673	Special Trade Construction	HI	M	No	Yes
1834189431100	RYMARH CORPORATION	Maria Hobbs	LEANDER	rymarhcorporation@gmail.com	512-986-9625	Construction General Contractor Construction Management	HI	F	Yes	Yes
1471549646000	Real Estate Chasers, LLC	travis louie	San Antonio	Travis@RECONSTRUCTION.BIZ	210-563-9169		AS	M	No	Yes
1760567369200	Redwine Construction Co. (Redwine Enterp	REDWINE, PATRICIA KPAT	NEDERLAND	TREDWINDE@GT.RR.COM	409-722-8373	Dirt pit, transportation, earth work, and land development	WO	F	No	Yes
1260477105000	Reim Construction, Inc.	Miguel A Ramos Miguel A Ramos	MISSION	miguelfr@reimconstruction.com	956-537-1030	Street Improvements, water and sanitary sewer lines,storm sewer lines,concrete work (airports,etc.) asphalt work.	HI	M	No	Yes
1844335229100	River Line Contracting, LLC	Roberto Quintanilla	McAllen	robert@riverlinecontracting.com	956-358-4041	General Contracting / Construction Services, and Construction Management	HI	M	No	Yes
1061767760300	Rockin Q Construction LLC	Kitty-Sue Quinn	FREDERICKSBURG	Kitty@RockinQ.com	512-392-0627	UNDERGROUND UTILITY INSTALLATION AND REPAIR	WO	F	No	Yes
1863828997700	Rockriver Development LLC	Marc Flores	Houston	marc@rockriverdev.com	832-819-9905		HI	M	No	Yes
1831424454400	S-CON CONSTRUCTION, LLC	Ashley Villalobos	CORPUS CHRISTI	ashley@s-conconstruction.com	361-299-5161	General Construction, site work, trenching, building renovations.	HI	M	No	Yes
1760322250000	S.S. CONSTRUCTORS, INC.	Amy Schovajsa	HUMBLE	Tsc909@aol.com	281-441-8096	Underground Utilities to include Excavation, Boring Saw Cutting, and Removal and Replacement of Concrete/Asphalt	WO	F	No	Yes
1274523579100	SABINE INDUSTRIAL SOLUTIONS, LLC	Kari Potter	CENTER POINT	kari@potter-construction.com	830-285-2684	Our services include but are not limited to: Heavy Equipment & Excavation Work, Civil Work, Oil Field Site Remediation Work, Environmental Clean Up & Waste Disposal, Demolition and Debris Removal	WO	F	Yes	Yes
1262941288800	SAMES, INC.	Samuel D. Maldonado, P.E., RPLS	MCALLEN	saul@samengineering-surveying.com	956-702-8880	Civil Engineering, Consulting & Design, Surveying, Land Development, General Construction, & Construction Management.	HI	M	No	Yes
1300625973600	SARVICUS LLC	MARC PACKARD	HOUSTON	marc.packard@sarvicus.com	713-489-5380	Sarvicus focuses on telecommunications and information technology installations, repair, maintenance and service of audio, video, networking, security, alarm, access control, structured cabling system. We also provide OSP Construction Services.	DV	M	Yes	Yes
1760192206900	SEPARATION SYSTEMS CONSULTANTS, INC.	Lisa Landers	HOUSTON	ssci@sscienvironmental.com	281-486-1943	Engineering, Construction, & Enviro Services: Fuel System Design-Install-Removal-Closure & Remed; Site Assessments; SPCC Plans; Asbestos; Lead Paint; Haz Waste; NEPA; Compliance & Permit; Project Oversight; Wetlands; Detention/Stormwater	WO	F	Yes	Yes

1900119453900	SERCO CONSTRUCTION GROUP, LTD	President/CEO / Serge Francois	DALLAS	cfrancois@sercoconstruction.com	214-948-0159	Serco Construction Group, Ltd. is a privately held DBE, MBE and HUB certified firm that offers a wide range of heavy civil construction projects in both the horizontal and structural concrete, and mass and structural excavation industries.	BL	M	No	Yes
1205217354400	SKE Construction, LLC	Shelly A. Eberhart	Cypress	shelly@ske1.net	281-585-4100	General contractor. Specializing in Design/build JOC. Experienced Utility Rehab/Install, Concrete replace, Fencing, Site Restoration	AI	F	No	Yes
1881014561700	SKO Elite Repair LLC	Aldo Davila	San Juan	hector@skoelite.org	956-739-0810	General Contracting, Building Construction & Facility Maintenance	HI	M	Yes	Yes
1821441463500	SLR BUILDING CONTRACTORS, LLC	Stephanie L. Renteria	EDINBURG	S.RENTERIA@SLRBC.COM	956-383-8194	Commercial General Contractor, Roofing Contractor, Insulation Contractor, Damp Proofing Contractor	HI	F	Yes	Yes
1752859199700	SMR CONSTRUCTION INC.	Samar Bashir	Richardson	samar@smrconstructioninc.com	972-231-7272	CONCRETE CONSTRUCTION, BUILDING ADDITION & RENOVATION.	AS	M	No	Yes
1205476566900	SPIRE CONSULTING GROUP, LLC	Anthony Gonzales	AUSTIN	proposals@spirecg.com	512-637-0845	Multi-disciplined construction engineering consulting firm.	HI	M	No	Yes
1331034875300	SSP INDUSTRIES, LP	Melissa Miller	KILLEEN	mmiller@ssp-ind.com	254-699-2115	COMMERICAL PLUMBING, PIPELINE UTILITIES & ROAD BORING	WO	F	No	Yes
1721590394300	STATEWIDE SERVICES, INC.	Camell Alison Jr.	HOUSTON	mel@statewideservicesinc.net	713-864-3368	Land Clearing, Tree Removal Tree Trimming, Hauling, Debris, Concrete Contractor, Manhole Work and Excavation, Storm Sewer Installation, Sanitary Sewer Installation, & Waterline Installation, Supplier of Water Treatment Equipment	BL	M	No	Yes
1450571287800	SUPERIOR AUTOMATIC FIRE SYSTEM, LLC	DANIEL A HYTCHE	HOUSTON	superiorautomatic@gmail.com	713-413-9655	FIRE SPRINKLER INSTALLATION, SERVICE, INSPECTIONS	BL	M	No	Yes
1474762506000	SYNERGY MACHINE, LLC	OSCAR CRUZ	HOUSTON	OCRUZ@SYNERGYMACHINE.LLC.COM	832-641-3272	Manufacturing precision machined part such as foundation micro piles, helical Piles, turned products, fabricated pipe and welding equipment or tools. Structural steel casing. Service, asphalt and concrete repairs.	HI	M	No	Yes
1452850105000	SYNERGY PROJECT CONTRACTORS, INC.	Luis Luna	EL PASO	LLUNA@SPC-PM.COM	915-487-4347	Heavy Highway Construction and Maintenance, General Contractors; IT Infrastructure/Cabling; Physical Security Systems (CCTV/Access Control) TX License B17681	HI	M	Yes	Yes
1260331391200	Seneca Construction Management, LLC	GWENDOLYN MAUPIN	KILLEEN	gmaupin@seneca-construction.com	254-394-9303	I am a women owned and operated business. In June of this year I have successfully operated this construction company. I'm very proud of what I have built. It has not been easy to run a women ran company in this man dominated industry. I also have mostly	AI	F	No	Yes
1270991760800	T & T EARTH MOVERS, INC.	Terry Suarez	SEMINOLE	phillip@earth-movers.net	432-955-0558	Specialize in oilfield heavy dirt construction. Services also include residential and business demolition, preparation of properties, asphalt paving, and underground utilities. Licensed for residential OSSF installation.	HI	M	Yes	Yes
1821119816500	TAJE AND CO., LLC	Joshua Jackson	CROSBY	taje.and.co@gmail.com	281-764-5021	Taje and Co also does business as Meteor Midstream Services which offers Pre construction ground work, in grubbing and clearing, earth moving and right of way maintenance.	BL	M	No	Yes
1853209898700	TERRA FUERTE CONSTRUCTION LLC	Rolando Leal	ALAMO	admin@terrafuerte.com	956-685-5252	General Contracting, Preconstruction, Construction, Post Construction	HI	M	Yes	Yes
1824979867100	TEXAS DEWATERING, LLC	Carl Fromen	HOUSTON	info@texasdewatering.com	936-246-3016	Repair and Rehabilitation of Bayous and Canals, Restoration of Dredging Placement Areas	HI	M	Yes	Yes
1203760837400	TEXAS DRILLIT LLC	Dane Owens Vice President	CLEBURNE	texasdrillit@yahoo.com	817-556-0250	Horizontal Directional Drilling and Pipeline Construction	WO	F	No	Yes
1455268192700	TEXAS GLOBAL CONSTRUCTION, INC.	Denise Schopfer	DALLAS	denise@txgcinc.com	214-357-6404	TGC, Inc. Provides construction renovation and maintenance services. Our Services includes high voltage electrical work, Roofing, Flooring, painting, Concrete Work, Metal work and fencing work	WO	F	Yes	Yes
1921814372500	TEXAS PATRIOT CONTRACTING LLC	Nicholas Lesko	ROUND ROCK	txpatcont@gmail.com	737-226-8825	General Construction, sitework, demolition, concrete, carpentry, drywall, painting, landscaping services	DV	M	Yes	Yes
1742507983100	THE 5125 COMPANY	Contact Person	EDINBURG	PE5125@AOL.COM	956-583-5125	Underground Utility Contractor	HI	F	No	Yes
1883222334300	THE ASSET CLUB LLC	Derrick Newby	FORT WORTH	theassetclubllc@gmail.com	817-896-5775	We specialize in building construction and paving services, The company's core competencies include project management, engineering, procurement, and construction, as well as the ability to deliver high-quality results on time and within budget.	BL	M	Yes	Yes
1851197398600	THE COLONNA GROUP, LLC	Sterling Dodd	HOUSTON	sterling@thecolonnagroup.com	817-449-4609	The Colonna Group specializes in Outdoor Hospitality and RV Park Management.	HI	M	No	Yes
1205988228700	THE FENCE LADY, INC.	Pres./Rebecca Dean	BOERNE	Rdean1473@aol.com	830-822-1822	General Construction.	WO	F	No	Yes
1203114535700	THE SABINAL GROUP, L.L.C.	Daniel Benavidez	San Antonio	danny@sabinal-group.com	210-226-3400	Construction	HI	M	No	Yes
1208763967500	THR Enterprises, Inc.	Samuel Eaton	Houston	samuel.eaton@jngreenteam.com	832-279-9856	Construction Management, Waste Management Services, Business Consulting, and Property Management/Street Sweeping and Graffiti Removal	BL	M	No	Yes
1815458994100	TIA FACILITY SERVICES LLC	Lorenza Guerrero	EL PASO	lguerrero@tialc.us	915-433-7881	General Construction, Janitorial Services, Grounds Maintenance	HI	F	Yes	Yes
1223866927400	TIERRA FIRME CONSTRUCTION, INC.	ADRIAN RUIZ	EL PASO	tierrafirmeco@aol.com	915-881-0200	STRUCTURAL CONCRETE AND SITE PREPARATION	HI	M	No	Yes

1455568297100	TITAN MILLING INC.	Sara Allen	JOHNSON CITY	sara@titanmillinginc.com	830-833-0474	Asphalt paving, seal coat, city street planning, utility excavation & installation, hard rock milling, retention ponds	AI	F	No	Yes
1460536662500	TM SOURCE BUILDING GROUP, INCORPORATED	Laurie Smithson	FORT WORTH	tmapp@sourcebuild.net	817-355-9321	Commercial General contractor and construction manager who focuses on building construction in healthcare, education, aviation, county, municipal, federal and private clients.	BL	M	No	Yes
1270398323400	TOP GUN TOP DOG, INC.	Sec and VP Mark K Tafel	LEONARD	mark@topguntopdog.com	469-744-5900	Excavation, Land Clearing, Demolition, Disaster Recovery and site preparation.	WO	F	Yes	Yes
1205948178300	TOPSIDE CONTRACTING, LLC	Jerry Fernandez	SAN ANTONIO	jerry.fernandez@topsidecontracting.com	210-438-1030	Roofing contractors and Sheet metal work (except stampings) manufacturing.	HI	M	Yes	Yes
1760331150100	TRECO ENTERPRISES, INC.	Edward Trevino	SAN ANTONIO	bthompson@trecotx.com	210-377-3131	General contractor performing residential and commercial building renovations and new construction as well as tree trimming/removal services and pressure washing services.	HI	M	No	Yes
1842737421200	TREG EROSION CONTROL SPECIALISTS, LLC	Tiffany Rawls	FORT WORTH	TregErosion@protonmail.com	817-592-6280	Earth Retention Contractor	WO	F	No	Yes
1760775331000	TRINI CONSTRUCTION BUILDER LLC	Reginald Worlds	AUSTIN	INFO@TRINICONSTRUCTIONBUILDER.COM	512-506-1310	Subcontracting & General Construction opportunities	BL	M	No	Yes
1208343025100	TRIUN, LLC	Edward R. De La Garza	SAN ANTONIO	EDELGARZA@TRIUNCO.COM	210-572-4900	CIVIL ENGINEERING SERVICES SPECIALIZING IN TRANSPORTATION, COMMERCIAL/RESIDENTIAL LAND DEVELOPMENT AND PUBLIC WORKS. Surveying Services and General Construction	HI	M	No	Yes
1522374490300	Tec Excavation, Inc.	President - Twyla K Clutter	MIDLAND	tkc@teceexcavation.com	432-687-5346	MINOR STRUCTURES; UNDERGROUND AND UTILITY WORK 14302\$	WO	F	No	Yes
1273712941600	Texas Velocity Enterprises LLC	Darren Richardson	San Antonio	drichardson@poweredbyvelocity.com	210-251-3466	General contractor. Construction projects to include roofing, roads and interior/exterior work.	DV	M	No	Yes
1455366440100	TexasChile Inc	Pia Van Ryder	KINGWOOD	info@txchile.com	713-397-0230	Commercial Construction; Parking Lots, Driveways, Underground Pipes (Utilities), Sidewalks, and Demolition Services/Storm Sewer, Waterline, Sanitary L	HI	M	No	Yes
1751832175100	Theford Construction Company Inc	Wilma Theford	TYLER	theford_const@tyler.net	903-561-1584	Underground and overhead electrical contractor for local electric delivery companies. Also work for large companies that have their own primary meteri	WO	F	No	Yes
1462540571800	UMD ENERGY SOLUTIONS	Mia Ngo	HOUSTON	payroll@umdenergysolutions.com	281-895-3210	Construction concrete, building, commercial remodel, Services in Talent and Acquisitions, IT related services (Infrastructure, Platform, Cloud),	AS	M	No	Yes
1364777495200	Underground Water Solutions Company, Inc	Zoila Benitez	Elgin	zoila@uwscsco.net	512-278-9333	Water and Sewer Line and Related Structures Construction	HI	F	No	Yes
1753044081100	V & V SERVICES, INC.	Linda Darden Verhovshek	CARROLLTON	VANDVENTERPRISES@TX.RR.COM	972-492-7613	Environmental Support Services - Erosion Control Services - Storm Water Management Services - Contract Management Services - Purchasing Agent Materials Supplier - Project Management/Scheduling/Logistics - Transportation Battery Supplier	BL	F	No	Yes
1274809925100	VAQUERO COMMERCIAL, INC.	Director/Audon Aguillon	AUSTIN	audon@vaquerogrp.com	512-388-7400	Landscape & Irrigation development and management.	HI	M	No	Yes
1270962229900	VCI BUILDERS, INC.	Jose Luis Arredondo, Jr	MISSION	joe@vcibuilders.com	956-627-3101	General contractor with experience in break ground, excavation, foundation, utilities, framing, roofing, electrical, insulation, drywall, flooring/tile, painting, cabinetry, finish outs, repair/remodeling work to existing structures.	HI	M	No	Yes
1811417143400	VERO CONSTRUCTION, LLC	Veronica Mclemore	ARLINGTON	veronicam@pavecon.com	214-876-9357	Construction maintenance on concrete and asphalt work. Along with stripping and sealcoat. New concrete and asphalt construction	AI	M	No	Yes
1841875969400	VOSBURG WELSH LLC	Operations Manager / Matthew James Welsh	FAIRVIEW	matthew.welsh@vosburgwelsh.com	972-430-8421	Our company provides private utility location and Subsurface Utility Engineering (SUE) services. utility coordination, ground penetrating radar, concrete scanning.	DV	M	Yes	Yes
1203879401700	Vertex Contractors, LLC	Erika R Ruiz	EL PASO	erruiz@vertexcontractors.net	915-591-6170	Heavy construction other than building construction and a special kind of trade construction. Selective demolition, earthwork, storm drain, underground utilities, site concrete and building concrete.	HI	F	No	Yes
1822235487200	Vetra Global Services, LLC	DAISY WILTCHER	HOUSTON	BD-Inquiry@VETRAGLOBAL.COM	832-602-4222	General Contracting, Maintenance (Landscape, Mowing) Construction site clean-up, hauling, decries clean-up, minor construction/concrete, material supplier and rest area maintenance/cleanup.	BL	M	No	Yes
1760541820500	W. A. Robbins Construction Co., Inc.	Wendell A. Robbins III	Houston	wendell3@warobbinsconstruction.com	713-644-5823	Interior & Exterior Renovations, Concrete Construction, and Underground Utilities (cabling & fiber optics)	BL	M	No	Yes
1522408948000	WELCH EXCAVATION & UTILITY COMPANY, INC.	President - Janis Lee Welch	WINONA	welchexcavation@gmail.com	903-877-3528	COMMERCIAL SITEWORK, DEMOLITION, PAVING AND UTILITY WORKT	WO	F	Yes	Yes
1810967715500	WESSON CONSTRUCTION SERVICES LLC	Roylins Wesson	GRAND PRAIRIE	rwesson@wessoncs.com	469-556-2580	General Contracting firm that provides Construction Project Management, budgeting, Scheduling, and consulting	BL	M	No	Yes
1752659366400	WHITE CONSTRUCTION COMPANY	President, Glinn H. White, Jr.	KERRVILLE	glinn@whiteconstructioncompany.com	830-257-7477	General Contractor serving the Texas Hill Country.	AI	M	Yes	Yes

1263917760400	WILSON BUILDING SERVICES, INC.	Wendell A. Wilson	STAFFORD	info@wilsonbuildingservice.com	281-780-0700	Construction maintenance for the private and public sector. Provide support medium-sized commercial building, municipal, transportation infrastructure, industrial building projects and maintenance services for master planned communities.	BL	M	Yes	Yes
1851782407600	WTX CONSTRUCTION LLC		El Paso	wtxconstruction_llc@yahoo.com	915-218-9869	Rockwalls, retaining walls, landscaping, groundskeeping, excavation & grading.	HI	M	No	Yes
1454044771200	YUCCA CONTRACTING	Maggie Vaquera	EL PASO	israel@yuccaconstruction.com	915-525-7135	Painting, insulation, plumbing, electrical, demolitions, flooring, roofing, suspending ceilings, door/window frames all types,concrete slabs, sidewalks,footings asphalt excavation, field and shop welding, field and shop steel fabrication	HI	M	Yes	Yes
1571241153500	ZTEX CONSTRUCTION, INC.	Joaquin Royo	EL PASO	AR@ZTEXCONSTRUCTION.COM	915-591-6900	Earthwork;Paving; Utility line construction, Water & Sewer line related structure and construction, Highway, Street, and Industrial building constructionn, Concrete	HI	M	No	Yes

Date : 2024/01/18 09:38:06

CMBL SUMMARY

Search Found 315 Vendors ,315 are Hubs , Includes 0 Inactive Vendors

Search Condition : SearchType=HUB's Only,Section1 Class Code=912,Section1 Item(s)=(23)

Results for HUBs for 912-44 : Excavation Services										
Vendor ID	Company Name	Contact Person	City	Email	Phone	Business Description	HUB Eligibility	HUB Gender	CMBL Stat	HUB Status
1475357271900	1DZ ENTERPRISE LLC	Debra A. Garcia	ARANSAS PASS	debbiegarc20@gmail.com	361-534-4244	Janitorial Service, Construction Cleanup, Site Preparation, Demolition, Demolition Cleanup,Paving, General Construction, Concrete Work	HI	F	No	Yes
1454338911900	2GS, LLC	HUMBERTO GARCIA JR	PENITAS	bgarcia@2gsllc.com	956-424-3414	2GS, LLC specializes in the construction of paving and underground utility lines. This includes new and existing street work and all related appurtenances for the installation of water, sewer and storm sewer lines.	HI	M	No	Yes
1461995281600	360 TXC, LLC	Tony LESTER	AUSTIN	dlester@360txc.com	512-229-6440	We provide general contracting and complete project planning and management services. Our vast project portfolio covers everything from 1,000sqft interiors and renovations to 25,000sqft+ ground-up and core-shell buildouts.	BL	F	No	Yes
1842115429700	9 Ether Global Services, LLC	Ariel Mitchell	Houston	9etherglobal@gmail.com	832-236-7497	General contracting services. Also provide the following trade services: drywall, framing, ceiling, painting, flooring, specialties, carpentry, Division 9 & 10, etc.	BL	M	No	Yes
1760648286100	A & A Cable Contractors, Inc.	Andres Cruz	Houston	afores@aacable.com	281-469-2888	Telecommunication Underground Cable Laying (Voice, Data and Fiber Optics)	HI	M	No	Yes
1474951661400	A STATUS CONSTRUCTION	Marisa Rodriguez	FRIENDSWOOD	mr@indicstruction.com	713-859-4658	General Contractor	HI	F	Yes	Yes
1832288563500	A&B EXCAVATION, LLC	Sravan Eadara	FORT WORTH	estimating@abexcavation.com	469-543-7151	Demolition, Storm drainage, Pond and lake development and dredging, Driveways and parking lots, Disaster clean up	WO	F	Yes	Yes
1742971115700	A.C. CONTRACTING SERVICE, L.L.C.	Ptnr/ARMANDO CONTRERAS	MISSION	lou@rgv.rr.com	956-683-5115	EXCAVATION FOR UNDERGROUND buried CABLE and other UTILITIES.	HI	F	No	Yes
1593827267900	ACE CO CONSTRUCTION, LLC	Eric Gebhart	San Antonio	bettydrennan@acecosa.com	210-494-2338	Parking lot marking and line painting, Parking lot paving and sealing and Parking lot cleaning (e.g., power sweeping, washing) services.	HI	F	No	Yes
1752579021200	ACE CONTRACTORS, INC	ROYALENE MCEACHERN	SAN AUGUSTINE	acecontractors44@gmail.com	936-275-9450	mowing, guardrail,culverts,repair work, dirt hauling,equipment hauling,excavation,track-hoe, bulldozer work, fence install/repair,guardrail insulation and repair,portable potty rentals, small tree trimming and stump grinding	WO	F	No	Yes
1460532886400	ACG Contractors LLC	Victor Alvarez	Houston	monica@acggc.com	281-416-4333	Whether a small or a large scale project, ACG's construction services are delivered within our culture of integrity and projects completed on time and within budget.	HI	F	No	Yes
1752966405800	ACUMEN ENTERPRISES, INC.	Wayne Boyter	DESOTO	wayne@acumen-enterprises.com	972-572-0701	Mechanical HVAC & plumbing contractor, mechanical insulation, & general construction	AI	M	Yes	Yes
1931788048200	ADCOM Enterprises LLC	Carlos Montfort	Brownsville	carlosmontfort95@gmail.com	956-525-3756	Construction and contracting services	HI	M	Yes	Yes
1465359949900	AGGIELAND CONSTRUCTION, LTD.	Britt Jones	WELLBORN	britt.jones@aggielandconstruction.com	979-393-0080	Any general contracting that involves new, old, and remodeling construction.	WO	F	Yes	Yes
1200334965600	ALAMO ENVIRONMENTAL, INC. DBA ALAMO 1	President / J. Alex Salas	SAN ANTONIO	jsoto@alamo1.com	210-404-1220	Full service contractor providing general construction, special trade construction, demolition, remediation, abatement, hazardous material disposal, emergency response services, spill response services, and commercial waste services.	HI	M	Yes	Yes
1462061957800	ALL MATERIALS CONSTRUCTION, LLC	Lakeisha Brown	NEW BRAUNFELS	allmaterialsconstruction@gmail.com	830-515-6623	we are a general contractor in building also roads and bridges.Lawn maintenance and Janitorial Cleaning, striping paving,painting fencing,concrete,roofing,floors	BL	F	No	Yes
1455294324400	ALPHA ASPHALT AND PARKING LOT CONTRACTOR	Iliana Chavez	EL PASO	iliana@alphapavingep.com	915-667-8303	Alpha Asphalt provides all types of parking lot repairs from start to end. We do Seal Coating, Striping, Crack Fill, and Paving. We also do concrete sidewalks, curb and gutters, and concrete pads.	HI	M	Yes	Yes
1463084640100	AMP CONSTRUCTORS, LLC	Amy Morales	AUSTIN	amy@moralesdevelopment.com	512-709-9610	Building Construction, including General Contractors and Operative Builders, Civil construction to include water & waste water utilities, site prep, silt fence	HI	F	No	Yes
1742740609900	AMSTAR, INC.	Mary Flores	San Antonio	tflores@amstarincgc.com	210-927-5705	Multifamily building construction general contractors, Construction management, industrial building (except warehouses), Addition, alteration and renovation general contractors, commercial and institutional building and Roofing contractors.	HI	M	No	Yes
1814101414400	ANDCO, LLC	Cory Anderson	CLEVELAND	manderson@andcollc.net	936-402-4666	dirt work, land clearing	AI	M	Yes	Yes
1853004000700	ANVIL ENTERPRISES INC.	DONNA NAYLOR	BOERNE	DONNAN.ANVIL@GMAIL.COM	210-727-3987	CONSTRUCTION, REPAIRS AND MISCELLANEOUS JOB REQUESTS	WO	F	No	Yes
1752902529200	AOC ENVIRONMENTAL, INC.	Matt Birkhead	WICHITA FALLS	customerservice@aocenviro.net	940-692-8989	Asbestos Abatement/Special Construction/Civil Construction. General Contractor.	HI	F	Yes	Yes
1760359965900	APOLLO ENVIRONMENTAL STRATEGIES, INC.	SANDY ELMS	BEAUMONT	SGELMS@APOLLOENVIRONMENTAL.COM	409-833-3330	coastal restoration and environmental contracting	WO	F	Yes	Yes
1751561172500	ARGUIJO CORPORATION	Dot Evans	ODESSA	AOSI1@HOTMAIL.COM	432-550-5650	OILFIELD MAINTENANCE & CONSTRUCTION, PIPELINING, DIRT WORK, HAULING.	HI	F	No	Yes
1205395490000	ASFI CONSTRUCTION, L.L.C.	Rachel Corbin	SANGER	rachel@asficonstruction.com	940-391-1230	ASFI Construction, LLC is a general contractor specializing in commercial and residential construction and remodeling. Our company has over 15 years experience	WO	F	No	Yes
1262197773000	ASSOCIATED CONSTRUCTION PARTNERS, LTD.	Jillian R. Simpson	BOERNE	jill@acpartners.org	210-698-8714	Heavy, Water & Wastewater Plant Construction, Utility, Electrical, General Construction	WO	F	Yes	Yes
1844445643000	ATX COMMERCIAL, LLC	KRISTIN ASHWORTH	NORTHLAKE	OFFICEATXCO@GMAIL.COM	940-390-6919	EXCAVATION COMPANY - EROSION CONTROL, EXCAVATION, EARTHWORK, DEMO., MOWING, HERBICIDE, DRAINAGE,	WO	F	Yes	Yes
1871784463500	AXE Industrial, LLC		Lakeway	karenowens.axe@outlook.com	512-970-4146		HI	F	No	Yes
1874122004200	AXIS CONSTRUCTION SERVICES, LLC	Michael Irby	ROYSE CITY	michael@axis-gc.com	972-816-3987	Residential/Non residential new construction, remodels, renovations	DV	M	Yes	Yes

1463120331300	All Works Construction Corporation	Jose Saul Cantu	ALAMO	allianceconstructionworks@aol.com	956-702-8700	Bull dozer Services, Root Plow Works, Root Rack and Stacker; Disc Work; Demolition Services; Chain Works; Back hole service; Brush Clearing; Land clearing; HI Pond Building and Dams.	HI	M	No	Yes
1050632857300	Alonso Excavation & Construction Co., In	justin hayes	San Antonio	info@alonsosevico.com	210-637-5287	Poured Concrete Foundation and Structure Contractors, Plumbing, Heating, and Air-Conditioning Contractors and Excavation contractors.	HI	M	Yes	Yes
1823006434900	Apostle Construction Enterprises, LLC	Jamie Rossler	Corpus Christi	jrossler@teamapostle.com	361-563-8021	General Construction Services including professional and consulting services, interior and exterior paint services, framing, ceiling title and grid, HVAC, plumbing, roofing and landscaping services.	WO	F	No	Yes
1473879856100	Ardent Landscape, LLC	Jason Rayes	Fort Worth	jrayes@ardentlandscape.net	817-401-1517	Irrigation Installation, repair and maintenance; Lawn maintenance; Landscaping installation and maintenance	HI	M	Yes	Yes
1752316716500	Azteca Enterprises, LLC	Kristy Smith	DALLAS	ksmith@azteca-omega.com	214-905-0612	Industrial Building Construction	HI	M	No	Yes
1752686521100	BASECOM, INC.	President / Oscar Oaxaca	FORT WORTH	oaxaca@basecominc.com	817-589-0050	Building Construction, including General Contractors And Operative Builders, Electrical Contractor	HI	M	No	Yes
1464157976900	BBC CONSTRUCTION SERVICES	Veronica Chapa	LAREDO	veronicachp@yahoo.com	210-422-5558	Construction-install;tile,carpet,vct,concrete,sheetrock and metal works.	HI	F	No	Yes
1862301257400	BEL-GRA CONSTRUCTION LLC	Jeanie James	MAGNOLIA	belgraconstruction@gmail.com	281-850-2158	General Contractor for commercial and government construction projects and developments. We can also do metal fabrication work	WO	F	No	Yes
1752567124800	BENAS ENVIRONMENTAL SERVICES,	Pres./EPHRAIM OKOTCHA	COPPELL	EO@BENAS.COM	972-393-0128	ENVIRONMENTAL ENGINEERING AND CONSULTING SERVICES, INDUSTRIAL HYGIENE SERVICES, ASBESTOS AND LEAD-BASED PAINT CONSULTANTS, INDOOR AIR QUALITY	BL	M	No	Yes
1320507295500	BLACKSTONE CONSTRUCTION INC	Junaid Noor	HOUSTON	jn@blackstoneconstruct.com	832-804-8135	General Contractors focusing on site work, development and construction of commercial properties as well as concrete paving	AS	M	No	Yes
1882794234500	BLUE'S CONSTRUCTION SERVICES	Israel Moreno	Dallas	bluesconstructionser@gmail.com	214-971-2411		HI	M	No	Yes
1861613957400	BMC LOGOPS, LLC	Michael Breito	ALEDO	mbreito@yahoo.com	817-966-0130	Erosion Control, culverts, grading, concrete demo, new concrete mowing, water transportation, large land maintenance, earth moving equipment	DV	M	No	Yes
1742939960700	BORDER DEMOLITION & ENVIRONMENTAL INC	BONNIE SOLIS	EL PASO	bonniesol@borderdemo-enviro.com	915-860-8855	Demolition and Asbestos, Lead and Mold Abatement Contractor.	HI	F	Yes	Yes
1760541174700	BOSWELL RUSTIC ROUNDUP, INC.	Pres./Beverly Boswell	MAGNOLIA	boswell1988@sbcglobal.net	281-252-7171	Commercial & Residential Construction	WO	F	No	Yes
1460808938000	BXB GROUP INCORPORATION	Pres.KATHRYN BLAKE	DECATUR	kathryn@bxbgroun.net	817-527-1292	Specialty Construction Contracting	WO	F	No	Yes
1270398287100	Brown Excavation & Utilities, LLC	Bridgett Brown	San Antonio	bridgett@beutx.com	830-931-9500	Water and Sewer Line and Related Structures Construction.	WO	F	No	Yes
1263615200600	C & C Alcoser Trucking	Cristoval Alcoser	San Antonio	alcosertrucking@sbcglobal.net	210-771-5458	Bulk mail truck transportation, contract, local; Container trucking services, local; General freight trucking, local; Motor freight carrier, general, local; Transfer (trucking) services, general freight, local; Trucking, general freight, local	HI	M	No	Yes
1202681085800	C3 ENVIRONMENTAL SPECIALTIES, LP	Dustin Pratt	SCHERTZ	dpratt@c3environmental.com	210-653-7801	Erosion Control/ Land Clearing Services.	HI	M	Yes	Yes
1260368802400	CAPPS-CAPCO CONSTRUCTION, INC.	PresRobyn E Capps	TYLER	robbyn@capps-capco.com	903-531-9670	Roadway Construction.	WO	F	Yes	Yes
1850687536000	CARBON ASSET DEVELOPER ASSOCIATES LLC	Floyd Gary Clyne	ALAMO	gary@cadaenergy.com	956-601-0016	Provide infrastructure & facility end-to-end development & retrofit of low emission & clean energy systems, heavy construction, oil & gas capital improvements, & identification of investments for greenfield energy projects. We place carbon equity to	BL	M	Yes	Yes
1752918306700	CARCON INDUSTRIES & CONSTRUCTION, LLC	Arcilia Acosta	DALLAS	aacosta@carconindustries.com	214-352-8515	GENERAL CONSTRUCTION SERVICES-CONSTRUCTION PRODUCTS PURCHASING-TELECOMMUNICATIONS SERVICES	HI	F	No	Yes
1200547573100	CASIAS CONSTRUCTION, LLC	Frank D. Casias	SAN ANTONIO	frank@casiasconstructionllc.com	210-308-1067	General Contractor Specializing in Commercial Construction	HI	M	Yes	Yes
1742919890000	CEDA-TEX SVCS INC	Fred Odanga	CEDAR PARK	contact@cedatex.com	512-339-0155	General construction. New construction, Site, drainage, Interior drywall, plumbing, electrical Painting ,concrete work etc	BL	M	Yes	Yes
1261341513700	CEDAR BEETLE, LLC dba BADER CONSTRUCTION	KATY BADER	HONDO	trey@cedarbeetle.com	830-426-6453	Right of way services including clerling, environmental work, gates, roads and culverts. All types of land clearing including dozing, mulching, tub grinding, hand cutting, etc. Excavation services including lake and pond construction	WO	F	No	Yes
1851648613300	CHAPA'S CUSTOM SERVICES LLC	Erick Chapa	ALVIN	chapascustomservices@gmail.com	281-716-7968	site preparation, demolition, grading, grubbing, land clearing, excavating, welding, fabrication	HI	M	No	Yes
1814995251900	CLM CONSTRUCTION SERVICES, INC.	PresJennifer Coyle	COLLEGE STATION	jennifercoyle@mac.com	979-589-4010	Company performs general construction, civil/site work and underground utility construction.	WO	F	Yes	Yes
1464324140000	COASTAL BEND DEMOLITION INC.	VERNON CARR	CORPUS CHRISTI	Vernon@coastalbenddemolition.com	361-851-0464	Structural Demolition, Select Interior/Exterior Demolition, Civil/Site Demolition, Asbestos Abatement/Environmental Services, Site Prep, Clearing, Dirt Work, Commercial, Industrial and Governmental Emergency Response.	DV	M	Yes	Yes
1852359466300	COLLABORATE CONSTRUCTION COMPANY, LLC	Deborah Campbell	MISSOURI CITY	ccofhoustan@gmail.com	713-539-3522	Commercial construction, streets, buildings, bridges, concrete, marine construction, commercial diving.	HI	F	No	Yes
1752784423100	CON-E-MACK INC	MIKE MCDONALD	BONHAM	cmcdonald1944@yahoo.com	512-663-7577	Same as before	WO	F	No	Yes
1861328327600	CONFORMANCE LLC	MIRZA FARJAD BAIG	RICHARDSON	Farjadbaig@gmail.com	214-430-8492	Engineering Consultant and Contractor	AS	F	No	Yes
1200074905600	CONSTRUCTION ZONE OF TEXAS, LLC.	Tamra K Crosson	AUBREY	sandyb@cziglobal.com	940-365-1366	COMMERCIAL GENERAL CONTRACTOR - REMODEL/NEW CONSTRUCTION	WO	F	No	Yes
1272293470500	COPPERA, LLC	Rhonda Dowdy	TAYLOR	office@copperaco.com	512-365-1838	New Plumbing Construction & Remodel Plumbing Construction	WO	F	No	Yes
1751991843100	COX CONCRETE CONTRACTORS, INC.	Brenda Jones	NACOGDOCHES	bjones@coxcontractors.com	936-564-6500	Concrete Construction, General Construction, Construction Management, Design-Build, Architecture, Interior Design.	WO	F	Yes	Yes
1300402089000	CRAIGS DIRT SERVICE, LLC	Brittany Brown	LINDALE	brittany@craigsdirtservice.com	903-882-5096	Trucking, hauling, construction, dirt excavation, demolition	WO	F	Yes	Yes
1872581353100	CSA CONTRACTING, LLC	ROSA ALBIZTEGUI	EL PASO	ralbiztegui@grupocsa.com.mx	555-437-1709	Boring, Drilling, Including Concrete Coring,Construction, Street Lighting,Excavation.Striping: Streets, Lane Divisions, Maintenance, Sidewalk and Driveway, Including Removal,Underground Projects,Paving and Resurfacing, Alley, Highway and Road, Streets	HI	M	No	Yes

1462706182400	CT WALKER, LLC	CASSANDRA WALKER	AUSTIN	ct.walker@austin.rr.com	512-300-3080	General contractor, site work, concrete, utilities, fencing, landscaping, demolition, drywall, roofing, painting, construction management, material and equipment suppliers	BL	F	Yes	Yes
1800547507600	CVI DEVELOPMENT, LLC.	Karl Daniels	AUSTIN	karldaniels.mac@me.com	512-944-0280	Building Construction, including General Contractors and Operative Builders	BL	M	No	Yes
1800920788900	Calvo Construction, Inc.	Juan CALVO	Grapevine	jcalvo@calvoconstruction.com	817-394-3912	Underground Utilities Construction	HI	M	No	Yes
1300889873900	Coastal Consulting, Inc.	Robbie Garcia	Corpus Christi	rjcalvo@coastalconcretetx.com	361-739-1310	Concrete Services	HI	M	No	Yes
1742471700100	Con-Cor Inc.	Cy Canales-Jary	San Antonio	cyjary@con-corinc.com	210-375-8484	Building construction, general contractor, remodeling contractor	HI	M	No	Yes
1201621237000	Crain Group, LLC	President Phillip B Crain	PEARLAND	brad@craingroup.com	713-436-8727	Commercial General Contracting, construction and program management, and consulting. Green builder and certified installer of AAC (Autoclaved Aerated Concrete).	HI	M	No	Yes
1200265986500	Creed Construction, Inc.	Chester Reed	Mansfield	ruby@creedci.com	682-518-8835	Capable of engineering and building from ground up. Total mason builder, brick, block, stone, stucco, concrete restoration, cleaning, caulking, dampproofing and repair.	BL	M	No	Yes
1742523918700	D & S S CONSTRUCTION, INC.	Pres./JANNA SCHURY	CORPUS CHRISTI	janna@dssconstruction.com	361-992-3566	GENERAL CONTRACTOR.	WO	F	No	Yes
1205073365300	D&S Contracting, Inc.	DeAnne Smith	College Station	dandscontractinginc@verizon.net	979-690-9232		WO	F	No	Yes
1202159798900	D2 Excavating, Inc	Skip Sandell	Leander	nancy@d2excavating.com	512-338-0000	Excavating, Site Prep, Earth Work	WO	F	No	Yes
1814894430100	D4 LAND SERVICES LLC	Clinton Dempsey	KURTEN	d4landservices@gmail.com	979-676-1985	Land Clearing, Excavation, Forestry Mulching, ROW,	DV	M	Yes	Yes
1562589888500	DECENT CONSTRUCTION COMPANY, INC	SYED A HASHMI	PLANO	construction.decent@gmail.com	214-846-5113	General Contracting, Project Management, Site Work, Concrete, Masonry, MEP, Damp Proofing, Caulking, Sealing, Fire Safing and Selective Demolotion	AS	M	No	Yes
1824288646500	DMA CONTRACTORS INC.	Donna Allphin	PLANTERSVILLE	dallphin@sbcglobal.net	936-894-3533	Guardrail installation and repair, underground construction, directional boring, water well drilling, road and driveway building, backhoe and dozer work, mowing, all farm related construction, and concrete work, catering events	WO	F	No	Yes
1261672970800	DNA Trucking, Inc.	Arthur Pena	RICHMOND	dnatrucking@yahoo.com	281-650-5518	Dump Truck Hauling Service; Supplier of Sand, Rock, Gravel and Other Earth Materials	HI	M	No	Yes
1883737586600	DRB RECON SERVICES, LLC	Dillon R Burran	KENNARD	drbrecon@outlook.com	936-204-1913	Land/Forest/Road maintenance mulching, mowing, boring, clearing - right away, easement, forest thinning, dirt work etc	DV	M	Yes	Yes
1300590854900	DRC CONSTRUCTION LLC	Owner/Dawn Cockerill	BEAUMONT	drc.construction@yahoo.com	409-223-1420	DRC Construction is a residential custom home builder with experience in apartments, condos, townhomes, storm restoration, and light commercial. We can fulfill all your needs at an affordable price and in a timely manner with no acception to quality.	WO	F	No	Yes
1464469415100	DYNAMIC BASE CONSTRUCTION, LLC	Lisa Thoma	BURLESON	l.thoma@tarkettports.co	817-303-3484	Sports field and supportive athletic structures, natural grass, synthetic and artificial surfaces	HI	M	Yes	Yes
1844336908900	Demotik Construction Services, Co.	FELIX ROIGUEZ	HOUSTON	felix@develotik.com	305-956-6009	Construction remodel, demo, build back, commercial retail, high rise office tower, ground up, and signage.	HI	M	No	Yes
1862420681100	DuPre Site Services, LLC	Karen Owens	Buda	dupresiteservices@gmail.com	512-529-8096	land management and land clearing	WO	F	No	Yes
1752675055300	EARTH ONE, INC.	CEO/MARISA A. BASSO	PLANO	earth.one@tx.rr.com	972-881-5226	ENVIRONMENTAL CONSULTING AND PROJECT MANAGEMENT SERVICES; ASBESTOS SURVEYS	WO	F	No	Yes
1901025179100	EARTHCO LANDSCAPE CONSTRUCTION, LLC	Earthco Landscape Construction llc	GEORGETOWN	earthcolc@aol.com	512-818-7015	landscape/irrigation/design/drainage/erosion control supply & install/dirt work/excavation/trenching/hauling /concrete supply/concrete installation/demolition/retaining walls/tree trimming/tree removal/clearing/ heavy equipment & operators/pipe supply	BL	M	Yes	Yes
1820571726900	EAS CONTRACTING, L.P.	LAWRENCE PINZEL	PRINCETON	info@easlp.com	972-590-5576	Electrical Utility Contractor	BL	M	Yes	Yes
1923074620800	EP GEM ENTERPRISES LLC	George Cepeda	El Paso	gcepeda@valor-gc.com	915-740-6917	SDVOSB GENERAL CONTRACTOR WITH 20 YEARS IN UNDERGROUND UTILITIES, PAVING, CONCRETE AND PIPELINE WORK.	HI	M	Yes	Yes
1833167711400	ESA SOLUTIONS LLC	Paul Nguyen	LEAGUE CITY	paul@esas-llc.com	832-592-1100	Providing sales, service, and installations of electrical, security, CCTV, and access control.	AS	M	No	Yes
1810698979300	ESCOS CONSTRUCTION SERVICES, LLC	Jaime Escobar	FORT WORTH	escoscs@yahoo.com	817-707-1128	We are a statewide licensed growing company in the DFW metroplex and surrounding areas. Escos Construction Services offers Construction project cleaning, material delivery, dirt and haul off services as well as excavation and demolition.	HI	M	No	Yes
1477449224400	EZ DEMOLITIONS & UNDERGROUND, LLC	John Aguirre	Houston	cr@ezdemolitions.com	281-496-0401	Demolition, Land Clearing, Underground and Foundation Work/ Asbestos Abatement Services	HI	M	No	Yes
1820969765700	Eischen's General Contracting, LLC	Ava Sharifian	Austin	ava@egcatx.com	512-445-0128	To provide general contracting services that focuses on remodeling residential properties and buildings. Also firm maintains trails and bridges. The firm mainly provides landscaping services.	WO	F	No	Yes
1371623274200	El Dorado Services, Inc	Frank Lopez	Houston	eldoconstruction@gmail.com	713-530-6204	General Construction and Repairs, Concrete Construction, Dirt Work, and Underground Utilities (Storm Line and Sanitary Sewer Lines) Erosion Control, Rip Rap, concrete sidewalks driveways streets,	HI	M	No	Yes
1844275691400	FIREFLY DEVELOPMENT LLC	Maria Schneider	CARROLLTON	bids@FireflyEarthworks.com	214-717-1181	demolition, site prep, earthwork, hauling, aggregates, dumpsters	WO	F	No	Yes
1821152199400	FORREST INDUSTRIAL GROUP LLC	Jeffery Forrest	TOMBALL	forrestindustrial.llc@gmail.com	832-620-2321	Forrest Construction specializes in residential and commercial remodeling and construction services including carpentry, mill-work, flooring, and also provides project management services including estimation.	BL	M	No	Yes
1742784213700	FOSTER CM GROUP, INC.	Paul Foster	SAN ANTONIO	satirahf@fostercmgrou.com	210-804-1004	Program / Construction Management	BL	M	Yes	Yes
1882298753500	FRAUSTO - CASTILLO CONSTRUCTION GROUP, L	Alfredo Frausto	SAN ANTONIO	info@fconstructiontx.com	210-737-4791	Construction management, commercial and institutional building, Poured Concrete Foundation and Structure Contractors, Framing contractors, Masonry Contractor	HI	M	No	Yes
1824334572700	FREEDOM CS, LLC	Clint Hobbs	TYLER	freedomconstruction97@gmail.com	903-360-1158	Excavating, paving, demolition, site work, land clearing, aggregate hauling.	WO	F	No	Yes

1272425295700	FRONTLINE SUPPORT SOLUTIONS, LLC	Jose Perez	SAN ANTONIO	todhiambo@frontline1.com	210-630-6750	Frontline Support Solutions, LLC is a general contractor specializing in commercial and industrial construction. Additionally, we provide facility support services to large commercial and industrial parks, and military installations.	HI	M	No	Yes
1743002047300	Five B's Construction & Utilities, Inc.	PresidentBrenda K Lackey	SPRING BRANCH	fivebsconstruction@gvtc.com	830-980-2714	Site work, utilities, land clearing, backhoe work, concrete, bobcat services.	WO	F	No	Yes
1743002355000	G & E ESCOBEDO CONSTRUCTION, INC.	Geronimo Escobedo	MISSION	gescobedo@aol.com	956-585-1429	Excavation, Bores, Bury Telephone Cable	HI	M	Yes	Yes
1853799013900	G-8 UTILITIES LLC	Claudia Ochoa	MISSION	claudiag8utilities@gmail.com	956-627-1327	As a utility company our primary job is to maintain systems to efficiently provide water and process sewage including but not limited to trenching, installing water lines, sanitary sewer, storm drainage, earth work and site clearing.	HI	F	No	Yes
1752205887800	G. L. MORRIS ENTERPRISES, INC.	Pres./Marla K. Murphy	CARROLLTON	marla@sun-belt.com	817-877-0866	Environmental Contractors, Excavation, Tank Removal, Drum Transportation, Soil Transportation & Disposal, Demolition, Hazardous Materials Handling, Treatment System Installation, Environmental and Geotechnical Drilling	WO	F	No	Yes
1270296441700	G2 CONTRACTORS, LLC	Heather McGlasson	Mason	heather@g2contractors.com	817-739-6560	General Contractor / Certified Construction Manager (CCM) who primarily works with land management and historical government agencies in all Regions within the State of Texas. Performs any type and size of project in Texas.	WO	F	Yes	Yes
1834050961300	G2 Construction Services, Inc.	Jyl Gibson	Georgetown	jyl@g2csinc.com	512-688-5725	Commercial general contractor specializing in General Contracting, Design Build, Construction Management, Planning & Development, Pre-Construction Consulting. TIPS JOC awarded contractor.	WO	F	Yes	Yes
1742138792300	GAINCO, INC.	Theresa Nix	PORTLAND	t.nix@gaincoinc.com	361-643-4378	Full service environmental remediation company providing environmental drilling, waste management, remediation and remediation systems, tank cleaning, demolition, UST removal and emergency response	WO	F	Yes	Yes
1810633810800	GARCO INDUSTRIES, INC.	Blanca Garza	MCALLEN	garcoutilities@yahoo.com	956-783-1695	Utilities and paving	HI	M	No	Yes
1464815031700	GLOBALIZE AMERICAN SAFETY, LLC	Margaret Johnson	RICHMOND	GlobalizeAmerican@gmail.com	713-301-4336	Demolition, Drywall & Insulation Installation, Door, Windows, & Cabinet Installation, Finishing Work, Flooring, & Framing/Hauling/Debris Removal via Pickup Truck & Janitorial Services	BL	F	No	Yes
1853479887300	GRANCHELLI CIVIL CONSTRUCTION, LLC	James Granchelli	MCALLEN	jim@granchelliconstruction.com	956-928-1122	Heavy civil, earthwork, utilities, concrete structures, roads, streets, bridges	WO	F	Yes	Yes
1264438537400	GREENWORLD CONSTRUCTION	Michael Torres	AUSTIN	admin@gwmaterials.com	512-797-9876	Framing, Sheathing, Decking, Roofing, Exterior Siding, Insulation, Concrete Foundations, Drywall, Patios, Decks, Fences, multifamily, student housing, single family, industrial	HI	M	No	Yes
1454293083000	GUETTLER SERVICES LLC	Dennis Guettler	DAYTON	Guettlerservices@att.net	936-258-7170	excavation and underground storage tank contractor.	WO	F	No	Yes
1200797158800	Gap Engineering, Inc.	Mike Homma	Katy	mhomma@gap-eng.com	281-578-0500	Gap Engineering is a full service general contractor specializing in quickly mobilizing and executing projects for state and local government	AS	M	No	Yes
1464841006700	Greenstone Electrical Services, LLC	Margo Williams	Spring Branch	margo@greenstoneelectric.com	210-954-6635	Electric distribution overhead and underground powerline construction, maintenance & emergency services. Experienced Journeyman Power Lineman and equipment. Utility Services; risers, transformers, wire, meters, conduit, infrastructure, excavation.	WO	F	Yes	Yes
1260439585000	H3 CONSTRUCTION, LLC	Roxanne Hunt	ROANOKE	linda@h3-construction.com	940-295-4488	Concrete Work, Concrete Cutting/Coring, Wall Sawing, Electric Sawing, Flat Sawing, Selective Soft Demolition, Concrete Repair/Paving/Removal, Excavation, Hydro Excavation, Dirt Work, Ground Penetrating Radar, Roll Off Dumpster Rentals,	HI	M	No	Yes
1271774963900	HAMPSHIRE CONSTRUCTION &	BOBBY HAMPSHIRE	BUNA	colean@hampshireconst.com	409-751-6826	General Contractor	WO	F	No	Yes
1845052116800	HARDEN ENTERPRISE SERVICES LLC	Clyde E Harden Jr	POINT BLANK	admin@heservices-llc.com	281-410-8837	Commercial and Residential Construction Management	BL	M	Yes	Yes
1464025568400	HAVOC SERVICES	JACOB URIAS	MIDLAND	urias_jacob80@yahoo.com	432-556-3221	General Contractor	HI	M	Yes	Yes
1203059002500	HEARTS FOR HOMES	Owner - Maureen Moulton	SAN ANTONIO	moultonm001@hotmail.com	210-421-9144	HEARTS OF HOME	WO	F	No	Yes
1383884246900	HEAVY ROADWAY CONSTRUCTION SERVICES, LLC	Mario Alcantara Cano	CEDAR PARK	mario@heavyroadway.com	512-567-8710	Firm provides highway construction services. Excavation and demolition services, and site clean-up.	HI	M	No	Yes
1264112040200	HYDRO SPY, LLC	Richard Young	HOUSTON	bids@hydrospy.com	281-501-3506	Hydro Excavation, Vacuum Excavation, Line Locating, Excavation, Line Cleaning, Foundation Digging	BL	M	Yes	Yes
1900386225700	Horns Crew Trucking LLC	Alvin Horn	Longview	hornscrowhornscrew@yahoo.com	903-387-2059	Hello! We provide Freight transport,cleans up Construction, Waste disposal hauling,Mowing, Landscaping, Disaster remedies,Towing,Hot Shot Service,and Heavy civil engineering work.	BL	M	Yes	Yes
1205902011000	IMANI QUALITY CONCEPTS, LLC	Hardy Jones III	BEAUMONT	imaniqualityconcepts@gmail.com	409-842-4700	New construction, remodeling, janitorial services and debris removal provided for residential and commercial.	BL	M	Yes	Yes
1883991989300	IMPERIAL TOTAL SOLUTIONS LLC	Ben Adeleke	Arlington	info@imperialtotalsolutions.com	469-412-5788	The company specializes on small to medium size projects, Project planning, application design, consultancy and general contracts.	BL	M	Yes	Yes
1455536935500	Isro Engineering Services, PLLC	Juan Rodriguez	Converse	isro.group@gmail.com	210-793-8136	Engineering services, Utilities management consulting services, All Other Professional, Scientific, and Technical Services.	HI	M	No	Yes
1752862904500	J NICHOLS CONSTRUCTION, INC.	Melissa Nichols	WYLIE	melissa@jnicholsinc.com	972-412-8000	General Construction , New and Re-Model. Site Services, Mowing, Landscape and Maintenance.	WO	F	No	Yes
1383808023500	J. RIVAS CONSTRUCTION LLC	Jorge A. Rivas	Houston	j.rivasconst@yahoo.com	346-401-7105	We perform many waterline underground utilities, concrete paving and repair, sanitary and storm sewer new and existing, excavation and earth work, drainage and erosion control	HI	M	No	Yes
1741618550600	J.R. (Joe) Ramon & Sons, Inc.	Tim Ramon	San Antonio	beatriz@ramondemolition.com	210-225-1583	All things demolition. Complete, Interior, Selective Demolition services along with site preparation	HI	M	Yes	Yes

1742527948000	JACQUEZ CONSTRUCTION AND TRUCKING LLC	Billy Jacquez	TOMBALL	billy.jac@outlook.com	832-526-8763	Construction Services, Concrete Structures, Dirt Work, Sand Blasting and Painting, Underground Utilities, Bulkheads, Boat Ramps, Pier Building, Tank Leak Repairs, Tank Building General Contracting	HI	M	Yes	Yes
1201931167400	JAMCO Ventures, LLC	Joe Muniz	San Antonio	joe.muniz@jamcoventures.com	210-270-7609	General Contractor, Construction, Sewer, Concrete, Utilities, HVAC, Electrical, Communications, Computer Cabling, Fire Alarm & Protection, Cooling Tow	HI	M	No	Yes
1830389027300	JENNRAND DIVERSIFIED, L.L.C.	Randy Randolph	TATUM	jennrand@outlook.com	903-557-1070	General Contractor-Residential and Commerical: Commodity Broker	BL	M	No	Yes
1113657737300	JERRY DALE, INC.	Jerry Dale	DALLAS	office@bluesteelgc.com	972-890-3681	Blue Steel General Contracting provides complete construction and remodel for Commercial & Residential.	BL	M	No	Yes
1821331961100	JERSON'S CONCRETE LLC	Jerson's Concrete LLC	HOUSTON	jersonsconcrete@yahoo.com	832-873-9997	Ready Mix Delivery Services Build foundations, sidewalks, driveways, parking lots , etc	HI	F	Yes	Yes
1760387880600	JIMERSON UNDERGROUND, INC.	Alicia Jimerson	STAFFORD	alicia@jimerson.net	281-261-0976	Underground Utility Construction	WO	F	No	Yes
1833400394600	JM Transport LLC	Jeffrey Martinez	Buda	jmtransport2019@gmail.com	512-995-6288	JMT Provides Transportation Services, Site Preparation Contractors, Demolition Services, Construction, Sand and Gravel Mining, Specialized Freight and General Freight Trucking to State & Federal Government, Private Companies & General Customers.	HI	M	Yes	Yes
1201628628300	JMR DEMOLITION, LTD.	Martha Robles	EL PASO	jesse.robles@jmr-demolition.com	915-858-0376	Demolition of Commercial and Residential Properties; Interior and Exterior, For Private Owners and/or General Contractors.	HI	M	No	Yes
1204274008900	JON TUCKER CONSTRUCTION, LTD.	ALLISON TUCKER	BRYAN	office@jontuckerconstruction.com	979-589-3471	Demolition, earthwork, concrete foundations, structural concrete, curb & gutters, site concrete, concrete sawcutting	WO	F	No	Yes
1760416259800	KA-TEX CONSTRUCTORS INC	RENE GRIFFITH	HOUSTON	rene@katexconstructors.com	713-692-0707	GENERAL CONTRACTOR. COMMERCIAL CONSTRUCTION/OFFICE BUILDOUT, ETC.	WO	F	No	Yes
1471519062600	KEE Concrete and Construction, Inc.	Kelley Eubanks	FORT WORTH	ke@designconstructbykee.com	682-559-2952	Consulting ---- heavy civil; road and bridge; concrete admixtures, spray-applied fireproofing	BL	F	No	Yes
1202112296000	KIESCHNICK GENERAL CONTRACTORS, INC.	DANA KIESCHNICK	WELLBORN	dana@kieschnickgc.com	979-690-0710	COMMERCIAL GENERAL CONTRACTOR SPECIALIZING IN SITEWORK & UNDERGROUND UTILITIES	WO	F	No	Yes
1760419501000	KT MAINTENANCE COMPANY	JAMES BOWERS	PORT ARTHUR	kenny.tims@ktmaintenance.com	409-982-9952	Provision and onsite supervision of well-trained 3rdparty safety attendants, certified flaggers and monitor techs	BL	M	No	Yes
1742479057800	Kegley, Inc.	Anita Kegley	San Antonio	anitakegley44@gmail.com	210-857-4994	Construction Inspections, Client Representation on apartments, manufacturing buildings and commercial spaces. We represent our clients who need general contracting, project management, and design build construction.	WO	F	No	Yes
1208072757600	Kocurek Land Improvement, Inc	Amanda Kocurek	Banquete	Amanda@KLeearthmovers.com	361-500-2663	Heavy construction.	WO	F	Yes	Yes
1742939910200	L & G CONCRETE CONSTRUCTION, INC.	President/Erasmio Lopez	MERCEDES	bids@lgconcrete.com	956-565-6334	Concrete construction specializing in Title walls, foundations and concrete paving.	HI	M	No	Yes
1271753727300	L&M Aerial & Underground, LLC	Melanie Cornish	Midlothian	melanie@landm-utility.com	214-912-1282	We are currently involved in trenching, boring, aerial, splicing, pole placement, line locating and management services in the Utility Industry.	WO	F	Yes	Yes
1820864435300	L.T.N INC PROFESSIONAL SERVICES	Joseph F. Birl	HUMBLE	joseph@ltnincprosvcs.net	281-755-5797	We are a residential and commercial renovating company.	BL	M	Yes	Yes
1852789510800	LAFORTE CONSTRUCTION, LLC.	Orlando Carrillo Maffei	DALLAS	orlando@laforteconstruction.com	305-316-2277	Concrete Roads, Parking Lots, Driveways, Sidewalks, Curbs, Gutters, Residential Leadwalks, Ramps, Retaining Walls, Floors, Columns, Walls, Stairways, Patios, Slabs, Pavers, Roofs, Kitchens, Bathrooms	HI	M	No	Yes
1742945219000	LASALLE AFFORDABLE BUILDERS LLC	Maribel Morales	Castroville	maribel@lasalleab.com	210-415-7912	Addition, alteration and renovation general contractors, commercial and institutional building, Concrete finishing, Concrete product (e.g., structural precast, structural prestressed) installation	HI	F	No	Yes
1270740505100	LDC PAVING INCORPORATED	Chawauai Davis	HOUSTON	estimates@LDCpaving.com	832-640-7296	Provides complete pavement maintenance, marking, concrete wheel stop installation, and signage services for commercial parking lots and roadways.	BL	M	Yes	Yes
1813219819500	LOCKE CONSTRUCTION SERVICES, LLC.	Angie Harrison	N RICH HILLS	angie@lockectsx.com	214-549-1717	General Commercial Construction Services and Equipment Acquisition.	WO	F	No	Yes
1261821531800	LOPEZ UTILITIES CONTRACTOR, LLC	Ricardo M Lopez	SOUTH HOUSTON	Rm.lopez@sbcglobal.net	713-987-9719	We focus on the reconstruction and new construction of underground utilities.	HI	M	No	Yes
1820775416100	LOYOLA CONSTRUCTION, LLC	Jessica Loyola	NEW BRAUNFELS	loyolaconstructionllc@gmail.com	830-743-5336	We offer all concrete related jobs weather it be New foundations, sidewalks, curbs , parking lots. We also do repairs to buildings like roof repairs, floors, walls etc.	HI	F	No	Yes
1364554184100	LSJ TRUCKING, INC.	Lesley J Juman	BEAUMONT	lsjtrucking@att.net	917-709-7160	Trucking of goods for groundwork projects. Example of materials is sand, gravel asphalt, aggregate and excavation. We do haul off and haul in of materials.	AS	M	No	Yes
1742503615300	Lozano Construction Co., Inc.	Pete Lozano	San Antonio	rosanloza@aol.com	210-626-2880	BUILDING AND CONSTRUCTION	HI	F	No	Yes
1462436689500	M. Serrano Construction Llc	OwnerMANUEL SERRANO	MISSION	mserranoconstr85@aol.com	956-424-5215	BACKHOE SERVICE - EXCAVATION -Backfill.	HI	M	No	Yes
1272034726400	M2 Federal Inc.	Michael Scheiern	San Marcos	info@m2federal.com	512-878-1050	Specialize in Elevator Modernization, Maintenance and Repair Services, Commodity Sales, Site Work, Utilities, Concrete, Steel Structures, Exterior Coatings, Painting, Waterproofing, Floor coatings, Metal Buildings, Roofing, Parking Lots, Earthwork	DV	M	No	Yes
1742490361900	MALTBY BUILDERS, INC.	SANDRA MALTBY	KINGSVILLE	maltbybuilders@sbcglobal.net	361-592-8426	COMMERCIAL & RESIDENTIAL-NEW & REMODELING	WO	F	No	Yes
1823660718200	MAMMOTH FOUNDATION REPAIR, LLC	Edgar Aguilera	CORPUS CHRISTI	mammothfoundationrepair@gmail.com	361-876-2722	General Contractor- residential & commercial construction-framing, concrete, roofing, electrical, plumbing, painting, renovations, new construction, design build	HI	M	Yes	Yes
1841978311500	MARQUEE PROPERTY SERVICES LLC	Brittany Brown	CYPRESS	accounting@marqueepropertyservicesllc.com	832-372-9304	Construction Management/Maintenance, General Construction, Powerwashing, Striping, Concrete	BL	M	No	Yes
1825053318100	MARRS PATRIOT CONSTRUCTION, LLC	Lance B Marrs	WICHITA FALLS	marrspatriotconstruction@gmail.com	940-500-5718	Residential and commercial remodeling	DV	M	Yes	Yes

1752570370200	MARTIN GONZALES, INCORPORATED	VP/ Adrian Gonzales	ANDREWS	adrian@martinsinc.com	432-523-6522	OIL FIELD SERVICES, CONSTRUCTION, Environmental Remediation, Concrete, Cement, dozer, excavator, mower, shredder, backhoe, roustabout, haul truck, pipe, vacuum, backhoe, road construction, road maintenance	HI	M	No	Yes
1823354733200	MEL Properties	Ermilo Elizondo	Houston	melproperties@sbcglobal.net	832-971-5100	Commercial Construction, Demolition, Railroad Construction, Civil Work, Land Clearing, Dirt Work, Excavation, Contracting, Preservation of Residential and Commercial Properties, Remodeling Homes, Marine Sheet Piling	HI	M	No	Yes
1861934354600	MID-TEX CONTRACTING LLC	BRENNA SIMS	WHITNEY	brenna@mid-texcon.com	254-495-5665	General constructions services including MEP. Addition, alteration and renovation, general contractors, industrial building (except warehouses) , Construction management, commercial and institutional building, All Other Specialty Trade Contractors	WO	F	No	Yes
1263344612000	MILCON CONSTRUCTION, LLC	Armando Aranda	SAN ANTONIO	rocky@milconco.com	726-202-3950	All PLUMBING SERVICES,REMODELS,TI'S, NEW CONSTRUCTION,INSTALLATIONS,ADA,SMOKE TESTING water heaters, water,sewer,gas,air lines,sand ,grease traps,slab leaks,cancellations,pipe diagnosis,air dryers,septic pumps,lift stations,custom bathrooms,re-routing	HI	M	No	Yes
1742741319400	MISSION PLUMBING COMPANY	Larry Mendoza Jr	EL PASO	missionplumbing@elp.rr.com	915-630-6791	General Contractors specializing in remodeling and new construction. Scope of work includes any and all phases of construction including design/build, project management, quality control, and specific trade construction (arch, mech, elect work).	HI	M	Yes	Yes
1742890583400	MLP Ventures Inc.	Liborio Perez	Von Ormy	mlp@att.net	210-623-8172	Land management, clearing, mulching, excavation, grading, mowing and shredding, hay baling, dirt work, foundation drainage, and metal buildings.	WO	F	Yes	Yes
1832684578300	MUDDY BOOT CATTLE COMPANY LLC	Victoria Fletcher	HUBBARD	victoria.fletcher@muddybootcontracting.com	254-229-7524	Engineering Consulting; Program/Project/ Construction Mgmt; Rehab & Improvement of Infrastructures/Engineering Services, General Management Consulting Services & Project Management/Repair of Metal and Concrete Structures/Coating/ FRP Design Calculations	HI	M	No	Yes
1470957150000	Madero Engineers & Architects, LLC	Frank Madero	Houston	frank@madero.net	281-610-0367	We install and repair water, sewer, storm main, and manholes. Demolition, and concrete installation	BL	M	No	Yes
1834023697700	Meysong, LLC	Randall Thompson	Terrell	randall@meysongllc.com	940-442-3919	General Contracting	WO	F	No	Yes
1204596978400	N.A.E. ENTERPRISES, INC.	Pres Chantal Dauenhauer	FT WORTH	ce.dauen@naecontracting.com	817-220-2200	Design/Build - collaborative architectural services - construction administration - General Contracting	BL	M	Yes	Yes
1383806059100	NECHEMYA CONSTRUCTION	Principal - Daleth Johnson	NORTH RICHLAND HIL	daleth@nechemyasolutions.com	214-274-0750	We are a general construction and technology solutions company. We offer residential and commercial building construction services along with technolo	BL	M	No	Yes
1474493752600	NEXLEGACY LLC	Kendrick Whittington	HUTTO	kendrick@nexlegacyconstruction.com	512-426-9688	environmental consulting, soil and groundwater remediation, environmental site assessments and impact studies, waste management, emergency spill response and abatement, mobile onsite water treatment with activated carbon, skimming of oil/water separators	DV	M	No	Yes
1473302832900	NFA ENVIRONMENTAL, LLC	chris haugstad	BULVERDE	chris.haugstad@nfaenvironmental.com	702-353-5729	Voice & data cabling, fiber optic cabling, Job Order Contracting	WO	F	Yes	Yes
1752692487700	NOUVEAU TECHNOLOGY SERVICES, LP.	Brian Beiling	CARROLLTON	bbeiling@ntslp.com	972-484-5077	General contractor, commercial building remodels, exterior site work, interior remodel, HVAC, Electrical, Sheetrock, framing, texture and paint, flooring, ceiling, roofing	HI	M	No	Yes
1452910724600	NOVIUM GROUP LLC	Managing Mbr/Tyler Walbridge	AUSTIN	tylerw@noviumgroup.net	512-767-2478	Hauling By Dump Truck/Supplier of Earth Materials	HI	F	No	Yes
1760456826500	North Houston Trucking	Maria Richbourg	Pinehurst	bettyjo@northhoustrucking.com	281-252-6500	Earth moving and excavation dump trucking and construction equipment rentals	HI	M	Yes	Yes
1352382849200	ONNEA EQUIPMENT, LLC	Roque Campos	SPLENDORA	rcampos@heavyequipmenttx.com	281-689-5150	Material hauling sand gravel top soil	HI	M	Yes	Yes
1465498237100	Occupational Safety Solutions	Bradford Holman	Elgin	ossolutions@outlook.com	512-686-1381	OSS provides safety management consulting in the areas (1) OSHA 10/30 hour Training and safety awareness i.e. Flagger, CPR, Development of written safety programs, conducting site safety audits, air monitoring and sale of safety supplies.	BL	M	No	Yes
1270963759400	OnSite Contracting, LLC	Benny Ximenez	San Antonio	lois@onsite-contracting.com	210-472-2345	Building Construction, Site Construction, Rehab, Concrete, Steel, Renovations	HI	M	No	Yes
1273358266700	PANDO CONSTRUCTION, LLC	Robert Pando	MIDLAND	pando432@gmail.com	432-425-5566	Oilfield Construction, Commercial Construction, Excavation, Pads, Roads, Demolition, Custom Material Crushing TXDOT approved, Concrete & Asphalt Paving, Concrete Tear Out, Material Hauling, Site work, Earthwork, All Heavy Machinery Construction	HI	F	Yes	Yes
1465065270500	PARK CONSTRUCTION & BUILDING MAINTENANCE	Nathan Park	ROYSE CITY	megan@parkcbm.com	972-636-2260	We are a general contractor and all around commercial building maintenance contractor. We do but are not limited to concrete, masonry, erosion control, remodels, plumbing, electrical, cleaning, grading, debris removal and clean up, demolition.	AI	M	No	Yes
1881800854400	PAVEWAY CONSTRUCTION LLC	Butch Thompson	DALLAS	Sales@PaveDFW.com	214-680-7000	Asphalt Paving, Concrete Paving, Seal Coating, Striping, Repairs and new construction. Parking lots, sidewalks roads, dumpster pads and more	AS	M	No	Yes
1833063256500	PBS CONSTRUCTION, LLC.	Paula Salvaggio	FARMERSVILLE	info@pbs-construction.com	972-775-0897	PBS provides a wide array of construction needs. Turn-key new construction, renovations, specialty construction, demolition, planning, flatwork, landscape and hardscape, environmental.	WO	F	Yes	Yes
1710966286000	PERPETUAL DEVELOPMENT, LLC	Ahmad R. Drumgo	HOUSTON	admin@perpetualhomes.com	713-742-3336	General Contracting Firm ,Specializing in Demolition project,Buildout Building maintenance, management and consulting.	BL	M	Yes	Yes
1760660283100	PILGRIM CONTRACTORS, INC.	Pres./Elise Carranza	PINEHURST	elise.carranza@pilgrimcontractorsinc.com	281-356-7647	Commercial and Residential construction.	HI	F	No	Yes
1201111385400	PILLAR AND STRONG INC.	OwnerLee Olawale	HOUSTON	lee@pillarandstrong.com	713-780-3100	Construction.	BL	M	No	Yes

1752404077500	PINTO CONSTRUCTION CO., INC.	Theresa Ann Ainsworth	NACOGDOCHES	chinton0810@yahoo.com	936-569-6155	HEAVY HWY CONSTRUCTION	WO	F	Yes	Yes
1742513704300	PITTS CONSTRUCTION, INC.	PresMary Schneider Pitts	AUSTIN	pittsconstructioninc@gmail.com	512-327-4040	Underground Utilities - wet and dry.	WO	F	No	Yes
1113724341300	PRESTIGE I REAL ESTATE FIRM, LLC	Kimberly Williams	CYPRESS	kwilliams@remax-allstars.com	281-213-8989	Real Estate Service (Commercial & Residential) and Rent Market Analysis	BL	F	No	Yes
1752662137400	PROTECT ENVIRONMENTAL SERVICES, INC.	Alicia Cameron	HALTOM CITY	acameron@protectusa.net	817-589-9005	Emergency spill response, remediation, confined space operations, hazardous and non hazardous disposal, facility and trailer decon, tank removals, roll off boxes, frac tanks and dewatering boxes	WO	F	Yes	Yes
1455204194000	PROTECT TRANSPORTATION, LLC	A. Kirsten Cameron	HALTOM CITY	akcameron@protectusa.net	817-589-9005	Transportation of hazardous and non hazardous material	WO	F	Yes	Yes
1473553089200	Packard Building Services, LLC	Keenan Packard	Grand Prairie	kpackard@packardservice.com	682-401-7705	General Contracting; Construction Management	BL	M	No	Yes
1884114591700	Phoenix Land Services		ARANSAS PASS	info@southtexaslandservices.com	361-444-8887		HI	M	No	Yes
1473869632800	Precision Power Solutions	Cesar Ramirez	Houston	cesar.ramirez@precisionpower.solutions	832-860-8067	Electrical Contractors Including Data Communication, Cabling, Electrical Signage Installation, & Energy Management Systems Services	HI	M	No	Yes
1203109350800	Prestique, Inc.	Lisa Cunningham	Dayton	lisa@rangerroof.com	281-328-3678	General Construction for commercial, industrial and residential customers	WO	F	No	Yes
1461542641900	Q Recycling & Construction Services, Inc	Murtaza Badri	Cyprss	info@qrecycling.com	832-263-0152	Q Recycling & Construction Services is a demolition and earth work contractor.	AS	M	Yes	Yes
1020720408100	QUALITY INNOVATIONS, INC.	President / Michele L. Morgan	BOERNE	Michele@Qi2LLC.com	281-705-8709	GENERAL CONTRACTOR AND MATERIAL SUPPLIER FOR CONSTRUCTION PROJECTS	WO	F	No	Yes
1852602152400	QUALITY WORK DONE RIGHT ALL IN ONE, LLC	GWENDOLYN JACKSON	DESOTO	gaj8766@att.net	214-429-5310	I am setting up to broker loads, I am a realtor, renting, SLP, flipping homes, fencing, and roofing	BL	F	No	Yes
1742905554800	QUEST CONTRACTING, INC.	PRESIDENT/JOSE GALLEGOS	EL PASO	j.gallegos@questcontracting.net	915-857-2733	DIRT & PAVING CONTRACTOR	HI	M	No	Yes
1760415205200	Quantum Environmental Consultants, Inc.	Bennie Benford	Houston	b.benford@qeci.com	713-961-9975	Environmental Consulting, Site Assessment And Remediation Design	BL	M	No	Yes
1474017716800	R & D DIRT WORKS AND CONSTRUCTION	Patrick Ferrand	PASADENA	rddirtworkspatrick@gmail.com	281-891-0496	Land Development,Site Development,Lime Stabilization,Concrete Flat Work, Site Grading, Demolition,Commercial Building Pads, Residential Building Pads,Parking Lots,Lime Slurry Distribution,Fly-Ash Distribution,Storm Water Drainage	HI	M	No	Yes
1815028277200	R3 RESOURCES, LLC	Rachelle Webster	CYPRESS	shelly.r3texas@gmail.com	832-439-1232	Construction and Remediation Consulting Services with an Environmental Focus	WO	F	Yes	Yes
1262775390301	RACHEL BYRANT CO	Rachel Rawlings	GALVESTON	rachelbryantco@gmail.com	855-504-5500	Our Commercial division offers innovative solutions for public & private sectors-Interior build-out & Alterations as general contractor and/or Subcontractor.	WO	F	No	Yes
1262618473800	RAM CONCRETE & ASPHALT, LLC	Jose Meza	Lewisville	newservice@ram-ca.com	469-458-9700	Concrete & asphalt flat work, ada ramps, driveways, retaining walls, sidewalks, new paving and repairs	HI	M	Yes	Yes
1800345488300	REMOLINO, INC.	OwnerJoel L Garcia	Mustang Ridge	Joel@bcstustin.com	512-454-9090	Commercial Turn-key Concrete Structures Including Multi-Story, Schools, Banks, Retail Stores , Medical Facilities, Site Improvements	HI	M	No	Yes
1814439770200	RIGHT CHOICE DEVELOPMENT AND CONSTRUCTIO	Danielle Wright	KATY	danielle@rightchoicedev.com	832-567-9648	Right Choice Development & Construction is a female-owned, Houston based commercial general contractor that specializes in corporate interior and exterior remodels and build-outs, retail spaces, shopping centers, industrial spaces and office buildings.	WO	F	Yes	Yes
1432014240000	RISE RESIDENTIAL CONSTRUCTION, LP	Melissa Fisher	DALLAS	Mfisher@rise-residential.com	972-701-5558	Our principal line of business includes multifamily residential rehabilitation construction projects. We have been in business since 2003, and our principals have over 35 years of experience and 9,000 units on the ground.	WO	F	No	Yes
1201861256900	RIVER CITY EXCAVATION, INC.	Cecily Byrom	SAN ANTONIO	cecily@rivercityexcavation.com	210-649-3937	Excavation and hauling	WO	F	Yes	Yes
1742731913600	RML HAULING & MILLING, INC.	MINERVA G. JUAREZ	BROWNSVILLE	rmlinc3293@gmail.com	956-546-3750	Site Preparation Contractors, Storm sewer construction, Boring, drilling, and milling machine combinations, Hauling	WO	F	No	Yes
1742819524600	RODRIGUEZ BARR INC.	Maricela Rodriguez Barr	AUSTIN	office@thebarrcompany.com	512-474-4222	CONSTRUCTION/PROGRAM MANAGEMENT; ARCHITECT 054075	HI	F	No	Yes
1464488908200	RORO'S TRAILER RENTALS & SALES LLC	Rogelio Rodriguez	BROWNSVILLE	rorotrailerrental@hotmail.com	956-579-7072	Utility Trailer rentals and sales. Enclosed, horse, bumper pull, gooseneck. Skid steer rentals, skid steer auger rentals, mini excavator rental.	HI	M	Yes	Yes
1465218100000	RUCOBA & MAYA CONSTRUCTION, LLC	Rodolfo Rucoba	KYLE	florencio@rmconstructiongroup.com	832-867-6673	Special Trade Construction	HI	M	No	Yes
1751324749800	RYKIN PUMP CO INC	Amy Dennis	ODESSA	sales@rykinpump.com	432-580-0101	Electrical Contractors Irrigation Service Station Equipment Installation of Fueling Systems	WO	F	Yes	Yes
1743015411600	Ramroc Construction Company, Ltd., LLP	Joe Ramirez III	San Antonio	info@ramroccconstruction.com	210-226-4828	Industrial building (except warehouses) construction, general contractors, Commercial building construction general contractors, Masonry Contractors and Other Services to Buildings and Dwellings.	HI	M	No	Yes
1471549646000	Real Estate Chasers, LLC	travis louie	San Antonio	Travis@RECONSTRUCTION.BIZ	210-563-9169		AS	M	No	Yes
1760567369200	Redwine Construction Co. (Redwine Enterp	REDWINE, PATRICIA KPAT	NEDERLAND	TREDWINDE@GT.RR.COM	409-722-8373	Dirt pit, transportation, earth work, and land development	WO	F	No	Yes
1831424454400	S-CON CONSTRUCTION, LLC	Ashley Villalobos	CORPUS CHRISTI	ashley@s-conconstruction.com	361-299-5161	General Construction, site work, trenching, building renovations.	HI	M	No	Yes
1760322250000	S.S. CONSTRUCTORS, INC.	Amy Schovajsa	HUMBLE	Tsc909@aol.com	281-441-8096	Underground Utilities to include Excavation, Boring Saw Cutting, and Removal and Replacement of Concrete/Asphalt	WO	F	No	Yes
1274523579100	SABINE INDUSTRIAL SOLUTIONS, LLC	Kari Potter	CENTER POINT	kari@potter-construction.com	830-285-2684	Our services include but are not limited to: Heavy Equipment & Excavation Work, Civil Work, Oil Field Site Remediation Work, Environmental Clean Up & Waste Disposal, Demolition and Debris Removal	WO	F	Yes	Yes
1471399648700	SAW DIAMOND BLADES OF STEEL, LLC	Oshunti Foley	DESOTO	info@sdbofsteel.com	469-548-4184	Saw Diamond Blades of Steel, is a Concrete Cutting Construction Company based in the Dallas Fort Worth area. SDBS specializes in providing expert concrete cutting, core drilling, wall sawing and slab sawing, demolitions, masonry, asphalt and scanning.	BL	M	No	Yes

1760192206900	SEPARATION SYSTEMS CONSULTANTS, INC.	Lisa Landers	HOUSTON	ssci@sscienvironmental.com	281-486-1943	Engineering, Construction, & Enviro Services: Fuel System Design-Install-Removal-Closure & Remed; Site Assessments; SPCC Plans; Asbestos; Lead Paint; Haz Waste; WO NEPA; Compliance & Permit; Project Oversight; Wetlands; Detention/Stormwater	WO	F	Yes	Yes
1900119453900	SERCO CONSTRUCTION GROUP, LTD	President/CEO / Serge Francois	DALLAS	cfrancois@sercoconstruction.com	214-948-0159	Serco Construction Group, Ltd. is a privately held DBE, MBE and HUB certified firm that offers a wide range of heavy civil construction projects in both the horizontal and structural concrete, and mass and structural excavation industries.	BL	M	No	Yes
1205217354400	SKE Construction, LLC	Shelly A. Eberhart	Cypress	shelly@ske1.net	281-585-4100	General contractor. Specializing in Design/build JOC. Experienced Utility Rehab/Install, Concrete replace, Fencing, Site Restoration	AI	F	No	Yes
1821441463500	SLR BUILDING CONTRACTORS, LLC	Stephanie L. Renteria	EDINBURG	S.RENTERIA@SLRBC.COM	956-383-8194	Commercial General Contractor, Roofing Contractor, Insulation Contractor, Damp Proofing Contractor	HI	F	Yes	Yes
1331034875300	SSP INDUSTRIES, LP	Melissa Miller	KILLEEN	mmiller@ssp-ind.com	254-699-2115	COMMERICAL PLUMBING, PIPELINE UTILITIES & ROAD BORING	WO	F	No	Yes
1721590394300	STATEWIDE SERVICES, INC.	Camell Alison Jr.	HOUSTON	mel@statewideservicesinc.net	713-864-3368	Land Clearing, Tree Removal Tree Trimming, Hauling, Debris, Concrete Contractor, Manhole Work and Excavation, Storm Sewer Installation, Sanitary Sewer Installation, & Waterline Installation, Supplier of Water Treatment Equipment	BL	M	No	Yes
1450571287800	SUPERIOR AUTOMATIC FIRE SYSTEM, LLC	DANIEL A HYTCHE	HOUSTON	superiorautomatic@gmail.com	713-413-9655	FIRE SPRINKLER INSTALLATION, SERVICE, INSPECTIONS	BL	M	No	Yes
1474762506000	SYNERGY MACHINE, LLC	OSCAR CRUZ	HOUSTON	OCRUZ@SYNERGYMACHINE.LLC.COM	832-641-3272	Manufacturing precision machined part such as foundation micro piles, helical Piles, turned products, fabricated pipe and welding equipment or tools. Structural steel casing. Service, asphalt and concrete repairs.	HI	M	No	Yes
1260331391200	Seneca Construction Management, LLC	GWENDOLYN MAUPIN	KILLEEN	gmaupin@seneca-construction.com	254-394-9303	I am a women owned and operated business. In June of this year I have successfully operated this construction company. I'm very proud of what I have built. It has not been easy to run a women ran company in this man dominated industry. I also have mostly	AI	F	No	Yes
1822774234500	South Texas Soil Services LLC.	Monica Lappe	Corpus Christi	monica@southtexasoilsservices.com	361-947-1120	Site work, commercial concrete	HI	F	No	Yes
1760356320000	Steven R. Hill Construction Co., Inc.	Steven Hill	Houston	Steven@SRHillConstruction.com	713-956-5861	CONCRETE SUBCONTRACTOR, EARTHWORK, DEMOLITION	HI	M	No	Yes
1270991760800	T & T EARTH MOVERS, INC.	Terry Suarez	SEMINOLE	phillip@earth-movers.net	432-955-0558	Specialize in oilfield heavy dirt construction. Services also include residential and business demolition, preparation of properties, asphalt paving, and underground utilities. Licensed for residential OSSF installation.	HI	M	Yes	Yes
1830413712000	T. F. Harper & Associates LP	Chrastecky Cindi	Buda	asmith@tfharper.com	512-440-0707	General Construction Contractor and Commercial Remodel. Playground Equipment Sales and Installation Company	WO	F	No	Yes
1921814372500	TEXAS PATRIOT CONTRACTING LLC	Nicholas Lesko	ROUND ROCK	txpatcont@gmail.com	737-226-8825	General Construction, sitework, demolition, concrete, carpentry, drywall, painting, landscaping services	DV	M	Yes	Yes
1760431719200	TGE RESOURCES, INC.	Robin Franks	HOUSTON	rfranks@tgeresources.com	713-744-5800	Environmental Consulting; Industrial Hygiene, Air Monitoring, Environmental Remediation & Construction, Asbestos Consulting, Molding Consulting, & Environmental Compliance & Permitting	WO	F	Yes	Yes
1815212973200	THAKKAR DEVELOPMENT COMPANY, LLC	Ravi Thakkar	HOUSTON	ravi@thakkarandcompany.com	281-318-1515	Residential and commercial construction and real estate development	AS	F	No	Yes
1203114535700	THE SABINAL GROUP, L.L.C.	Daniel Benavidez	San Antonio	danny@sabinal-group.com	210-226-3400	Construction	HI	M	No	Yes
1850688679700	THOMAS EXCAVATIONS AND UTILITIES LLC	Montez Kristopher Thomas	SAN ANTONIO	ThomasEXUTILLCC@gmail.com	210-993-7122	under ground utilities , sewer and drainage repair existing hydrant repair and installation and excavation (commercial)	BL	M	No	Yes
1208763967500	THR Enterprises, Inc.	Samuel Eaton	Houston	samuel.eaton@jngreenteam.com	832-279-9856	Construction Management, Waste Management Services, Business Consulting, and Property Management/Street Sweeping and Graffiti Removal	BL	M	No	Yes
1815458994100	TIA FACILITY SERVICES LLC	Lorenza Guerrero	EL PASO	lguerrero@tiallc.us	915-433-7881	General Construction, Janitorial Services, Grounds Maintenance	HI	F	Yes	Yes
1223866927400	TIERRA FIRME CONSTRUCTION, INC.	ADRIAN RUIZ	EL PASO	tierrafirmeco@aol.com	915-881-0200	STRUCTURAL CONCRETE AND SITE PREPARATION	HI	M	No	Yes
1455568297100	TITAN MILLING INC.	Sara Allen	JOHNSON CITY	sara@titanmillinginc.com	830-833-0474	Asphalt paving, seal coat, city street planning, utility excavation & installation, hard rock milling, retention ponds	AI	F	No	Yes
1270398323400	TOP GUN TOP DOG, INC.	Sec and VP Mark K Tafel	LEONARD	mark@topguntopdog.com	469-744-5900	Excavation, Land Clearing, Demolition, Disaster Recovery and site preparation.	WO	F	Yes	Yes
1842737421200	TREG EROSION CONTROL SPECIALISTS, LLC	Tiffany Rawls	FORT WORTH	TregErosion@protonmail.com	817-592-6280	Earth Retention Contractor	WO	F	No	Yes
1760775331000	TRINI CONSTRUCTION BUILDER LLC	Reginald Worlds	AUSTIN	INFO@TRINICONSTRUCTIONBUILDER.COM	512-506-1310	Subcontracting & General Construction opportunities	BL	M	No	Yes
1522374490300	Tec Excavation, Inc.	President - Twyla K Clutter	MIDLAND	tkc@teexcavation.com	432-687-5346	MINOR STRUCTURES; UNDERGROUND AND UTILITY WORK 14302\$	WO	F	No	Yes
1455366440100	TexasChile Inc	Pia Van Ryder	KINGWOOD	info@txchile.com	713-397-0230	Commercial Construction; Parking Lots, Driveways, Underground Pipes (Utilities), Sidewalks, and Demolition Services/Storm Sewer, Waterline, Sanitary L	HI	M	No	Yes
1751832175100	Thedford Construction Company Inc	Wilma Thedford	TYLER	thedford_const@tyler.net	903-561-1584	Underground and overhead electrical contractor for local electric delivery companies. Also work for large companies that have their own primary meteri	WO	F	No	Yes
1462540571800	UMD ENERGY SOLUTIONS	Mia Ngo	HOUSTON	payroll@umdenergysolutions.com	281-895-3210	Construction concrete, building, commercial remodel, Services in Talent and Acquisitions, IT related services (Infrastructure, Platform, Cloud),	AS	M	No	Yes
1711048626700	USA AMTECH INC	Mohsin Ulhaque	THE WOODLANDS	mohsin@usamtech.com	832-837-9801	Sidewalk, Driveway Repair Contractor, Concrete Repair Contractor, Canal Construction Contractor, Underground Utilities Contractor, Paver & Bricks	AS	M	Yes	Yes
1364777495200	Underground Water Solutions Company, Inc	Zoila Benitez	Elgin	zoila@uwsc.net	512-278-9333	Water and Sewer Line and Related Structures Construction	HI	F	No	Yes

1753044081100	V & V SERVICES, INC.	Linda Darden Verhovshek	CARROLLTON	VANDVENTERPRISES@TX.RR.COM	972-492-7613	Environmental Support Services - Erosion Control Services - Storm Water Management Services - Contract Management Services - Purchasing Agent Materials Supplier - Project Management/Scheduling/Logistics - Transportation Battery Supplier	BL	F	No	Yes
1841875969400	VOSBURG WELSH LLC	Operations Manager / Matthew James Welsh	FAIRVIEW	matthew.welsh@vosburgwelsh.com	972-430-8421	Our company provides private utility location and Subsurface Utility Engineering (SUE) services. utility coordination, ground penetrating radar, concrete scanning.	DV	M	Yes	Yes
1833561541700	Vantage Point Contractors	JACK YARBROUGH	LUMBERTON	tish@vantagepointcontractors.com	409-209-5222	We are demolition and excavation contractors that offer demolition, mowing, land clearing, site prep, foundation pads, ponds, driveways and more.	WO	F	No	Yes
1203879401700	Vertex Contractors, LLC	Erika R Ruiz	EL PASO	erruiz@vertexcontractors.net	915-591-6170	Heavy construction other than building construction and a special kind of trade construction. Selective demolition, earthwork, storm drain, underground utilities, site concrete and building concrete.	HI	F	No	Yes
1742955455700	Villaverde, Inc.	RAMON VILLAVERDE	EL PASO	ramon@villaverdeinc.com	915-351-8822	CONSULTING CIVIL ENGINEERING	HI	M	No	Yes
1760541820500	W. A. Robbins Construction Co., Inc.	Wendell A. Robbins III	Houston	wendell3@warobbinsconstruction.com	713-644-5823	Interior & Exterior Renovations, Concrete Construction, and Underground Utilities (cabling & fiber optics)	BL	M	No	Yes
1522408948000	WELCH EXCAVATION & UTILITY COMPANY, INC.	President - Janis Lee Welch	WINONA	welchexcavation@gmail.com	903-877-3528	COMMERCIAL SITEWORK, DEMOLITION, PAVING AND UTILITY WORKT	WO	F	Yes	Yes
1810967715500	WESSON CONSTRUCTION SERVICES LLC	Roylins Wesson	GRAND PRAIRIE	rwesson@wessoncs.com	469-556-2580	General Contracting firm that provides Construction Project Management, budgeting, Scheduling, and consulting	BL	M	No	Yes
1752035030100	WILLIAMS PAVING AND EXCAVATION, INC.	ROBERT Williams,SR	ODESSA	dward@willpave.com	432-332-8901	ASPHALT PAVING, SITE WORK & HAULING SERVICES 02680\$	BL	M	No	Yes
1851782407600	WTX CONSTRUCTION LLC		El Paso	wtxconstruction_llc@yahoo.com	915-218-9869	Rockwalls, retaining walls, landscaping, groundskeeping, excavation & grading.	HI	M	No	Yes
1451183838600	YARROW LANDSCAPING AND LAWN CARE LLC	Staci Duhan	AUSTIN	STACI@YARROWLANDSCAPING.COM	512-694-7392	We are a HUB-certified landscape design and install company in Austin since 2011. We do everything in-house including Xeriscaping, Hardscapes, Welded Walls, Native and Adaptive Plants, Irrigation, Masonry	WO	F	Yes	Yes
1454044771200	YUCCA CONTRACTING	Maggie Vaquera	EL PASO	israel@yuccaconstruction.com	915-525-7135	Painting, insulation, plumbing, electrical, demolitions, flooring, roofing, suspending ceilings, door/window frames all types,concrete slabs, sidewalks,footings asphalt excavation, field and shop welding, field and shop steel fabrication	HI	M	Yes	Yes
1462877421900	Yoko Excavating, LLC	Javier Alonzo	Belton	yokoexcavatingllc@gmail.com	254-780-9707	Dirt and concrete excavation for mainly commercial properties	HI	M	No	Yes
1831791482000	ZAMCO DIRECTIONAL DRILLING LLC	Josue zamarron Josue zamarron	HOUSTON	josue@zam-construction.com	832-306-0400	Underground utilities Storm Sewer Duct bank	HI	M	No	Yes
1571241153500	ZTEX CONSTRUCTION, INC.	Joaquin Royo	EL PASO	AR@ZTEXCONSTRUCTION.COM	915-591-6900	Earthwork;Paving; Utility line construction, Water & Sewer line related structure and construction, Highway, Street, and Industrial building constructionn, Concrete	HI	M	No	Yes
1262647044200	ZTF GROUP, LLC	Faith Twardowski	MALAKOFF	ztfgroupx@gmail.com	903-489-7052	Our team of Professionals offer Industrial/Commercial Full-Service Company, Power Generation, Install Turnkey, Preventative Maintenance, Power, Electrical, Plumbing, Heating, Air Conditioning, Other Building Equipment	AS	F	Yes	Yes

Date : 2024/01/18 09:41:13

CMBL SUMMARY

Search Found 265 Vendors ,265 are Hubs , Includes 0 Inactive Vendors

Search Condition : SearchType=HUB's Only,Section1 Class Code=912,Section1 Item(s)=(44)

Results for HUBs for 913-48 : Construction, Special Foundation										
Vendor ID	Company Name	Contact Person	City	Email	Phone	Business Description	HUB Eligibility	HUB Gender	CMBL Stat	HUB Status
1475357271900	1DZ ENTERPRISE LLC	Debra A. Garcia	ARANSAS PASS	debbiegarc20@gmail.com	361-534-4244	Janitorial Service, Construction Cleanup, Site Preparation, Demolition, Demolition Cleanup,Paving, General Construction, Concrete Work	HI	F	No	Yes
1872687474800	ALAS LLC	Raul Alatorre	DEL RIO	alas.llc@yahoo.com	830-765-7285	General Contracting, Maintenance Commercial/Residential, New Construction, General Services	HI	M	Yes	Yes
1461387592200	ARS SPECIALTY CONTRACTORS, LLC	Elizabeth Yetman Chavez	SAN ANTONIO	elizabeth@garrentx.com	210-736-4224	Our company provides high-quality construction services in the areas of general contracting, federal prime contracting as well as subcontracting in the areas of industrial coatings, large scale concrete construction, and gypsum underlayment and lightweight	HI	F	No	Yes
1542074052200	Armor Construction Co. Inc.	Hector LOYA	EL PASO	hector@armorconstruction.com	915-478-7744	GENERAL CONTRACTOR - REMODEL RESIDENTIAL & COMMERCIAL, FRAMING, DRYWALL, RENOVATIONS, ROOFING, ADDITIONS, PLUMBING, DEMOLITION, WELDING, CONCRETE, PAINTING, ETC.	HI	M	No	Yes
1465212948800	BLACK STALLION CONTRACTORS, INC.	Alejandra Macias	EL PASO	ksoto@blackstalliongroup.com	915-584-2098	General construction, specializing in concrete work, excavation, demolition, utilities, parks, swimming pools, water parks, roofing and design build	HI	M	No	Yes
1474499518500	CERVANTEZ CONSTRUCTION, LLC	Anacleto Cervantez	BRYAN	andy@cervantezconst.com	979-229-1590	earthwork, site work, excavation and grading, clearing, gravity storm and sanitary sewer, water pipe, asphalt paving, reinforced concrete paving, wet and dry bore	HI	M	No	Yes
1822756317000	COASTAL BEND ROOFING, LLC.	Matt Jensen	PEARLAND	info@cbrcs.com	281-407-0023	CBRCs is experienced in small and large scale renovations, additions, new construction, and demolition in both the public and private sectors. We provide disaster relief to include complete restoration, roofing, and property recovery.	WO	F	Yes	Yes
1852359466300	COLLABORATE CONSTRUCTION COMPANY, LLC	Deborah Campbell	MISSOURI CITY	cccofhouston@gmail.com	713-539-3522	Commercial construction, streets, buildings, bridges, concrete, marine construction, commercial diving.	HI	F	No	Yes
1861328327600	CONFORMANCE LLC	MIRZA FARJAD BAIG	RICHARDSON	Farjadbaig@gmail.com	214-430-8492	Engineering Consultant and Contractor	AS	F	No	Yes
1474614863500	CORZA CONSTRUCTION LLC	Juan Carlos Garza	AUSTIN	juancarlos@corzaconstruction.com	830-703-6846	Construction General Contractor; project management, concrete, masonry, landscaping, carpentry, rest areas, site prep & removal	HI	M	No	Yes
1453960586600	CUE CONSTRUCTION SERVICES, LLC	Clint Dillard	CYPRESS	cdillard@cueconstructionservices.com	832-495-8257	Concrete, site utilities, fire mains, water mains, earthwork, grading, sewers, stabilization via 3d model and GPS	WO	F	No	Yes
1460640097700	CWA FEDERAL CONSTRUCTION	Marcee Thomas	WACO	mthomas@cwaconstruction.com	254-772-9977	We provide design/build, construction management, and general construction services.	WO	F	No	Yes
1203000007400	Century Concrete Partners, Inc.	Candis Mixon	ALVIN	candis.ccp@gmail.com	832-993-4334	Century Concrete Partners specializes in foundation services, including,drill shaft foundations, foundation augmentation, helical anchors.	WO	F	Yes	Yes
1300889873900	Coastal Consulting, Inc.	Robbie Garcia	Corpus Christi	robbie@coastalconcretetx.com	361-739-1310	Concrete Services	HI	M	No	Yes
1742523918700	D & S S CONSTRUCTION, INC.	Pres./JANNA SCHURY	CORPUS CHRISTI	janna@dssconstruction.com	361-992-3566	GENERAL CONTRACTOR.	WO	F	No	Yes
1752888256000	D. Grimm, Inc.	Dawn Harvey	PLANTERSVILLE	dawn@dgrimminc.com	936-228-7802	Site preparation, earth work, foundation installation, erosion control, Right of Way Clearing and Maintenance, foundation installation, pad installation, clearing and grubbing	WO	F	No	Yes
1850633111700	DEVPRO COMMERCIAL CONTRACTORS, INC	JEFFREY DOBBINS	DALLAS	DEVPROTEX@SBCGLOBAL.NET	214-534-2789	Building construction.	BL	M	No	Yes
1464469415100	DYNAMIC BASE CONSTRUCTION, LLC	Lisa Thoma	BURLESON	l.thoma@tarkettsports.co	817-303-3484	Sports field and supportive athletic structures, natural grass, synthetic and artificial surfaces	HI	M	Yes	Yes
1922785859400	FITZ ASSOCIATES, LLC	Darla Lowden	HUMBLE	darla@fitzassoc.com	281-904-9280	Woman Owned, General Contractor, Engineering, Job Order Contracting, Design Build, ADA Compliance	WO	F	Yes	Yes
1834676727200	FULCRUM CONTRACTING GROUP LLC	ALEJANDRA JARAMILLO	EL PASO	projectmanager@fulcrumcontracting.net	915-892-9937	Concrete, Rockwall, Earthwork	HI	F	No	Yes
1270296441700	G2 CONTRACTORS, LLC	Heather McGlasson	Mason	heather@g2contractors.com	817-739-6560	General Contractor / Certified Construction Manager (CCM) who primarily works with land management and historical government agencies in all Regions within the State of Texas. Performs any type and size of project in Texas.	WO	F	Yes	Yes

1474561386000	GCI Solutions LLC	Casey Simien	HOUSTON	gdiaz@gci-solutions.net	832-777-3226	Business Management Consulting, Program Management/Project Management, & Compliance/Documentation Services, Construction Management and Logistics, Paving, Site Work, and Underground Trench	BL	F	No	Yes
1844863799300	GETAN RESOURCES, LLC	Jacques Burhama	HOUSTON	jburhama@getanresources.com	832-530-4518	Civil Engineering; CAD; Project & Construction Management; Construction Engineering & Inspection (CEI); Inspection & Forensics; Commissioning, Oversight & Compliance; Emergency Management Support Services (Planning-Response-Recovery)	BL	M	No	Yes
1853479887300	GRANCHELLI CIVIL CONSTRUCTION, LLC	James Granchelli	MCALLEN	jim@granchelliconstruction.com	956-928-1122	Heavy civil, earthwork, utilities, concrete structures, roads, streets, bridges	WO	F	Yes	Yes
1264438537400	GREENWORLD CONSTRUCTION	Michael Torres	AUSTIN	admin@gwmaterials.com	512-797-9876	Framing, Sheathing, Decking, Roofing, Exterior Siding, Insulation, Concrete Foundations, Drywall, Patios, Decks, Fences, multifamily, student housing, single family, industrial	HI	M	No	Yes
1383884246900	HEAVY ROADWAY CONSTRUCTION SERVICES, LLC	Mario Alcantara Cano	CEDAR PARK	mario@heavyroadway.com	512-567-8710	Firm provides highway construction services. Excavation and demolition services, and site clean-up.	HI	M	No	Yes
1384062327900	IBC CONSTRUCTION LLC	KHALID MAHMOOD	MURPHY	Callus247@gmail.com	469-662-5248	ROADS, BRIDGES, BUILDING, GAS STATION CONSTRUCTION, AND TOWN PLANNING	WO	F	Yes	Yes
1271010214100	INTEGRATED ENVIRONMENT LLC	Vanessa Jones	AUSTIN	jimmy@ieinc.us	512-450-3483	Building Construction, including General Contractors and Operative Builders	BL	M	Yes	Yes
1263988896000	J7 Services LLC	Tyler Groce	Caldwell	accounting@j7services.com	979-567-1951	Construction management, commercial and institutional building and Construction estimation services .	WO	F	Yes	Yes
1742527948000	JACQUEZ CONSTRUCTION AND TRUCKING LLC	Billy Jacquez	TOMBALL	billy.jac@outlook.com	832-526-8763	Construction Services, Concrete Structures, Dirt Work, Sand Blasting and Painting, Underground Utilities, Bulkheads, Boat Ramps, Pier Building, Tank Leak Repairs, Tank Building General Contracting	HI	M	Yes	Yes
1821331961100	JERSON'S CONCRETE LLC	Jerson's Concrete LLC	HOUSTON	jersonsconcrete@yahoo.com	832-873-9997	Ready Mix Delivery Services Build foundations, sidewalks, driveways, parking lots , etc	HI	F	Yes	Yes
1464597027900	JQC LLC	Hugo Jimenez	Friendswood	hugo@jqcconstruction.com	713-834-5324	Underground Utility, Concrete Paving	HI	M	No	Yes
1474934253200	LAUREL CONSTRUCTION, LLC	Samuel Laurel	CORPUS CHRISTI	laurelconstruction@aol.com	361-548-0604	Concrete paving, foundation, tilt wall, site prep, site clean up.	HI	M	No	Yes
1872550696000	LIT GLOBAL LOGISTICS LLC	Tiffanie Young	Dallas	tiffanie@litgloballogistics.com	214-868-3125		BL	F	No	Yes
1820775416100	LOYOLA CONSTRUCTION, LLC	Jessica Loyola	NEW BRAUNFELS	loyolaconstructionllc@gmail.com	830-743-5336	We offer all concrete related jobs weather it be New foundations, sidewalks, curbs , parking lots. We also do repairs to buildings like roof repairs, floors, walls etc.	HI	F	No	Yes
1852920026500	MAIDENHEAD CONSTRUCTION SERVICES INC.	Dustin Cox	HOUSTON	Dustin.cox@maidenhead.com	832-301-6499	Heavy civil and grading, civil structures and foundations including walls and supports. Specializing in maintenance shutdown and turnaround. Finish grading and road maintenance.	HI	M	No	Yes
1743003712100	MARS Industries, LLC	Alvino Rosales	Cedar Creek	arosales@marsindustries.us	512-629-1203	Water and waste water and pumping services.	HI	M	No	Yes
1832800982600	MAXIMUS CONSTRUCTION, LLC	Elizabeth Sturgill	CYPRESS	liz@maximustexas.com	832-557-7972	Our services include residential renovations, remodels, and new construction. We also conduct commercial construction services.	HI	F	Yes	Yes
1470957150000	Madero Engineers & Architects, LLC	Frank Madero	Houston	frank@madero.net	281-610-0367	Engineering Consulting; Program/Project/ Construction Mgmt; Rehab & Improvement of Infrastructures/Engineering Services, General Management Consulting Services & Project Management/Repair of Metal and Concrete Structures/Coating/ FRP Design Calculations	HI	M	No	Yes
1742522182100	NEW AGE GENERAL CONTRACTORS, INC.	Christopher Gonzalez	NEW BRAUNFELS	newagegcs@gmail.com	512-649-9530	Heavy Highway, Bridge General Contractors, Commercial and Institutional building, Construction management, Poured Concrete Foundation, Poured Concrete Structure Contractors, CMU Structure Contractors.	HI	M	Yes	Yes
1820633437900	NPPC CONSULTING LLC	Clinton Eastep	DALLAS	clint@nppc.biz	214-435-4194	Construction material wholesale, Medical and dental supply, computer related items wholesale, building and office supply wholesale, rebar supplier, pre-cast concrete supplier	AI	M	Yes	Yes
1262619989200	Next Generation Development, LLC	DANIEL OKORIE	Houston	info@goldsteinrec.com	832-380-4541	SINGLE FAMILY CONSTRUCTION & REMODELING, MULTI-FAMILY CONSTRUCTION & REMODELING, COMMERCIAL CONSTRUCTION & REMODELING	BL	M	No	Yes

1465498237100	Occupational Safety Solutions	Bradford Holman	Elgin	ossolutions@outlook.com	512-686-1381	OSS provides safety management consulting in the areas (1) OSHA 10/30 hour Training and safety awareness i.e. Flagger, CPR, Development of written safety programs, conducting site safety audits, air monitoring and sale of safety supplies.	BL	M	No	Yes
1821828379600	PHOENIX GENERAL CONTRACTORS, LLC	Peter Regalado	EL PASO	office@phoenix-gc.com	915-202-4415	Contractor, general contractor, flooring, concrete, painting, construction, remodel, additions, dry wall, foundations.	HI	M	Yes	Yes
1453833434400	R.T. CONSTRUCTION	Arnoldo Gomez	HUMBLE	gomezrtconstruction@gmail.com	713-298-2989	Commercial and Residential New Developments, Remodeling, Renovations, Sidewalks, Driveways, Roofing, Flooring, Walls, Painting, Bathrooms, Kitchens, Carpentry	BL	M	No	Yes
1262618473800	RAM CONCRETE & ASPHALT, LLC	Jose Meza	Lewisville	newservice@ram-ca.com	469-458-9700	Concrete & asphalt flat work, ada ramps, driveways, retaining walls, sidewalks, new paving and repairs	HI	M	Yes	Yes
1834189431100	RYMARH CORPORATION	Maria Hobbs	LEANDER	rymarhcorporation@gmail.com	512-986-9625	Construction General Contractor Construction Management	HI	F	Yes	Yes
1831424454400	S-CON CONSTRUCTION, LLC	Ashley Villalobos	CORPUS CHRISTI	ashley@s-conconstruction.com	361-299-5161	General Construction, site work, trenching, building renovations.	HI	M	No	Yes
1471399648700	SAW DIAMOND BLADES OF STEEL, LLC	Oshunti Foley	DESOTO	info@sdbofsteel.com	469-548-4184	Saw Diamond Blades of Steel, is a Concrete Cutting Construction Company based in the Dallas Fort Worth area. SDBS specializes in providing expert concrete cutting, core drilling, wall sawing and slab sawing, demolitions, masonry, asphalt and scanning.	BL	M	No	Yes
1205476566900	SPIRE CONSULTING GROUP, LLC	Anthony Gonzales	AUSTIN	proposals@spirecg.com	512-637-0845	Multi-disciplined construction engineering consulting firm.	HI	M	No	Yes
1412095040800	STRAIGHT LINE SAWING & SEALING, INC.	Eric Johnson	GRAND PRAIRIE	ejohnson@slsstexas.com	972-590-8922	pavement sawing and sealing, concrete construction, concrete repairs and maintenance	BL	M	No	Yes
1824979867100	TEXAS DEWATERING, LLC	Carl Fromen	HOUSTON	info@texasdewatering.com	936-246-3016	Repair and Rehabilitation of Bayous and Canals, Restoration of Dredging Placement Areas	HI	M	Yes	Yes
1921814372500	TEXAS PATRIOT CONTRACTING LLC	Nicholas Lesko	ROUND ROCK	txpatcont@gmail.com	737-226-8825	General Construction, sitework, demolition, concrete, carpentry, drywall, painting, landscaping services	DV	M	Yes	Yes
1870935880000	TexCon Utility, LLC	Benjamyn Tomerlin	FORT WORTH	info@TexCon-us.com	817-308-6464		DV	M	No	Yes
1455366440100	TexasChile Inc	Pia Van Ryder	KINGWOOD	info@txchile.com	713-397-0230	Commercial Construction; Parking Lots, Driveways, Underground Pipes (Utilities), Sidewalks, and Demolition Services/Storm Sewer, Waterline, Sanitary L	HI	M	No	Yes

Date : 2024/01/18 09:44:15

CMBL SUMMARY

Search Found 55 Vendors ,55 are Hubs , Includes 0 Inactive Vendors

Search Condition : SearchType=HUB's Only,Section1 Class Code=913,Section1 Item(s)=(48)